

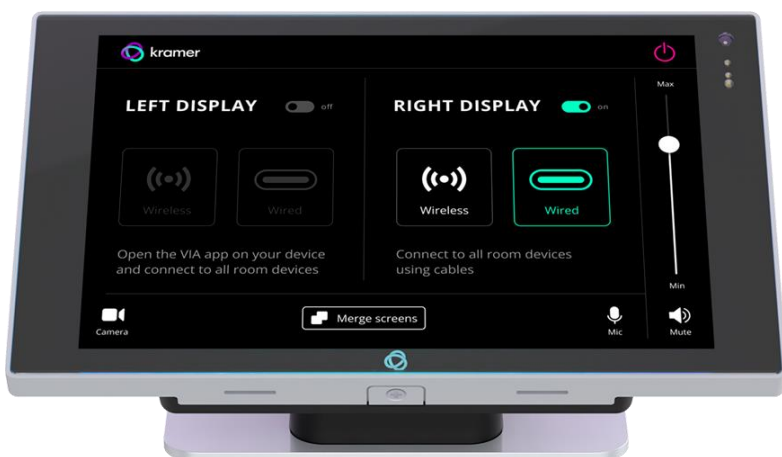

USER MANUAL

MODEL:

KT-2010 / KT-2010WM
10" Touch Panel



Contents

Contents	2
Introduction	3
Getting Started	3
Overview	4
Typical Applications	5
Defining KT-2010 / KT-2010WM 10" Touch Panel	6
KT-2010 Tabletop Mount	7
KT-2010WM On-Wall Mount	7
Mounting the KT-2010 / KT-2010WM	8
Mounting KT-2010 on a Table	8
Mounting KT-2010WM on a Wall	10
Connecting Options	12
Essential KT-2010 / KT-2010WM Settings	13
Controlling KT-2010 / KT-2010WM	14
Using Navigation Buttons or Gestures	14
Using the Home Page	15
Setting the Date and Time	15
Connecting to Wi-Fi or Ethernet	16
Installing an 802.1X Certificate	17
Changing the Automated Firmware Update	18
Changing the Automated Kramer Control update	20
Connecting the tablet to Kramer Control	21
Setting the Display and Keyboard Language	21
Scheduling a Daily Reboot	22
Password Protecting Device Settings	22
Factory Reset & Reboot	22
Logging Activity	23
Modifying Display Settings	23
Defining an auto-start playlist	24
Switching to Native Android Mode	25
Technical Specifications	26

Introduction

Welcome to Kramer Electronics! Since 1981, Kramer Electronics has been providing a world of unique, creative, and affordable solutions to the vast range of problems that confront the video, audio, presentation, and broadcasting professional on a daily basis. In recent years, we have redesigned and upgraded most of our line, making the best even better!

Getting Started

We recommend that you:

- Unpack the equipment carefully and save the original box and packaging materials for possible future shipment.
- Review the contents of this user manual.



Go to www.kramerav.com/downloads/KT-2010 / KT-2010WM to check for up-to-date user manuals, application programs, and to check if firmware upgrades are available (where appropriate).

Achieving Best Performance

- Use only good quality connection cables (we recommend Kramer high-performance, high-resolution cables) to avoid interference, deterioration in signal quality due to poor matching, and elevated noise levels (often associated with low quality cables).
- Do not secure the cables in tight bundles or roll the slack into tight coils.
- Avoid interference from neighboring electrical appliances that may adversely influence signal quality.
- Position your Kramer **KT-2010 / KT-2010WM** away from moisture, excessive sunlight and dust.

Safety Instructions



Caution:

- This equipment is to be used only inside a building. It may only be connected to other equipment that is installed inside a building.
- For products with relay terminals and GPIO ports, please refer to the permitted rating for an external connection, located next to the terminal or in the User Manual.
- There are no operator serviceable parts inside the unit.



Warning:

- Use only the power cord that is supplied with the unit.
- Disconnect the power and unplug the unit from the wall before installing.
- Do not open the unit. High voltages can cause electrical shock! Servicing by qualified personnel only.
- To ensure continuous risk protection, replace fuses only according to the rating specified on the product label which is located on the bottom of the unit.

Recycling Kramer Products

The Waste Electrical and Electronic Equipment (WEEE) Directive 2002/96/EC aims to reduce the amount of WEEE sent for disposal to landfill or incineration by requiring it to be collected and recycled. To comply with the WEEE Directive, Kramer Electronics has made arrangements with the European Advanced Recycling Network (EARN) and will cover any costs of treatment, recycling and recovery of waste Kramer Electronics branded equipment on arrival at the EARN facility. For details of Kramer's recycling arrangements in your particular country go to our recycling pages at www.kramerav.com/il/quality/environment.

Overview

Congratulations on purchasing your **Kramer KT-2010 / KT-2010WM 10" Touch Panel**.

KT-2010 / KT-2010WM is a new powerful, 10-inch, IPS, multi-touch, touch panel with 1920x1200 resolution. Elegantly designed for decorative room integration, this portable touch panel can be deployed either on a tabletop or wall.

KT-2010 / KT-2010WM, with the latest Android 11, supports wired PoE (Power over Ethernet) and advanced Wi-Fi connectivity options. The touch panel has a built-in speaker and camera and comes either with a tabletop or a wall mount. The touch panel is easy to assemble, using elegant wiring, secured mounting, reliable operation and flexible deployment.

KT-2010 / KT-2010WM is a touch panel that is ideal for any 24/7 Kramer-supported commercial AV or control application and features a user-friendly, fully customizable graphical user interface configured by Kramer software.

Exceptional Quality

- **Elegant Design** – Smooth integration with room furniture, either on tables or walls, with flexible panel cabling and locking design options.
- **Superior User Experience** – IPS 1920x1200 hi-resolution screen with $\pm 80^\circ$ horizontal and vertical wide viewing angles, built-in lighting sensor for auto-adaptable brightness, and advanced 10 multi-touch points and 2-finger gesture capabilities.
- **Powerful Processing** – i.MX8M Plus Quad Core A53, 4GB RAM, 32GB ROM processing performance, smoothly running complicated media and graphics-rich applications, such as H.265 video, audio streams encoding and decoding, and seamless hi-resolution 5Mp FF camera operation.
- **Flexible Services** – Latest Android 11 operating system. Advanced and User-friendly Operation
- **Easy Installation** – Powering and connectivity via a single Ethernet cable.
- **Flexible Mounting** – Including table and wall mounts.
- **Optional Connectivity** – Simple wireless Bluetooth 5 as well as connection to USB peripheral devices for either table or wall-mount installations, using the included USB cable.
- **Reliable Networking** – Seamless switching between wired and wireless 802.11ac connectivity.

- Versatile Powering Options – PoE and power adapter (sold separately).
- Auto Sensing – Optimized performance and operation according to automatically detected LAN speed.
- Firmware Upgrade – Define automatic updates on a predefined time of the day or update manually using USB port.

Security

- Secured Operation – Highly secured operation of applications using password protection, hidden control buttons and more. Red LED alert when camera is active.
- Secured Deployment – Flexible locking options to prevent unwanted panel-mount removal, elegantly designed to remain out of site.

Typical Applications

The KT-2010 / KT-2010WM is ideal for the following typical applications:

- Control user interface in meeting and conference rooms, boardrooms, and auditoriums.
- Presentation of room scheduling.

Defining KT-2010 / KT-2010WM 10" Touch Panel

This section defines KT-2010 / KT-2010WM.

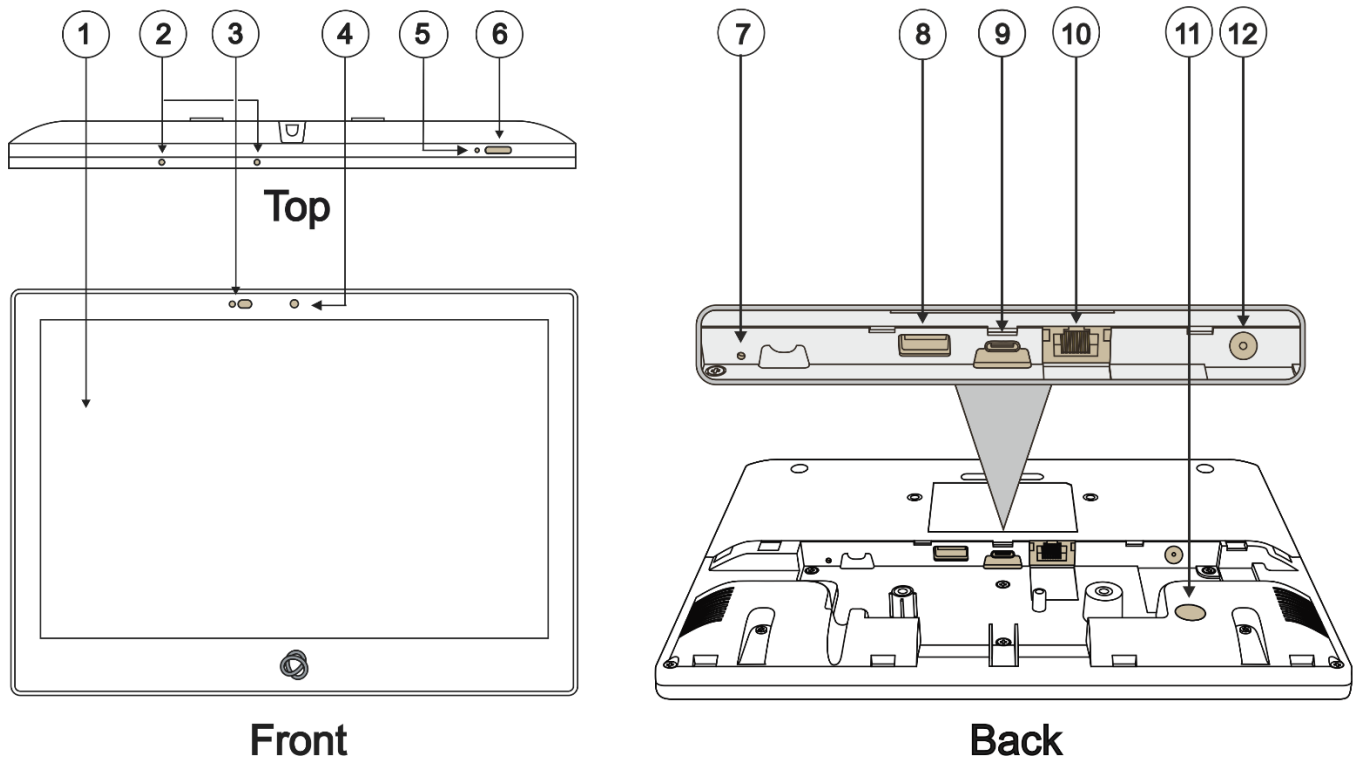

Figure 1: KT-2010 / KT-2010WM 10" Touch Panel

#	Feature	Function
①	Display	Touch panel
②	Microphone	For audio communication, recording or conferencing.
③	Proximity Sensor	Automatically adjusts the screen brightness and camera according to the room lighting conditions.
④	Camera	For remote room viewing or video conferencing.
⑤	Reset	Located on the topside. Insert a pin and hold for a few seconds to restart.
⑥	Home Button	Press to wake up / darken the screen.
⑦	Restore Factory Reset Button	Insert a pin and hold for 22 seconds to reset the device to factory default values.
⑧	USB 3.0 Port	Multipurpose port for external connection.
⑨	USB Type-C Port	Multipurpose port for external connection.
⑩	LAN 1G(PoE) RJ-45 Port	Connect to the LAN for network communication. KT-2010 and KT-2010 / KT-2010WM are powered by PoE (power over ethernet) delivered through the LAN port. Optionally, you can connect the power adapter too (as backup).
⑪	Kensington Lock	Anti-theft security slot for locking the device.
⑫	12V/2A DC Connector	Connect to the power adapter (optional, purchased separately).

KT-2010 Tabletop Mount

This section defines the KT-2010 / KT-2010WM tabletop mount.

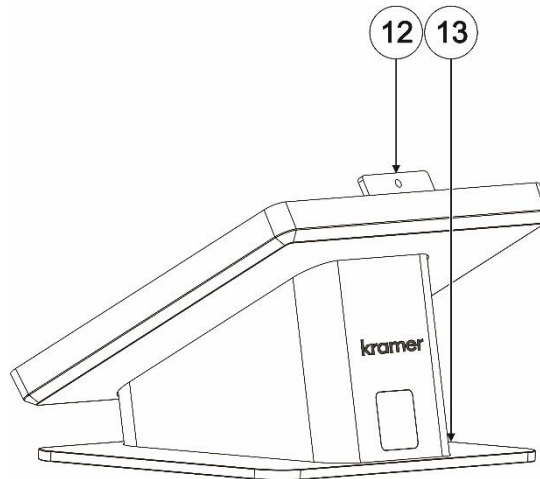

Figure 2: Tabletop Mount Rear View

#	Feature	Function
12	Screw Opening	For securing the 10" Touch Panel to the tabletop mount using the supplied M3 screw.
13	2 x 5/32" Screw Opening	Optional: For safely securing the tabletop mount to the table from underneath.

KT-2010WM On-Wall Mount

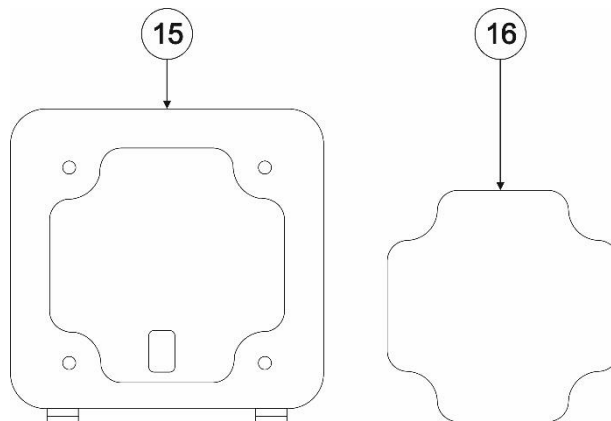



Figure 3: On Wall Mount

#	Feature	Function
15	Wall mount bracket	For securing the 10" Touch Panel to the wall mount bracket using the supplied M3 screw. For measurements see the image in Mounting KT-2010WM on a Wall on page 10.
16	Double-sided tape	For securing the wall mount bracket to the wall

Mounting the KT-2010 / KT-2010WM

The **KT-2010** package is for mounting the tablet on a table and the **KT-2010WM** package is for mounting the tablet on a wall.

 Always be careful when attaching or removing the 10" Touch Panel from a mount.

Mounting KT-2010 on a Table

Mount **KT-2010** on a table using one of the following options:

- **Moveable Mount:** Place the tabletop mount on the table. Connected cables remain visible and the table remains intact.
- **Secure Mount:** Bolt the tabletop mount into the table. Connected cables are hidden through a hole in the table.

Moveable Mount

1. Remove the I/O cover:
 - Take out the 2 M2 screws.
 - Insert fingers into the two slots and slide the cover down.
2. Connect any necessary cables, running them through the table stand to the **KT-2010**.
3. Replace the I/O cover, taking care to prevent pressure on the RJ-45 cable:
 - Use a cable without a hood.
 - Curl the cable under the cover.
4. Close the cover with the 2 M2 screws.
5. Lay the **KT-2010** face-down and mount the table stand on it.
6. Insert and fasten the provided M3 screw that secures the bottom of the **KT-2010** to the table stand (see 12 in [KT-2010 Tabletop Mount](#) on page 7).

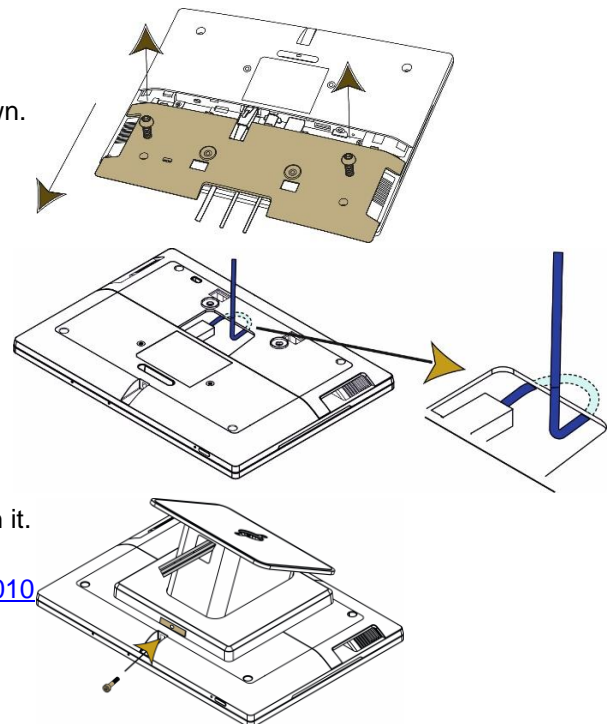

The table stand and tablet are now ready for use.

Secure Mount

If you want to pass cables from underneath, you may need to cut an opening in the table.

1. Remove the I/O cover:
 - Take out the 2 M2 screws.
 - Insert fingers into the two slots and slide the cover down.
2. Connect any necessary cables, running them through the table stand to the **KT-2010**.

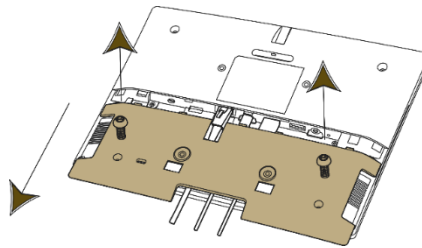

3. Replace the I/O cover, taking care to prevent pressure on the RJ45 cable:
 - Use a cable without a hood.
 - Curl the cable under the cover.
4. Close the cover with the 2 M2 screws.

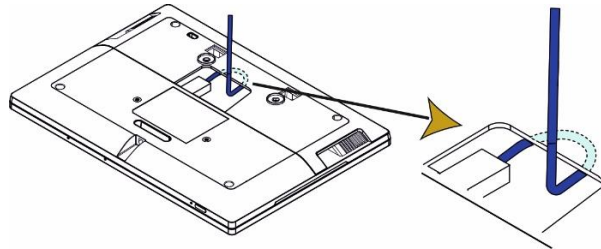

5. Lay the **KT-2010** face-down and mount the table stand on it.
6. Secure the stand to the table using the two provided 5/32" screws (see 13 in [KT-2010 Tabletop Mount](#) on page 7).

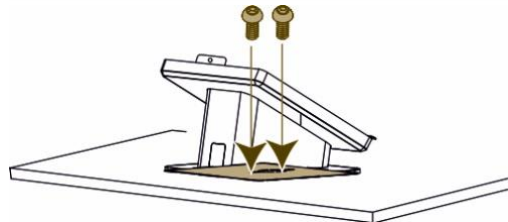

7. Mount the **KT-2010** on the stand and secure it with the provided M3 screw (see 12 in [KT-2010 Tabletop Mount](#) on page 7).

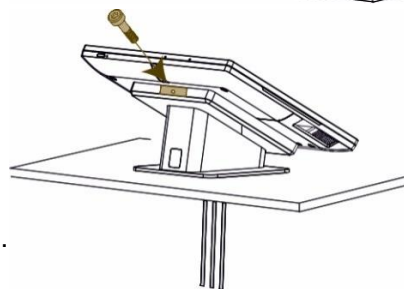

The table stand and tablet are now ready for use.

Mounting KT-2010WM on a Wall

Install **KT-2010WM** safely on a wall using a standard single Gang in-wall junction box. The cables are passed inside the wall and then connected to the rear side of the on-wall mount unit.

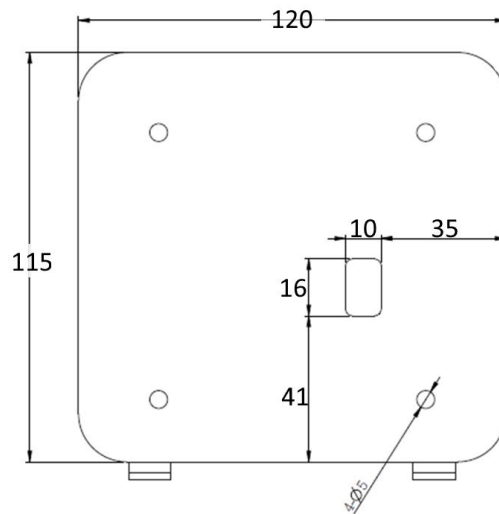
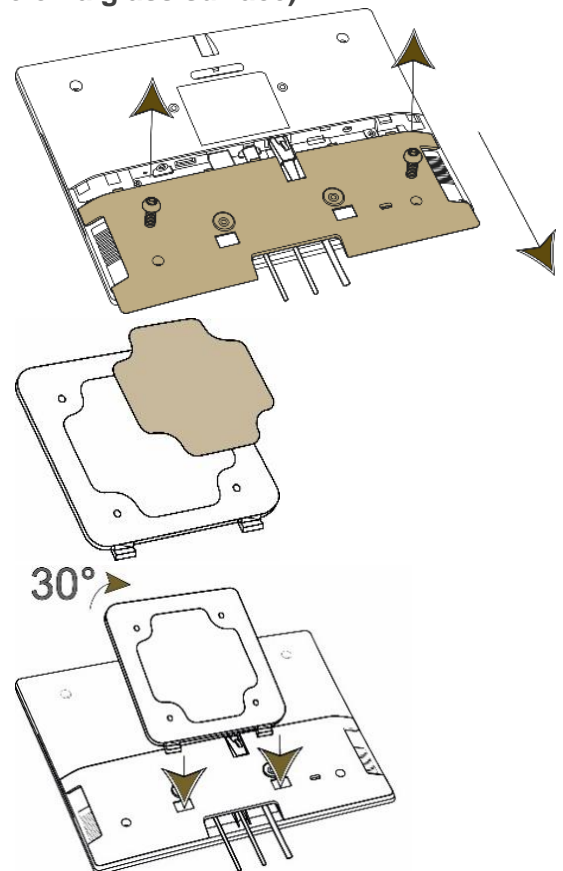

Figure 4: The on-wall mount's measurements

Inserting the On-Wall Mount Unit

To mount the device using double-sided tape (for example on a glass surface):

1. Remove the I/O cover:
 - Take out the 2 M2 screws.
 - Insert fingers into the two slots and slide the cover down.
2. Connect any necessary cables to the **KT-2010WM**.
3. Replace the I/O cover, and close with the 2 M2 screws.
4. Attach the double-sided tape to the back of the wall bracket (see 16 in [KT-2010WM On-Wall Mount](#) on page 7).
5. Click the wall bracket (see 15 in [KT-2010WM On-Wall Mount](#) on page 7) onto the back of the I/O cover (push the bracket into place while holding its top slightly outward).



6. Secure the wall bracket to the tablet cover using the M3 screw
7. Use the double-sided tape to fix the tablet on a wall.
The tablet is mounted.

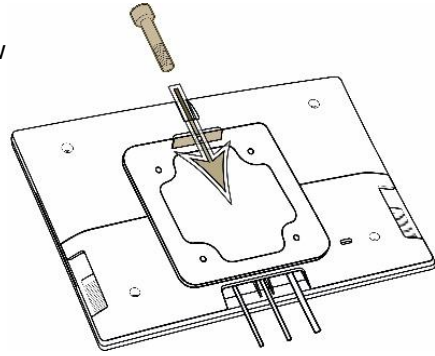

To mount the device on a secured wall bracket:

1. Mount the wall bracket (15 in [KT-2010WM On-Wall Mount](#) on page 7) on the installation point (screws not provided).

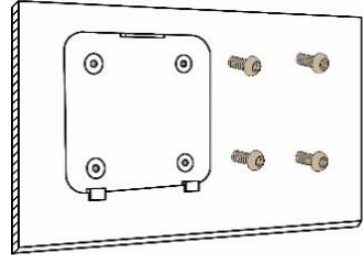

2. Connect the tablet to the wall bracket (lift it into place while holding the top of the tablet slightly outward).

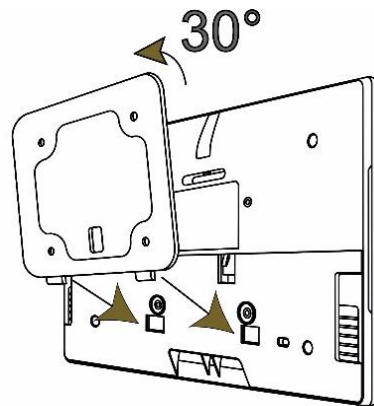

3. Use the provided M3 screw to secure the tablet to the wall bracket and back cover.

The tablet is mounted. ([Figure 5](#))

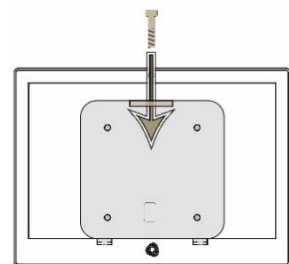

Connecting Options

You can power the KT-2010 or KT-2010WM using any or all of the following options:

1. Connect the PoE-enabled LAN RJ-45 connector to your local area PoE-enabled network.
2. Connect the power adapter to the 12V DC connector on the rear side. The DC power supply is optional: It can be purchased separately.

 When both PoE and the power supply are connected to the Touch Panel, the unit is powered by the power supply.

3. Use the internal battery (after initially charging the battery for 8 hours).

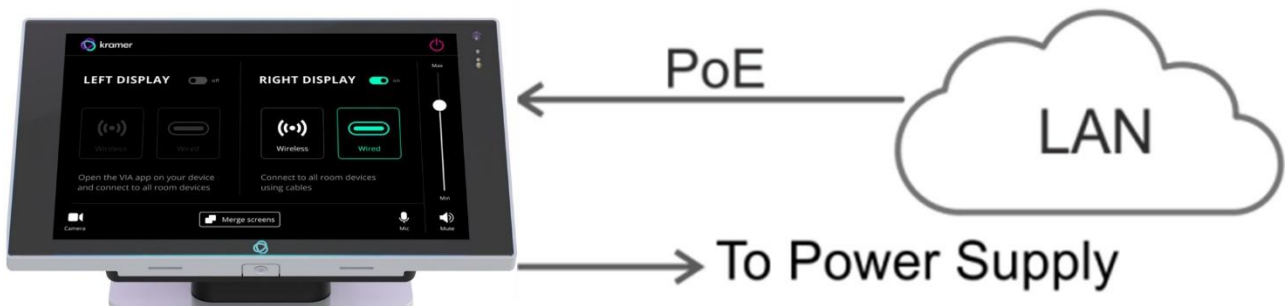

Figure 5: Powering the Touch Panel

Essential KT-2010 / KT-2010WM

Settings

The first time you use the tablet, examine the following settings:

1. **Set the device date and time;** [Setting the Date and Time](#) on page [15](#).
2. **Setup the Ethernet and/or Wi-Fi connections;** [Connecting to Wi-Fi or Ethernet](#) on page [16](#).
3. **Consider changing the time that the system checks for firmware (OS) updates;** [Changing the Automated Firmware Update](#) on page [18](#). By default this is set to midnight, change it if you have no internet access at this time or prefer another time.
4. **Consider changing the time that the system checks for Kramer Control (APK) updates;** [Changing the Automated Kramer Control update](#) on page [20](#). By default this is set to midnight, change if you have no internet access at this time or prefer another time.
5. **Setup the Kramer Control connection;** [Connecting the tablet to Kramer Control](#) on page [21](#).
6. **Change the display language** (if necessary); [Setting the Display and Keyboard Language](#) on page [21](#).

Controlling KT-2010 / KT-2010WM

Using Navigation Buttons or Gestures

By default, **KT-2010 / KT-2010WM** run the Kramer Control app and displays its login screen at start-up. Log into Kramer Control to access the customizable interface set-up defined by your IT department. You can also use the navigation buttons displayed at the bottom of the screen or setup your device to use apple-style gestures.

Using navigation buttons

Swipe a finger upwards from the line at the bottom of the screen and release to see the navigation buttons:

- ◀ - **Back** – Returns to the previous screen (or opens the home page if there is none).
- - **Home** – Opens the home page, see [Using the Home Page](#) on page [15](#).
- - **Recent apps** – Scroll between the active apps.

Changing the navigation system

By default, navigation buttons are used, however the tablet can be set to use Apple navigation gestures instead. To change the navigation method:

1. On the Home page, press **Settings** . The device's **Settings** menu opens.
2. Select **Advanced settings > System**.
3. In the System menu, press **Gestures** and then **System navigation**.
4. Select **Gesture navigation** or **3-button navigation**. If you are using Gesture navigation, the sensitivity is adjustable.

Using Gesture navigation

- **Back** – Drag a finger inwards from the left or right edge of the screen.
- **Home** – Swipe a finger upwards from the line at the bottom of the screen and release.
- **Recent apps** – Swipe a finger upwards from the line at the bottom of the screen and hold.

Hiding the Navigation Bar

To hide/unhide the navigation bar:

1. On the Home page, press the **Settings** button . The device's **Settings** menu opens.
2. In the Settings menu, open **Player settings** and enable **Fullscreen mode**.

Using the Home Page

Swipe a finger upwards from the line at the bottom of the screen and release to see the navigation buttons:

- - **Home** – Opens the home page.

To lock the Home page settings with a security password, see [Password Protecting Device Settings](#) on page [22](#).

The Home page contains the following icons:



- Chromium browser



- Tablet settings



- Kramer Control



- Kramer Control agent

Setting the Date and Time

The device arrives preset to New York time and you will need to set the correct time region.

To adjust the date and time settings:

1. On the Home page, press the **Settings** button . The device's **Settings** menu opens.
2. Select **Date & Time > Time zone**.
3. Set the correct **Region**. The time will display correctly.

Connecting to Wi-Fi or Ethernet

Connect an Ethernet cable to the device or activate Wi-Fi and setup a connection to your Wi-Fi. If multiple network connections are used, Ethernet will be prioritized over any others.

If you are using 802.1X authentication, do [Installing an 802.1X Certificate](#) on page [17](#), before you connect to the internet.

Connecting Ethernet

Ethernet connections must be plugged into the back of the device, see ⑧ in [Defining KT-2010 / KT-2010WM 10" Touch Panel](#) on page [6](#). By default, the IP address of the device is set automatically by a DHCP server.

Enabling 802.1X authentication

1. Do [Installing an 802.1X Certificate](#) on page [17](#).
2. From the Home page, open the **Settings** screen .
3. In the Settings screen, select **Network & Internet > Ethernet**.
4. Make sure the **Ethernet** is disabled and then enable **Security**.



802.1X authentication cannot be applied to active Ethernet connections

5. Select **802.1X settings** and input the **EAP** (Extensible Authentication Protocol) information.

Using a static IP address

1. From the Home page, open the **Settings** screen .
2. In the Settings screen, select **Network & Internet > Ethernet**.
3. Press **Ethernet IP mode** and select **Static**.
4. Enter the IP information and press **Connect**.

The static IP address is setup.

Connecting Wi-Fi

Enabling 802.1X authentication

1. Do [Installing an 802.1X Certificate](#) on page [17](#).
2. From the Home page, open the **Settings** screen .
3. In the Settings screen, select **Network & Internet > Wi-Fi**.
4. Make sure **Use Wi-Fi** is enabled. The device will scan and list the Wi-Fi networks.
5. Select a Wi-Fi SSID.
6. Check **Advanced options** and enter the Wi-Fi information in the fields that appear, then press **Connect**.
7. If you are using 802.1X authentication, then add the certificate information.

802.1X is enabled.

Installing an 802.1X Certificate

802.1X certificates enhance the security of network authentication. **KT-2010 / KT-2010WM** support .pem, .pfx and .p12 certificate formats.

Installing a certificate is a two-stage process: First import the certificate and then set it up.

Importing an 802.1X certificate

1. Copy the certificate file to an empty USB flash drive.
2. From the Home page, open the **Settings** screen .
3. Select **Advanced settings > Security > Encryption & credentials**.

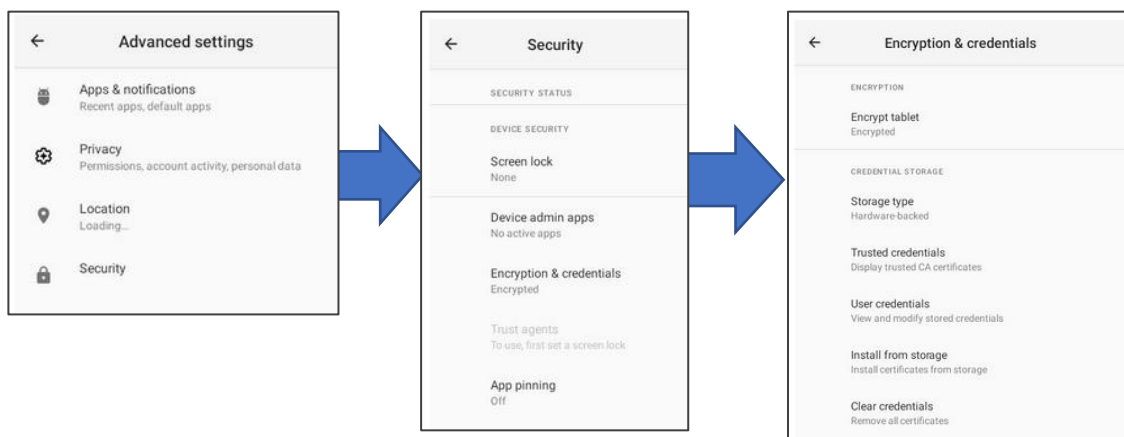



Figure 6: The path to Install from storage

4. In the Encryption & credentials screen, select **Install from storage**: The **Install a certificate** screen opens.
5. Select the **Wi-Fi certificate**: The **Recent** files screen opens.
To browse to the file location, press the 3 lines  at the top left of the screen.
6. Select the credentials file and install it, some certificates require you to know a password.

Setting up an 802.1X certificate

7. In the Settings screen, select **Network & Internet > Wi-Fi**.
8. Select **Install from storage**: The **Install a certificate** screen opens.
9. Select **Wi-Fi certificate** (also for Ethernet connections): The **Recent** files screen opens.
To browse to the file location, press the 3 lines  at the top left of the screen.

After installing the certificates, see [Connecting to Wi-Fi or Ethernet](#) on page [16](#) for instructions on using the certificates. Ethernet must be disabled before setting-up Ethernet certificates.

Changing the Automated Firmware Update

KT-2010 / KT-2010WM arrive preset to check for firmware (tablet OS) updates at midnight every day. If an update is found, the device will download the update file and install it. If you prefer to run manual updates, you must manually download the update file and then install it in the tablet.

Changing the time of the automated firmware check

1. From the Home page, open the **Settings** screen .
2. Select **Firmware update** and then select **Remote firmware upgrade URL**.

Remote firmware upgrade URL is the site from which the firmware is downloaded.

The upgrade URL (case sensitive): https://cdn.kramerav.com/web/apk/remote_app_update.xml

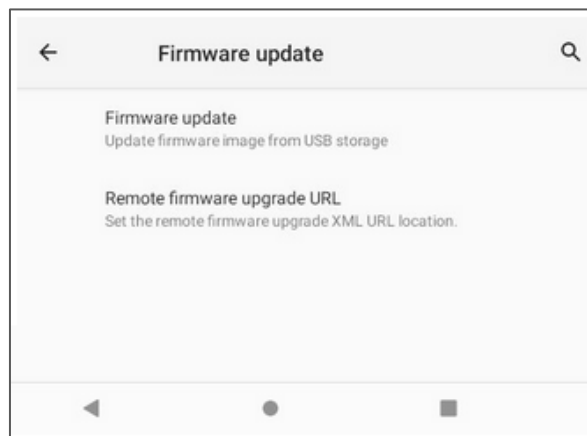

Figure 7: The Firmware update page

3. A pop-up opens, inviting you to set the check time:

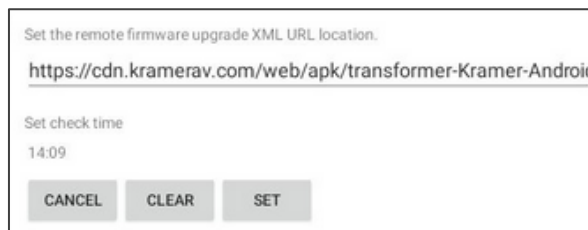

Figure 8: The Remote firmware upgrade URL page

4. To change the time that the system checks for updates, press **Set check time** and select a new time.
5. Press **OK** to close the window and then press **SET**.



Changing (or clearing) the URL will disable the updates.

Manually updating the firmware

Manual firmware updates require a downloaded firmware file from Kramer.

The firmware upgrade process requires:

- An empty USB flash drive to store the firmware file.
- A micro-USB OTG (on the go) cable to connect the USB flash drive to the tablet.
- Access to the back of the tablet.

You may need to remove the tablet from its mount for this purpose. The tablet should remain connected to a power source such as PoE or the optional power adapter (see ⑧ in [Defining KT-2010 / KT-2010WM 10" Touch Panel](#) on page 6).

To upgrade the firmware

1. Download the firmware update file from the Kramer website at https://www.kramerav.com/product/KT-2010#Tab_Resources.
 - Verify that you are using the correct **KT-2010 / KT-2010WM** firmware file as there maybe more than one firmware file available.
 - Do not unzip the firmware update file.
2. Copy the firmware file to an empty USB flash drive.
3. On the tablet, open the **Settings** screen .
4. Select **Firmware update** and then select **Firmware update** (again).
5. Plug the USB flash drive into a micro-USB OTG cable and connect the cable to the back of the tablet.
6. Click **START FIRMWARE UPDATE**.

The firmware update will then begin.

Changing the Automated Kramer Control update

KT-2010 / KT-2010WM arrive preset to check for Kramer APK (Android Application Package) updates at midnight every day. If an update is found, the device will download the update file and install it.

Changing the time of the automated APK update check

1. From the Home page, open the **Settings** screen .
2. Select **Remote APP upgrade URL**.

Remote APP upgrade URL is the site from which the APK is downloaded.

The upgrade URL (case sensitive) is:

<https://cdn.kramerav.com/web/apk/transformer-Kramer-AndroidR.xml>

3. A pop-up opens, inviting you to set the check time:

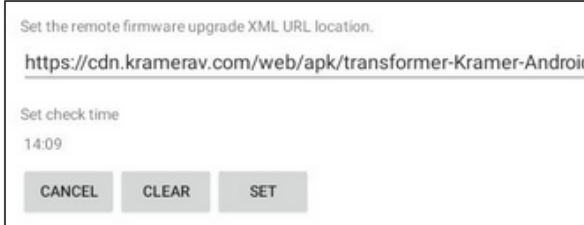

Figure 9: The Remote APP upgrade URL page



4. Press **Set check time** to select a new time.
5. Press **OK** to close the window and then press **SET**.



Changing (or clearing) the URL will disable the updates.

Connecting the tablet to Kramer Control



Kramer Control provides an interface which controls all aspects of the meeting space. For more information about [Kramer Control](#), see <https://www.kramerav.com/product/Kramer%20Control>.

KT-2010 / KT-2010WM come with two preinstalled apps: **Kramer Control** (icon ) and the **Kramer Control agent** (icon )

To use Kramer Control, a connection between the tablet and the Kramer Control server must be setup.

The **Kramer Control** connection can be configured either on the tablet itself, or by using a laptop connected to the same network as the tablet (see also <https://www.manula.com/manuals/kramer/kramer-control/1/en/topic/new-kramer-tablets>).

Setting the Kramer Control connection from the tablet

1. In the tablet's Home page, open the Chromium browser  and enter "<Kramer Control's IP>:8000" (without the quotation marks "").
2. Select the desired interface and copy its URL.
3. In the tablet's Home page, open the **Kramer Agent** app .
4. Press **Launch Control Interface** and paste the URL, then press OK.

Setting the Kramer Control link from a Windows laptop

The following is an alternative method to setting the Kramer Control link, which does not require use of the tablet (the tablet must be connected to the same network as the laptop).

Open a Chromium browser and enter:

`https://<IP of the tablet>:9804/launchurl?<IP of Kramer Control>:8000/?interface=&immersive=true`

Setting the Display and Keyboard Language

To set your preferred interface language:

1. From the Home page, open the **Settings** screen .
2. Select **Language & input**.
3. Press **Add a language** to select a language.
4. If you are using multiple languages, the order in which they are listed represents the priority assigned to them, change the order by dragging languages.
5. Press **On-screen keyboard** to select keyboard languages.

The keyboard language has been set.

Scheduling a Daily Reboot

A daily reboot is recommended to improve product performance and stability. The daily reboot option causes the device to reset itself every day and the set time (or within 30 minutes of the set time if it is in use).

1. From the Home page, open the **Settings** screen .
2. Select **Schedule Reboot** and set the reboot time.
3. Enable **Optimize Server Performance** to have the device reboot at a random time within 30 minutes of the scheduled time. If you are using multiple devices, then this prevents them from all rebooting at the same time.

The daily reboot is complete.

Password Protecting Device Settings

Device settings can be protected with a password to prevent users from making any changes.

1. From the Home page, open the **Settings** screen .
2. Select **Security Password** to enable and enter the password.

Factory Reset & Reboot

The **Settings > Reset** options menu enables you to perform a factory reset or to reboot the device, reset Wi-Fi or Bluetooth or reset app preferences.

To reset to factory settings

1. From the Home page, open the **Settings** screen .
2. Select **Erase all data (factory reset)**.

Other options available: Reboot device, Reset Wi-Fi, mobile & Bluetooth and Reset app preferences.

Resetting with the external reset button

Insert a pin into the pinhole on the back  (see [Defining KT-2010 / KT-2010WM 10" Touch Panel on page 6](#)) and hold for 22 seconds to reset the device to factory default values.

A second pinhole on the top,  can be used to restart the device by inserting a pin for a few seconds.

Logging Activity

By default, the device does not log activity. Logging can be useful for debugging or monitoring use.

Activating logging

1. From the Home page, open the **Settings** screen .
2. Select **Log** and set the **Log Location**.

Logging is activated.

Accessing an internally stored log file

A USB flash drive and OTG cable are required to copy an internally stored log file:

1. In the root directory of the flash drive, create a folder called “**_dump_debug_log**”.
2. Connect the OTG cable to the micro-USB connection on the back of the device.
3. Connect the flash drive to the OTG cable.
4. The device will automatically download the log file to the USB device and issue a confirmation message “**Saved log file to USB storage**”.

The log is accessed.

Modifying Display Settings

The screen orientation can be customized, and the navigation bar can be hidden.

Changing the screen orientation

1. From the Home page, open the **Settings** screen .
2. Select Display and then press Screen Orientation.

Choose between 0 degrees (default), 90 degrees, 180 degrees and 270 degrees.

Hiding the navigation bar

1. From the Home page, open the **Settings** screen .
2. In the Settings menu, open **Player settings** and enable **Fullscreen mode**.

The Navigation bar is no longer accessible.

Defining an auto-start playlist

The device can be set to automatically play the contents of a predefined folder. The folder can be internally defined or read from a flash device connected to the micro USB port or a Micro SD card inserted into the card reader (see [Defining KT-2010 / KT-2010WM 10" Touch Panel](#) on page 6).

To setup a playlist:

1. Load the media you want to play onto an SD card or USB flash drive. Play order is set by the alphabetic order of the item's names.
2. Connect the drive or card to the device (for a flash drive use an OTG cable connected to the USB port).
3. On the tablet, open the **Settings** screen .
4. Select Player Settings and then select Instant Play.
5. Enable **Instant play**. If you check **Copy and play as internal storage**, the device will load the (external) folder contents into internal storage.
6. Press SELECT FOLDER.
7. If you copied external content to internal storage, then you can remove the external device.

The Content field in the Home page will be changed to the storage location of your content.



The home page's Content field defines the auto-start link to Kramer Control.

Changing the value in this field is not recommended as it will disable Kramer Control.

Defining auto-start HTML or SMIL content

The device home page can be set to automatically run an HTML page or SMIL content.

1. Place your HTML content in a folder called HTML in the root of an SD card or flash drive and attach them to the device (for a flash drive use an OTG cable connected to the USB port).
2. When the USB drive is connected to the device, an automatic pop-up message will notify you that the copy is about to start.

The Content field in the Home page will be changed to the storage location of your content.



The home page's Content field defines the auto-start link to Kramer Control.

Changing the value in this field is not recommended as it will disable Kramer Control.

Switching to Native Android Mode

Switching to native Android mode turns the device into a regular android device, allowing you full control of its content.



Changing to native Android will disable Kramer Control.

To make the switch:

1. From the Home page, open the **Settings** screen .
2. Select Player Settings and then press Native Android Mode.



Figure 10: The Player settings page

Native Android mode is restored.

Technical Specifications

Ports	1 USB Type C	On a female (ADB) connector
	1 USB Type A	On a female connector
	1 Ethernet	On an RJ-45 female connector, 10/100/1000M with PoE 802.3at
Platform	Operating System	Android Version 11
	CPU	ARM Quad Core Cortex-A53 up to 1.8Ghz (64 bit)
Memory	RAM	LPDDR4 4GB
	Internal	32GB eMMC (flash)
Display	Touch Panel Type	10.1 point capacitive multi-touch
	Size	10.1"
	Resolution	1920x1200 RGB pixels, 16:9 aspect ratio, 350cd/m2 brightness, 1000:1 contrast ratio
Wireless Connectivity	Wi-Fi	Wi-Fi 6, 802.11 a/b/g/n/ax
	Bluetooth	BT 5.0
Video	Camera	1x 5MP FF
	Video Formats	H.264, H.265, VC-1, MPEG-4, VP8, VP9
	Image Codecs	JPEG, BMP, GIF, PNG
	VESA	Metal-fittings mounting screw holes for 75x75mm VESA mount
Audio	Speakers	2 built-in x 1W
	Codecs	MPEG, OGG, AAC
	Microphone	2 built-in
Power	PoE	44 to 57VDC 0.3A complies with IEEE802.3af and IEEE802.3at PoE standards
	Optional power adapter	12V 2A
Controls	Function button	On top
	Reset button	On top, recessed
	Factory reset button	On back, recessed
LED	Side-light	Can indicate room status (requires 3 rd party integration)
Environmental conditions	Operating temperature	0~40°C (32~104°F)
	Storage temperature	-20~60°C (-4° to 140°F)
	Operating Humidity	5% to 85%
	Storage Humidity	5% to 90%
Regulatory Compliance	Safety	CE, FCC, UL, UKCA
	Environmental	RoHs, WEEE
Dimensions	Tablet (W, D, H)	242 x 185 x 173mm
	Tabletop stand	131 x 111 x 98mm (KT-2010 only)
	Wall mount	120 x 115 x 11mm (KT-2010WM only) See the image in Mounting KT-2010WM on a Wall on page 10 .
Weight	Tablet	482g
	Tabletop stand	300g
Shipping carton (4 pcs)	Dimensions (W, D, H)	309 x 242 x 175mm
	Weight	KT-2010: 1.4kg (approximate) KT-2010WM: 1.2kg (approximate)
Accessories	Optional	Power adapter.
	KT-2010	Table-top mount and screws.
	KT-2010WM	On-wall mount bracket and screws.
Specifications are subject to change without notice at www.kramerav.com		

The warranty obligations of Kramer Electronics Inc. ("Kramer Electronics") for this product are limited to the terms set forth below:

What is Covered

This limited warranty covers defects in materials and workmanship in this product.

What is Not Covered

This limited warranty does not cover any damage, deterioration or malfunction resulting from any alteration, modification, improper or unreasonable use or maintenance, misuse, abuse, accident, neglect, exposure to excess moisture, fire, improper packing and shipping (such claims must be presented to the carrier), lightning, power surges, or other acts of nature. This limited warranty does not cover any damage, deterioration or malfunction resulting from the installation or removal of this product from any installation, any unauthorized tampering with this product, any repairs attempted by anyone unauthorized by Kramer Electronics to make such repairs, or any other cause which does not relate directly to a defect in materials and/or workmanship of this product. This limited warranty does not cover cartons, equipment enclosures, cables or accessories used in conjunction with this product.

Without limiting any other exclusion herein, Kramer Electronics does not warrant that the product covered hereby, including, without limitation, the technology and/or integrated circuit(s) included in the product, will not become obsolete or that such items are or will remain compatible with any other product or technology with which the product may be used.

How Long this Coverage Lasts

The standard limited warranty for Kramer products is seven (7) years from the date of original purchase, with the following exceptions:

1. All Kramer VIA hardware products are covered by a standard three (3) year warranty for the VIA hardware and a standard three (3) year warranty for firmware and software updates; all Kramer VIA accessories, adapters, tags, and dongles are covered by a standard one (1) year warranty.
2. Kramer fiber optic cables, adapter-size fiber optic extenders, pluggable optical modules, active cables, cable retractors, ring mounted adapters, portable power chargers, Kramer speakers, and Kramer touch panels are covered by a standard one (1) year warranty. Kramer 7-inch touch panels purchased on or after April 1st, 2020 are covered by a standard two (2) year warranty.
3. All Kramer Calibre products, all Kramer Minicom digital signage products, all HighSecLabs products, all streaming, and all wireless products are covered by a standard three (3) year warranty.
4. All Sierra Video MultiViewers are covered by a standard five (5) year warranty.
5. Sierra switchers & control panels are covered by a standard seven (7) year warranty (excluding power supplies and fans that are covered for three (3) years).
6. K-Touch software is covered by a standard one (1) year warranty for software updates.
7. All Kramer passive cables are covered by a lifetime warranty.

Who is Covered

Only the original purchaser of this product is covered under this limited warranty. This limited warranty is not transferable to subsequent purchasers or owners of this product.

What Kramer Electronics Will Do

Kramer Electronics will, at its sole option, provide one of the following three remedies to whatever extent it shall deem necessary to satisfy a proper claim under this limited warranty:

1. Elect to repair or facilitate the repair of any defective parts within a reasonable period of time, free of any charge for the necessary parts and labor to complete the repair and restore this product to its proper operating condition. Kramer Electronics will also pay the shipping costs necessary to return this product once the repair is complete.
2. Replace this product with a direct replacement or with a similar product deemed by Kramer Electronics to perform substantially the same function as the original product. If a direct or similar replacement product is supplied, the original product's end warranty date remains unchanged and is transferred to the replacement product.
3. Issue a refund of the original purchase price less depreciation to be determined based on the age of the product at the time remedy is sought under this limited warranty.

What Kramer Electronics Will Not Do Under This Limited Warranty

If this product is returned to Kramer Electronics or the authorized dealer from which it was purchased or any other party authorized to repair Kramer Electronics products, this product must be insured during shipment, with the insurance and shipping charges prepaid by you. If this product is returned uninsured, you assume all risks of loss or damage during shipment. Kramer Electronics will not be responsible for any costs related to the removal or re-installation of this product from or into any installation. Kramer Electronics will not be responsible for any costs related to any setting up this product, any adjustment of user controls or any programming required for a specific installation of this product.

How to Obtain a Remedy Under This Limited Warranty

To obtain a remedy under this limited warranty, you must contact either the authorized Kramer Electronics reseller from whom you purchased this product or the Kramer Electronics office nearest you. For a list of authorized Kramer Electronics resellers and/or Kramer Electronics authorized service providers, visit our web site at www.kramerav.com or contact the Kramer Electronics office nearest you.

In order to pursue any remedy under this limited warranty, you must possess an original, dated receipt as proof of purchase from an authorized Kramer Electronics reseller. If this product is returned under this limited warranty, a return authorization number, obtained from Kramer Electronics, will be required (RMA number). You may also be directed to an authorized reseller or a person authorized by Kramer Electronics to repair the product.

If it is decided that this product should be returned directly to Kramer Electronics, this product should be properly packed, preferably in the original carton, for shipping. Cartons not bearing a return authorization number will be refused.

Limitation of Liability

THE MAXIMUM LIABILITY OF KRAMER ELECTRONICS UNDER THIS LIMITED WARRANTY SHALL NOT EXCEED THE ACTUAL PURCHASE PRICE PAID FOR THE PRODUCT. TO THE MAXIMUM EXTENT PERMITTED BY LAW, KRAMER ELECTRONICS IS NOT RESPONSIBLE FOR DIRECT, SPECIAL, INCIDENTAL OR CONSEQUENTIAL DAMAGES RESULTING FROM ANY BREACH OF WARRANTY OR CONDITION, OR UNDER ANY OTHER LEGAL THEORY. Some countries, districts or states do not allow the exclusion or limitation of relief, special, incidental, consequential or indirect damages, or the limitation of liability to specified amounts, so the above limitations or exclusions may not apply to you.

Exclusive Remedy

TO THE MAXIMUM EXTENT PERMITTED BY LAW, THIS LIMITED WARRANTY AND THE REMEDIES SET FORTH ABOVE ARE EXCLUSIVE AND IN LIEU OF ALL OTHER WARRANTIES, REMEDIES AND CONDITIONS, WHETHER ORAL OR WRITTEN, EXPRESS OR IMPLIED. TO THE MAXIMUM EXTENT PERMITTED BY LAW, KRAMER ELECTRONICS SPECIFICALLY DISCLAIMS ANY AND ALL IMPLIED WARRANTIES, INCLUDING, WITHOUT LIMITATION, WARRANTIES OF MERCHANTABILITY AND FITNESS FOR A PARTICULAR PURPOSE. IF KRAMER ELECTRONICS CANNOT LAWFULLY DISCLAIM OR EXCLUDE IMPLIED WARRANTIES UNDER APPLICABLE LAW, THEN ALL IMPLIED WARRANTIES COVERING THIS PRODUCT, INCLUDING WARRANTIES OF MERCHANTABILITY AND FITNESS FOR A PARTICULAR PURPOSE, SHALL APPLY TO THIS PRODUCT AS PROVIDED UNDER APPLICABLE LAW. IF ANY PRODUCT TO WHICH THIS LIMITED WARRANTY APPLIES IS A "CONSUMER PRODUCT" UNDER THE MAGNUSON-MOSS WARRANTY ACT (15 U.S.C.A. §2301, ET SEQ.) OR OTHER APPLICABLE LAW, THE FOREGOING DISCLAIMER OF IMPLIED WARRANTIES SHALL NOT APPLY TO YOU, AND ALL IMPLIED WARRANTIES ON THIS PRODUCT, INCLUDING WARRANTIES OF MERCHANTABILITY AND FITNESS FOR THE PARTICULAR PURPOSE, SHALL APPLY AS PROVIDED UNDER APPLICABLE LAW.

Other Conditions

This limited warranty gives you specific legal rights, and you may have other rights which vary from country to country or state to state.

This limited warranty is void if (i) the label bearing the serial number of this product has been removed or defaced, (ii) the product is not distributed by Kramer Electronics or (iii) this product is not purchased from an authorized Kramer Electronics reseller. If you are unsure whether a reseller is an authorized Kramer Electronics reseller, visit our web site at www.kramerav.com or contact a Kramer Electronics office from the list at the end of this document.

Your rights under this limited warranty are not diminished if you do not complete and return the product registration form or complete and submit the online product registration form. Kramer Electronics thanks you for purchasing a Kramer Electronics product. We hope it will give you years of satisfaction.



HDMI™
HIGH-DEFINITION MULTIMEDIA INTERFACE



P/N: 2900-301641

Rev: 1



SAFETY WARNING

Disconnect the unit from the power supply before opening and servicing

For the latest information on our products and a list of Kramer distributors, visit our website where updates to this user manual may be found.

We welcome your questions, comments, and feedback.

The terms HDMI, HDMI High-Definition Multimedia Interface, and the HDMI Logo are trademarks or registered trademarks of HDMI Licensing Administrator, Inc. All brand names, product names, and trademarks are the property of their respective owners.