



KRAMER ELECTRONICS LTD.

USER MANUAL

MODELS:

WP-580T

HDMI Line Transmitter

WP-580R

HDMI Line Receiver

P/N: 2900-300094 Rev 5



WP-580T and WP-580R Quick Start Guide

This guide helps you install and use your product for the first time. For more detailed information, go to http://www.kramerelectronics.com/support/product_downloads.asp to download the latest manual or scan the QR code on the left.

Step 1: Check what's in the box

- WP-580T HDMI Line Transmitter and/or WP-580R HDMI Line Receiver
- 1 Quick start guide
- Power adapter (5V DC) for each device

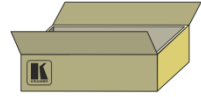

Save the original box and packaging materials in case you need to return your product for service.

Step 2: Mount the Transmitter and Receiver

Connect the TP cable between the WP-580T and WP-580R and then mount them in suitable wall boxes.

Step 3: Connect inputs and outputs

For best results, we recommend that you always use Kramer high-performance cables to connect AV equipment to the WP-580T and WP-580R. For optimum range and performance use Kramer's BC-HDKat6a cable. Note that the transmission range depends on the signal resolution, graphics card and display used. The distance using non-Kramer CAT 6 cable may not reach these ranges. Use only shielded cable where both ends of the shield are soldered to ground.

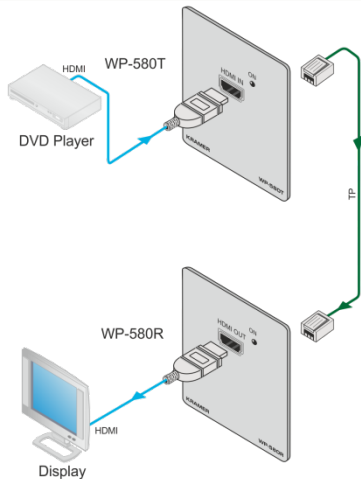

Twisted Pair Pinout

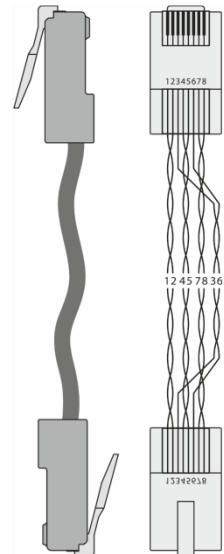

EIA / TIA 568B	
PIN	Wire Color
1	Orange / White
2	Orange
3	Green / White
4	Blue
5	Blue / White
6	Green
7	Brown / White
8	Brown

Step 4: Connect the power

Connect the power adapters to the WP-580T and WP-580R and plug the adapters into the mains electricity.

Contents

1	Introduction	1
2	Getting Started	2
2.1	Achieving the Best Performance	2
2.2	Safety Instructions	2
2.3	Recycling Kramer Products	3
3	Overview	4
3.1	About HDBaseT™ Technology	5
3.2	Using Twisted Pair Cable	5
4	Defining the WP-580T HDMI Line Transmitter	6
5	Defining the WP-580R HDMI Line Receiver	8
6	Connecting the WP-580T Transmitter to the WP-580R Receiver	10
6.1	Wiring the TP LINE IN / LINE OUT RJ-45 Connectors	12
6.2	Grounding the Transmitter/Receiver	13
7	Technical Specifications	14

Figures

Figure 1:	WP-580T HDMI Line Transmitter for the US and US-D Sizes	6
Figure 2:	WP-580T HDMI Line Transmitter for Europe (80mm/86mm)	7
Figure 3:	WP-580R HDMI Line Receiver for the US and US-D Sizes	8
Figure 4:	WP-580R HDMI Line Receiver for Europe (80mm/86mm)	9
Figure 5:	Connecting the WP-580T/WP-580R Transmitter/Receiver	11
Figure 6:	TP PINOUT	12
Figure 7:	Grounding Connection Components	13

1 Introduction

Welcome to Kramer Electronics! Since 1981, Kramer Electronics has been providing a world of unique, creative, and affordable solutions to the vast range of problems that confront video, audio, presentation, and broadcasting professionals on a daily basis. In recent years, we have redesigned and upgraded most of our line, making the best even better!

Our 1,000-plus different models now appear in 13 groups that are clearly defined by function: GROUP 1: Distribution Amplifiers; GROUP 2: Switchers and Routers; GROUP 3: Control Systems; GROUP 4: Format/Standards Converters; GROUP 5: Range Extenders and Repeaters; GROUP 6: Specialty AV Products; GROUP 7: Scan Converters and Scalers; GROUP 8: Cables and Connectors; GROUP 9: Room Connectivity; GROUP 10: Accessories and Rack Adapters; GROUP 11: Sierra Video Products; GROUP 12: Digital Signage; and GROUP 13: Audio.

Congratulations on purchasing your Kramer **WP-580T** transmitter and/or **WP-580R** receiver (for the US, Europe and/or US-D wall plates), which can be part of a transmitter/receiver system and is ideal for the following typical applications:

- Conference rooms, boardrooms, auditoriums, hotels, churches, classrooms and production studios
- Rental and staging



Note that **WP-580T** and **WP-580R** are purchased separately, and can be connected to other HDBaseT certified transmitters and receivers, respectively.

2 Getting Started

We recommend that you:

- Unpack the equipment carefully and save the original box and packaging materials for possible future shipment
- Review the contents of this user manual



Go to www.kramerav.com/manual/WP-580T to check for up-to-date user manuals, application programs, and to check if firmware upgrades are available (where appropriate).

2.1 Achieving the Best Performance

To achieve the best performance:

- Use only good quality connection cables (we recommend Kramer high-performance, high-resolution cables) to avoid interference, deterioration in signal quality due to poor matching, and elevated noise levels (often associated with low quality cables)
- Do not secure the cables in tight bundles or roll the slack into tight coils
- Avoid interference from neighboring electrical appliances that may adversely influence signal quality
- Position your Kramer **WP-580T** transmitter and **WP-580R** receiver away from moisture, excessive sunlight and dust



This equipment is to be used only inside a building. It may only be connected to other equipment that is installed inside a building.

2.2 Safety Instructions



Caution: There are no operator serviceable parts inside the unit

Warning: Use only the Kramer Electronics input power wall adapter that is provided with the unit

Warning: Disconnect the power and unplug the unit from the wall before installing

2.3 Recycling Kramer Products

The Waste Electrical and Electronic Equipment (WEEE) Directive 2002/96/EC aims to reduce the amount of WEEE sent for disposal to landfill or incineration by requiring it to be collected and recycled. To comply with the WEEE Directive, Kramer Electronics has made arrangements with the European Advanced Recycling Network (EARN) and will cover any costs of treatment, recycling and recovery of waste Kramer Electronics branded equipment on arrival at the EARN facility. For details of Kramer's recycling arrangements in your particular country go to our recycling pages at www.kramerav.com/support/recycling/.

3 Overview

The **WP-580T** and **WP-580R** are a high-performance, HDBaseT technology Twisted Pair transmitter and receiver for HDMI signals. The **WP-580T** converts the HDMI signal to a twisted pair signal. The **WP-580R** converts the twisted pair signal back into an HDMI signal.

The **WP-580T** and the **WP-580R** can form a transmission and reception system either together or each device separately with another certified HDBaseT device. For example, the transmitter and receiver system can be composed of the **WP-580T** that connects to the Kramer **TP-580R** to form a transmitter receiver pair.

The **WP-580T** transmitter and **WP-580R** receiver feature:

- A bandwidth of up to 10.2Gbps (3.4Gbps per graphic channel), supporting 2K resolution
- System Range - Up to 70 meters (230 feet)
- HDBaseT technology
- HDTV compatibility and HDCP compliance
- HDMI support - HDMI (deep color, x.v.Color™, lip sync, HDMI uncompressed audio channels, Dolby TrueHD, DTS-HD, CEC, 2K, 3D)
- EDID pass-through - passes EDID signals from the source to the display
- LED status indicators for power
- Wall plate size of 2 gang EU/US/US-D



For optimum range and performance using HDBaseT™, use Kramer's **BC-HDKat6a** cable. Note that the transmission range depends on the signal resolution, source and display used. The distance using non-Kramer CAT 6 cable may not reach these ranges.

3.1 About HDBaseT™ Technology

HDBaseT™ is an advanced all-in-one connectivity technology (Supported by the HDBaseT Alliance). It is particularly suitable in the consumer home environment as a digital home networking alternative where it enables you to replace numerous cables and connectors by a single LAN cable used to transmit, for example, uncompressed full high-definition video, audio, IR, as well as various control signals.



The products described in this user manual are HDBaseT certified.

3.2 Using Twisted Pair Cable

Kramer engineers have developed special twisted pair cables to best match our digital twisted pair products; the Kramer **BC-HDKat6a** (CAT 6 23 AWG cable) significantly outperforms regular CAT 5 / CAT 6 cables.

4 Defining the WP-580T HDMI Line Transmitter

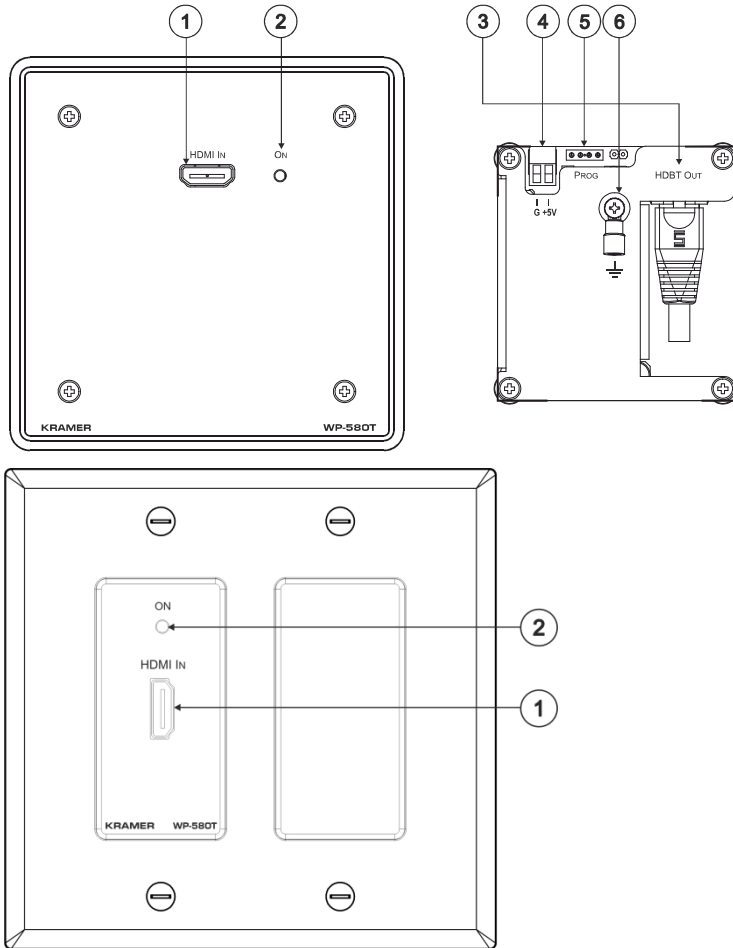

Figure 1: WP-580T HDMI Line Transmitter for the US and US-D Sizes



Note that the US-D wall plate is supplied with a Midway Size 2 gang DECORA® design frame. You can also fit it into a different sized DECORA® design frame (not supplied) such as Standard Size or Oversized.

DECORA® is a registered trademark of Leviton Manufacturing Co., Inc.

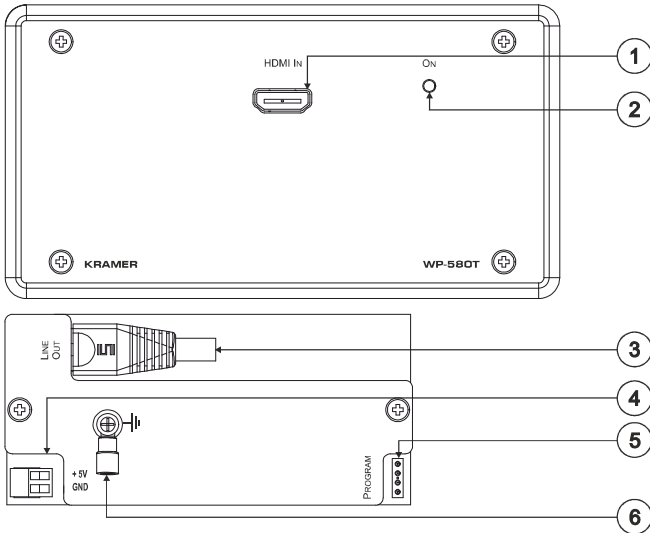

Figure 2: WP-580T HDMI Line Transmitter for Europe (80mm/86mm)

#	Feature	Function
1	HDMI IN Connector	Connects to the HDMI source
2	ON LED	Lights red when only the power is connected; orange when the power and the input only are connected; and green when the power and both the input and output are connected Note, if no input is connected the device invokes the power save mode automatically turning off the power
3	HDBT OUT/LINE OUT RJ-45 Connector	Connects to the HDBT IN/LINE IN RJ-45 connector on the WP-580R
4	+5V DC	+5V DC connector for powering the unit
5	PROG 4-pin Connector	For internal use
6	Grounding Screw	Connect to grounding wire, see Section 6.2

5 Defining the WP-580R HDMI Line Receiver

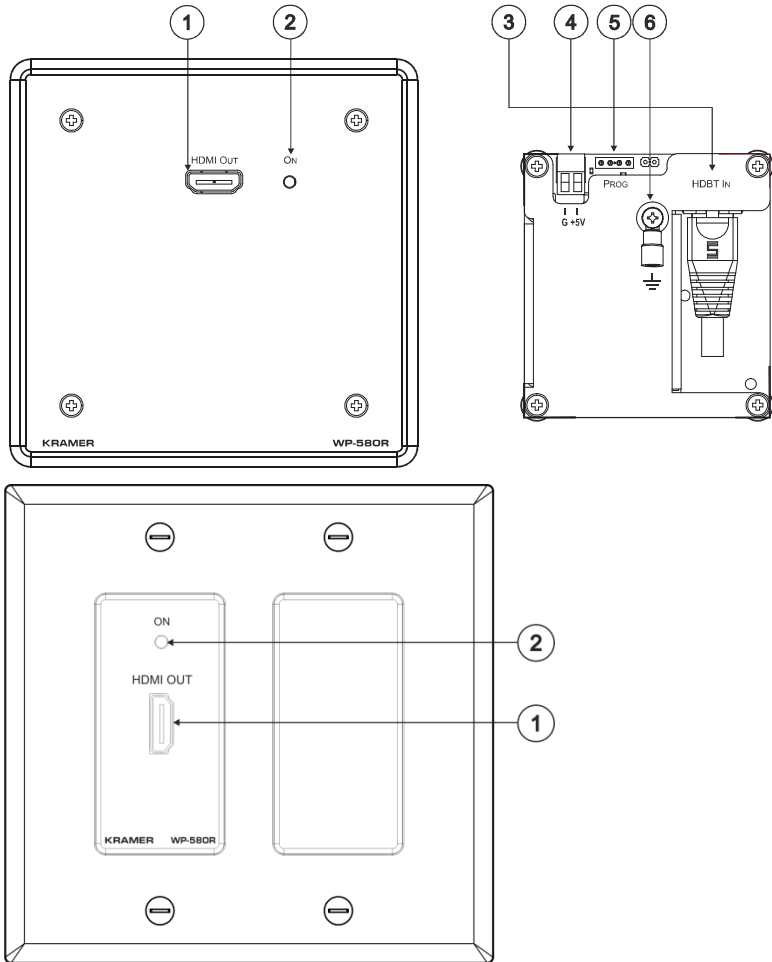

Figure 3: WP-580R HDMI Line Receiver for the US and US-D Sizes



Note that the US-D wall plate is supplied with a Midway Size 2 gang DECORA® design frame. You can also fit it into a different sized DECORA® design frame (not supplied) such as Standard Size or Oversized.

DECORA® is a registered trademark of Leviton Manufacturing Co., Inc.

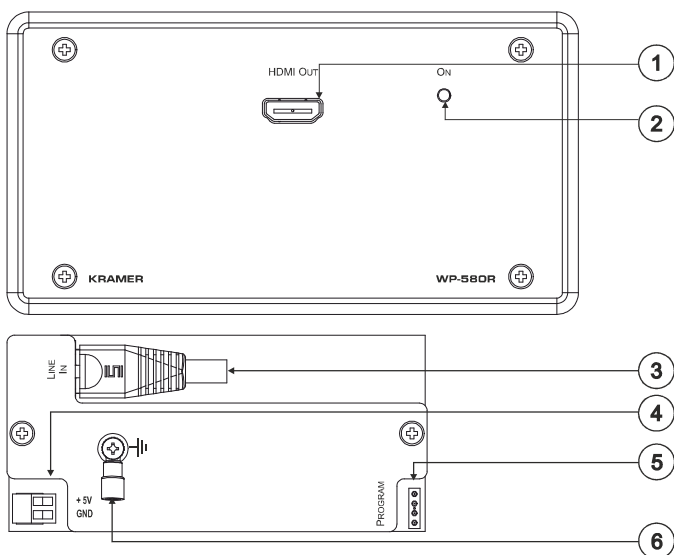

Figure 4: WP-580R HDMI Line Receiver for Europe (80mm/86mm)

#	Feature	Function
1	HDMI OUT Connector	Connects to the HDMI acceptor
2	ON LED	Lights red when the power is connected or the power and output are connected; orange when the power and the input only are connected; and green when the power and both the input and output are connected Note, if no input is connected the device invokes the power save mode automatically turning off the power
3	HDBT IN/LINE IN RJ-45 Connector	Connects to the HDBT OUT/LINE OUT RJ-45 connector on the WP-580T
4	+5V DC	+5V DC connector for powering the unit
5	PROGRAM 4-pin Connector	For internal use
6	Grounding Screw (optional)	Connect to grounding wire, see Section 6.2 (for European versions only)

6 Connecting the WP-580T Transmitter to the WP-580R Receiver



Always switch off the power to each device before connecting it to your transmitter and receiver. After connecting your transmitter and receiver, connect their power and then switch on the power to each device.

You can use the **WP-580T** HDMI Line Transmitter and the **WP-580R** HDMI Line Receiver to configure an HDMI transmitter/receiver system, as illustrated in the example in [Figure 5](#).

To connect the **WP-580T**:

1. Connect the HDMI source (for example, a DVD player) to the HDMI IN connector.
2. Connect the LINE OUT RJ-45 connector over twisted pair to the **WP-580R** LINE IN connector.
Alternatively, you can use any other certified HDBaseT receiver device (for example, the Kramer **TP-580R**)
3. Connect the 5V DC power adapter to the power socket and connect the adapter to the mains electricity (not shown in [Figure 5](#)).

To connect the **WP-580R**:

4. Connect the HDMI OUT connector to the HDMI acceptor (for example, a display).
5. Connect the LINE IN RJ-45 connector over twisted pair to the **WP-580T** LINE OUT connector.
Alternatively, you can use any other certified HDBaseT transmitter device (for example, the Kramer **TP-580T**)
6. Connect the 5V DC power adapter to the power socket and connect the adapter to the mains electricity (not shown in [Figure 5](#)).

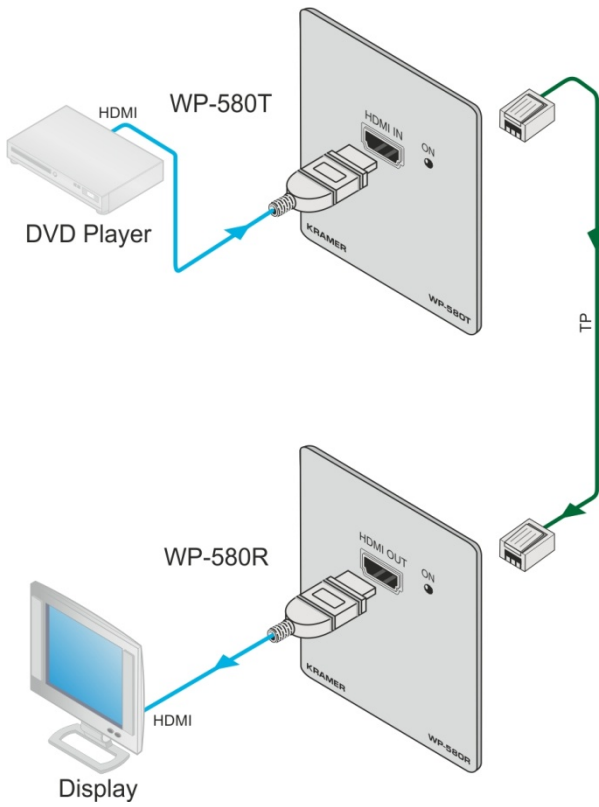

Figure 5: Connecting the WP-580T/WP-580R Transmitter/Receiver

6.1 Wiring the TP LINE IN / LINE OUT RJ-45 Connectors

This section defines the TP pinout, using a **straight** pin-to-pin cable with RJ-45 connectors.

EIA / TIA 568B	
PIN	Wire Color
1	Orange / White
2	Orange
3	Green / White
4	Blue
5	Blue / White
6	Green
7	Brown / White
8	Brown

Figure 6: TP PINOUT

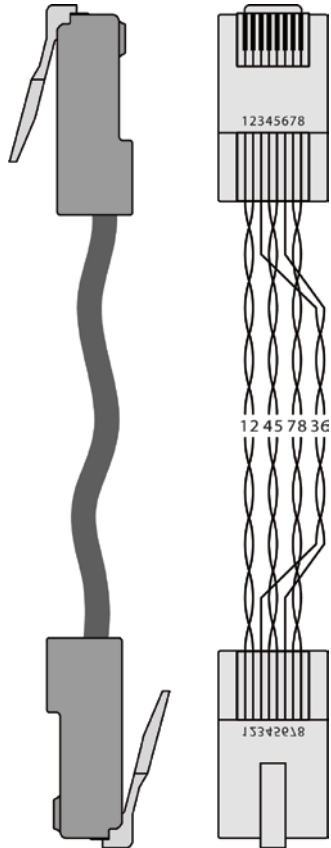

6.2 Grounding the Transmitter/Receiver

The grounding screw is used to earth the chassis of the unit to the building ground preventing static electricity from impacting the performance of the unit.

[Figure 7](#) defines the grounding screw components.

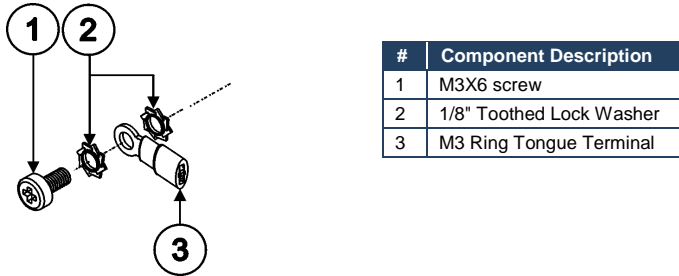

Figure 7: Grounding Connection Components

To ground the room controller:

1. Connect the Ring Tongue terminal to the building grounding point wire (it is recommended to use a green-yellow AWG#18 (0.82mm²) wire, crimped with a proper hand-tool).
2. Insert the M3x6 screw through the toothed lock washers and the tongue terminal in the order shown above.
3. Insert the M3x6 screw (with the two toothed lock washers and ring tongue terminal) into the grounding screw hole and tighten the screw.

7 Technical Specifications

	WP-580T	WP-580R
INPUTS:	1 HDMI connector	1 RJ-45 connector
OUTPUTS:	1 RJ-45 connector	1 HDMI connector
BANDWIDTH:	Supports up to 3.4Gbps bandwidth per graphic channel	
COMPLIANCE WITH HDMI STANDARD:	Supports HDMI and HDCP	
POWER SOURCE:	5V DC, 360mA	5V DC, 930mA
OPERATING TEMPERATURE:	0° to +40°C (32° to 104°F)	
STORAGE TEMPERATURE:	-40° to +70°C (-40° to 158°F)	
HUMIDITY:	10% to 90%, RHL non-condensing	
DIMENSIONS:	2 gang for the USA: 11.4cm x 2.6cm x 11.4cm (4.49" x 1.02" x 4.49", W, D, H) 2 gang for Europe: 15.2cm x 1.9cm x 8.6cm (5.98" x 0.75" x 3.39", W, D, H) 2 gang (Midway Size) for US-D: 12.6cm x 2.5cm x 12.4cm (4.95" x 1" x 4.88"), W, D, H	
WEIGHT:	0.6kg (1.4lbs)	
INCLUDED ACCESSORIES:	Power supply	
OPTIONS:	Kramer BC-HDKat6a cable	
Specifications are subject to change without notice Go to our Web site at www.kramerav.com to access the list of resolutions		

LIMITED WARRANTY

The warranty obligations of Kramer Electronics for this product are limited to the terms set forth below:

What is Covered

This limited warranty covers defects in materials and workmanship in this product.

What is Not Covered

This limited warranty does not cover any damage, deterioration or malfunction resulting from any alteration, modification, improper or unreasonable use or maintenance, misuse, abuse, accident, neglect, exposure to excess moisture, fire, improper packing and shipping (such claims must be presented to the carrier), lightning, power surges, or other acts of nature. This limited warranty does not cover any damage, deterioration or malfunction resulting from the installation or removal of this product from any installation, any unauthorized tampering with this product, any repairs attempted by anyone unauthorized by Kramer Electronics to make such repairs, or any other cause which does not relate directly to a defect in materials and/or workmanship of this product. This limited warranty does not cover cartons, equipment enclosures, cables or accessories used in conjunction with this product.

Without limiting any other exclusion herein, Kramer Electronics does not warrant that the product covered hereby, including, without limitation, the technology and/or integrated circuit(s) included in the product, will not become obsolete or that such items are or will remain compatible with any other product or technology with which the product may be used.

How Long Does this Coverage Last

Seven years as of this printing; please check our Web site for the most current and accurate warranty information.

Who is Covered

Only the original purchaser of this product is covered under this limited warranty. This limited warranty is not transferable to subsequent purchasers or owners of this product.

What Kramer Electronics will do

Kramer Electronics will, at its sole option, provide one of the following three remedies to whatever extent it shall deem necessary to satisfy a proper claim under this limited warranty:

1. Elect to repair or facilitate the repair of any defective parts within a reasonable period of time, free of any charge for the necessary parts and labor to complete the repair and restore this product to its proper operating condition. Kramer Electronics will also pay the shipping costs necessary to return this product once the repair is complete.
2. Replace this product with a direct replacement or with a similar product deemed by Kramer Electronics to perform substantially the same function as the original product.
3. Issue a refund of the original purchase price less depreciation to be determined based on the age of the product at the time remedy is sought under this limited warranty.

What Kramer Electronics will not do Under This Limited Warranty

If this product is returned to Kramer Electronics or the authorized dealer from which it was purchased or any other party authorized to repair Kramer Electronics products, this product must be insured during shipment, with the insurance and shipping charges prepaid by you. If this product is returned uninsured, you assume all risks of loss or damage during shipment. Kramer Electronics will not be responsible for any costs related to the removal or re-installation of this product from or into any installation. Kramer Electronics will not be responsible for any costs related to any setting up this product, any adjustment of user controls or any programming required for a specific installation of this product.

How to Obtain a Remedy under this Limited Warranty

To obtain a remedy under this limited warranty, you must contact either the authorized Kramer Electronics reseller from whom you purchased this product or the Kramer Electronics office nearest you. For a list of authorized Kramer Electronics resellers and/or Kramer Electronics authorized service providers, please visit our web site at www.kramerelectronics.com or contact the Kramer Electronics office nearest you.

In order to pursue any remedy under this limited warranty, you must possess an original, dated receipt as proof of purchase from an authorized Kramer Electronics reseller. If this product is returned under this limited warranty, a return authorization number, obtained from Kramer Electronics, will be required. You may also be directed to an authorized reseller or a person authorized by Kramer Electronics to repair the product.

If it is decided that this product should be returned directly to Kramer Electronics, this product should be properly packed, preferably in the original carton, for shipping. Cartons not bearing a return authorization number will be refused.

Limitation on Liability

THE MAXIMUM LIABILITY OF KRAMER ELECTRONICS UNDER THIS LIMITED WARRANTY SHALL NOT EXCEED THE ACTUAL PURCHASE PRICE PAID FOR THE PRODUCT. TO THE MAXIMUM EXTENT PERMITTED BY LAW, KRAMER ELECTRONICS IS NOT RESPONSIBLE FOR DIRECT, SPECIAL, INCIDENTAL OR CONSEQUENTIAL DAMAGES RESULTING FROM ANY BREACH OF WARRANTY OR CONDITION, OR UNDER ANY OTHER LEGAL THEORY. Some countries, districts or states do not allow the exclusion or limitation of relief, special, incidental, consequential or indirect damages, or the limitation of liability to specified amounts, so the above limitations or exclusions may not apply to you.

Exclusive Remedy

TO THE MAXIMUM EXTENT PERMITTED BY LAW, THIS LIMITED WARRANTY AND THE REMEDIES SET FORTH ABOVE ARE EXCLUSIVE AND IN LIEU OF ALL OTHER WARRANTIES, REMEDIES AND CONDITIONS, WHETHER ORAL OR WRITTEN, EXPRESS OR IMPLIED. TO THE MAXIMUM EXTENT PERMITTED BY LAW, KRAMER ELECTRONICS SPECIFICALLY DISCLAIMS ANY AND ALL IMPLIED WARRANTIES, INCLUDING, WITHOUT LIMITATION, WARRANTIES OF MERCHANTABILITY AND FITNESS FOR A PARTICULAR PURPOSE. IF KRAMER ELECTRONICS CANNOT LAWFULLY DISCLAIM OR EXCLUDE IMPLIED WARRANTIES UNDER APPLICABLE LAW, THEN ALL IMPLIED WARRANTIES COVERING THIS PRODUCT, INCLUDING WARRANTIES OF MERCHANTABILITY AND FITNESS FOR A PARTICULAR PURPOSE, SHALL APPLY TO THIS PRODUCT AS PROVIDED UNDER APPLICABLE LAW.

IF ANY PRODUCT TO WHICH THIS LIMITED WARRANTY APPLIES IS A "CONSUMER PRODUCT" UNDER THE MAGNUSON-MOSS WARRANTY ACT (15 U.S.C.A. §2301, ET SEQ.) OR OTHER APPLICABLE LAW, THE FOREGOING DISCLAIMER OF IMPLIED WARRANTIES SHALL NOT APPLY TO YOU, AND ALL IMPLIED WARRANTIES ON THIS PRODUCT, INCLUDING WARRANTIES OF MERCHANTABILITY AND FITNESS FOR THE PARTICULAR PURPOSE, SHALL APPLY AS PROVIDED UNDER APPLICABLE LAW.

Other Conditions

This limited warranty gives you specific legal rights, and you may have other rights which vary from country to country or state to state.

This limited warranty is void if (i) the label bearing the serial number of this product has been removed or defaced, (ii) the product is not distributed by Kramer Electronics or (iii) this product is not purchased from an authorized Kramer Electronics reseller. If you are unsure whether a reseller is an authorized Kramer Electronics reseller, please visit our Web site at www.kramerelectronics.com or contact a Kramer Electronics office from the list at the end of this document.

Your rights under this limited warranty are not diminished if you do not complete and return the product registration form or complete and submit the online product registration form. Kramer Electronics thanks you for purchasing a Kramer Electronics product. We hope it will give you years of satisfaction.



For the latest information on our products and a list of Kramer distributors, visit our Web site where updates to this user manual may be found.

We welcome your questions, comments, and feedback.

Web site: www.kramerav.com

E-mail: info@kramerav.com

CE



SAFETY WARNING

Disconnect the unit from the power supply before opening and servicing



P/N: 2900-300094



Rev: 5