



FUZE WASH 500™
user manual

©2024 ELATION PROFESSIONAL all rights reserved. Information, specifications, diagrams, images, and instructions herein are subject to change without notice. ELATION PROFESSIONAL logo and identifying product names and numbers herein are trademarks of ELATION PROFESSIONAL. Copyright protection claimed includes all forms and matters of copyrightable materials and information now allowed by statutory or judicial law or hereinafter granted. Product names used in this document may be trademarks or registered trademarks of their respective companies and are hereby acknowledged. All non-ELATION brands and product names are trademarks or registered trademarks of their respective companies.

ELATION PROFESSIONAL and all affiliated companies hereby disclaim any and all liabilities for property, equipment, building, and electrical damages, injuries to any persons, and direct or indirect economic loss associated with the use or reliance of any information contained within this document, and/or as a result of the improper, unsafe, insufficient and negligent assembly, installation, rigging, and operation of this product.

Elation Professional USA | 6122 S. Eastern Ave. | Los Angeles, CA. 90040

323-582-3322 | 323-832-9142 fax | www.elationlighting.com | info@elationlighting.com

Elation Professional B.V. | Junostraat 2 | 6468 EW Kerkrade, The Netherlands

+31 45 546 85 66 | +31 45 546 85 96 fax | www.elationlighting.eu | info@elationlighting.eu

Elation Professional Mexico | AV Santa Ana 30 | Parque Industrial Lerma, Lerma, Mexico 52000

+52 (728) 282-7070

DOCUMENT VERSION



Due to additional product features and/or enhancements, an updated version of this document may be available online. Please scan the QR Code with your mobile device or visit www.elationlighting.com for the latest revision/update of this manual, before installation and/or programming.

Date	Document Version	Software Version ≥	DMX Channel Modes	Notes
01/06/2023	1.0	1.3.1	Standard, Extended, CMY, CMY Extended, RGB, RGB Extended	Initial Release
04/04/2023	1.1	N/C	No Change	Updated Accessory Installation, DMX Channel Functions and Values, Specifications, Dimensional Drawings, Optional Accessories
05/24/2023	1.2	N/C	No Change	Updated Fixture Transporting
06/06/2023	1.3	N/C	No Change	Updated Certifications
06/21/2023	1.4	N/C	No Change	Removed Fixture Transport and Handling; updated General Info
02/05/2024	1.5	1.3.7	No Barndoor: 17 / 26 / 15 CMY / 22 CMY Ex / 15 RGB / 22 RGB Ex Barndoor: 21 / 30 / 19 CMY / 26 CMY Ex / 19 RGB / 26 RGB Ex	Updated Accessory Installation, System Menu (Barndoor/No Barndoor), DMX Traits (Barndoor/No Barndoor), RDM, Specifications

CONTENTS

General Information	4
Limited Warranty (USA Only)	5
Safety Guidelines	6
Maintenance Guidelines	8
Overview	9
Fan Control and Low Noise Operation	10
Colors	11
Accessory Installation	12
Snoot	12
Beam Shaper	13
Barndoors	14
Installation Guidelines	16
System Menu	20
Barndoor Mode	21
No Barndoor Mode	24
Color LED Programming Guidelines	27
Dimmer Mode	28
DMX Traits	29
Barndoor Mode	29
No Barndoor Mode	33
Color Temperature Table	37
Virtual Gel Swatch Book Table	38
Remote Device Management (RDM)	39
Error Codes	40
Specifications	41
Dimensions	42
Optional Accessories FCC Statement	44

GENERAL INFORMATION

INTRODUCTION

Please read and understand the instructions in this manual carefully and thoroughly before attempting to operate this device. These instructions contain important safety and use information. **This unit is intended for use by professionally trained personnel only, and is not suitable for private use.**

UNPACKING

Every device has been thoroughly tested and has been shipped in perfect operating condition. Carefully check the shipping carton for damage that may have occurred during shipping. If the carton is damaged, carefully inspect the device for damage, and be sure all accessories necessary to install and operate the device have arrived intact. In the event damage has been found or parts are missing, please contact our customer support team for further instructions. Please do not return this device to your dealer without first contacting customer support. Please do not discard the shipping carton in the trash. Please recycle whenever possible.

BOX CONTENTS

Omega Brackets (x2)
Locking Power Cable
Snoot with screws

CUSTOMER SUPPORT

Contact ELATION Service for any product related service and support needs. Also visit forums.elationlighting.com with questions, comments or suggestions.

ELATION SERVICE USA - Monday - Friday 8:00am to 4:30pm PST
323-582-3322 | Fax 323-832-9142 | support@elationlighting.com

ELATION SERVICE EUROPE - Monday - Friday 08:30 to 17:00 CET
+31 45 546 85 63 | Fax +31 45 546 85 96 | support@elationlighting.eu

REPLACEMENT PARTS please visit parts.elationlighting.com



IMPORTANT NOTICE!

There are no user serviceable parts inside this unit.

Do not attempt any repairs yourself; doing so will void your manufactures warranty. Damages resulting from modifications to this fixture and/or the disregard of safety instructions and guidelines in this manual void the manufactures warranty and are not subject to any warranty claims and/or repairs.

LIMITED WARRANTY (USA ONLY)

- A. Elation Professional hereby warrants, to the original purchaser, Elation Professional products to be free of manufacturing defects in material and workmanship for a period of two years (730 days), and Elation Professional product rechargeable batteries to be free of manufacturing defects in material and workmanship for a period of six months (180 days), from the original date of purchase. This warranty excludes discharge lamps and all product accessories. This warranty shall be valid only if the product is purchased within the United States of America, including possessions and territories. It is the owner's responsibility to establish the date and place of purchase by acceptable evidence, at the time service is sought.
- B. For warranty service, send the product only to the Elation Professional factory. All shipping charges must be pre-paid. If the requested repairs or service (including parts replacement) are within the terms of this warranty, Elation Professional will pay return shipping charges only to a designated point within the United States. If any product is sent, it must be shipped in its original package and packaging material. No accessories should be shipped with the product. If any accessories are shipped with the product, Elation Professional shall have no liability what so ever for loss and/or damage to any such accessories, nor for the safe return thereof.
- C. This warranty is void if the product serial number and/or labels are altered or removed; if the product is modified in any manner which Elation Professional concludes, after inspection, affects the reliability of the product; if the product has been repaired or serviced by anyone other than the Elation Professional factory unless prior written authorization was issued to purchaser by Elation Professional; if the product is damaged because not properly maintained as set forth in the product instructions, guidelines and/or user manual.
- D. This is not a service contract, and this warranty does not include any maintenance, cleaning or periodic check-up. During the periods as specified above, Elation Professional will replace defective parts at its expense, and will absorb all expenses for warranty service and repair labor by reason of defects in material or workmanship. The sole responsibility of Elation Professional under this warranty shall be limited to the repair of the product, or replacement thereof, including parts, at the sole discretion of Elation Professional. All products covered by this warranty were manufactured after January 1, 1990, and bare identifying marks to that effect.
- E. Elation Professional reserves the right to make changes in design and/or performance improvements upon its products without any obligation to include these changes in any products theretofore manufactured.
- F. No warranty, whether expressed or implied, is given or made with respect to any accessory supplied with the products described above. Except to the extent prohibited by applicable law, all implied warranties made by Elation Professional in connection with this product, including warranties of merchantability or fitness, are limited in duration to the warranty periods set forth above. And no warranties, whether expressed or implied, including warranties of merchantability or fitness, shall apply to this product after said periods have expired. The consumer's and/or dealer's sole remedy shall be such repair or replacement as is expressly provided above; and under no circumstances shall Elation Professional be liable for any loss and/or damage, direct and/or consequential, arising out of the use of, and/or the inability to use, this product.
- G. This warranty is the only written warranty applicable to Elation Professional products and supersedes all prior warranties and written descriptions of warranty terms and conditions heretofore published.

WARRANTY RETURNS

All returned service items whether under warranty or not, must be freight pre-paid and accompany a return authorization (R.A.) number. The R.A. number must be clearly written on the outside of the return package. A brief description of the problem as well as the R.A. number must also be written down on a piece of paper and included in the shipping container. If the unit is under warranty, you must provide a copy of your proof of purchase invoice. Items returned without a R.A. number clearly marked on the outside of the package will be refused and returned at customer's expense. You may obtain a R.A. number by contacting customer support.

SAFETY GUIDELINES

This fixture is a sophisticated piece of electronic equipment. To guarantee a smooth operation, it is important to follow all instructions and guidelines in this manual. Elation Professional is not responsible for injury and/or damages resulting from the misuse of this fixture due to the disregard of the information printed in this manual. Only qualified and/or certified personnel should perform installation of this fixture and only the original rigging parts (omega brackets) included with this fixture should be used for installation. Any modifications to the fixture and/or the included mounting hardware will void the original manufacturer's warranty and increase the risk of damage and/or personal injury.



PROTECTION CLASS 1 - FIXTURE MUST BE PROPERLY GROUNDED



THERE ARE NO USER SERVICEABLE PARTS INSIDE THIS UNIT. DO NOT ATTEMPT ANY REPAIRS YOURSELF; DOING SO WILL VOID YOUR MANUFACTURER'S WARRANTY. DAMAGES RESULTING FROM MODIFICATIONS TO THIS FIXTURE AND/OR THE DISREGARD OF SAFETY INSTRUCTIONS AND GUIDELINES IN THIS MANUAL VOID THE MANUFACTURER'S WARRANTY AND ARE NOT SUBJECT TO ANY WARRANTY CLAIMS AND/OR REPAIRS.



**DO NOT PLUG FIXTURE INTO A DIMMER PACK!
NEVER OPEN THIS FIXTURE WHILE IN USE!
UNPLUG POWER BEFORE SERVICING FIXTURE!
NEVER TOUCH FIXTURE DURING OPERATION, AS IT MAY BE HOT!
KEEP FLAMMABLE MATERIALS AWAY FROM FIXTURE!**

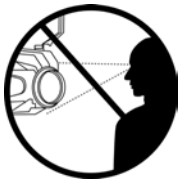

**NEVER LOOK DIRECTLY INTO THE LIGHT SOURCE!
RETINA INJURY RISK - MAY INDUCE BLINDNESS!
SENSITIVE PERSONS MAY SUFFER AN EPILEPTIC SHOCK!**



**INDOOR / DRY LOCATIONS USE ONLY!
DO NOT EXPOSE FIXTURE TO RAIN AND MOISTURE!**



**MINIMUM DISTANCE TO OBJECTS/SURFACES
MUST BE 3.3 FEET (1 METERS)
MAXIMUM TEMP OF EXTERNAL SURFACE 185° F (85°C)
MINIMUM DISTANCE OF INFLAMMABLE MATERIALS
FROM THE SURFACE 1.6 FEET (0.5 METER)**

SAFETY GUIDELINES

DONOT TOUCH the fixture housing during operation. Turn OFF the power and allow approximately 15 minutes for the fixture to cool down before serving.

DO NOT shake fixture, avoid brute force when installing and/or operating fixture.

DO NOT operate fixture if the power cord is frayed, crimped, damaged and/or if any of the power cord connectors are damaged and do not insert into the fixture securely with ease. NEVER force a power cord connector into the fixture. If the power cord or any of its connectors are damaged, replace it immediately with a new one of similar power rating.

DO NOT block any air ventilation slots.

All fan and air inlets must remain clean and never blocked.

Allow approx. 6" (15cm) between fixture and other devices or a wall for proper cooling.

Always disconnect fixture from main power source before performing any type of service and/or cleaning procedure. Only handle the power cord by the plug end, never pull out the plug by tugging the wire portion of the cord.

During the initial operation of this fixture, a light smoke or smell may emit from the interior of the fixture. This is a normal process and is caused by excess paint in the interior of the casing burning off from the heat associated with the lamp and will decrease gradually over time.

Consistent operational breaks will ensure fixture will function properly for many years.

ONLY use the original packaging and materials to transport the fixture in for service.

MAINTENANCE GUIDELINES



DISCONNECT POWER BEFORE PERFORMING ANY MAINTENANCE!

CLEANING

Frequent cleaning is recommended to insure proper function, optimized light output, and an extended life. The frequency of cleaning depends on the environment in which the fixture operates: damp, smoky or particularly dirty environments can cause greater accumulation of dirt on the fixture's optics. Clean the external lens surface at least every 20 days with a soft cloth to avoid dirt/debris accumulation.

NEVER use alcohol, solvents, or ammonia-based cleaners.

MAINTENANCE

Regular inspections are recommended to insure proper function and extended life.

There are no user serviceable parts inside this fixture, please refer all other service issues to an authorized Elation service technician. Should you need any spare parts, please order genuine parts from an authorized Elation dealer.

Please refer to the following points during routine inspections:

A detailed electric check by an approved electrical engineer every three months, to make sure the circuit contacts are in good condition and prevent overheating.

Be sure all screws and fasteners are securely tightened at all times. Loose screws may fall out during normal operation resulting in damage or injury as larger parts could fall.

Check for any deformations on the housing, color lenses, rigging hardware and rigging points (ceiling, suspension, trussing). Deformations in the housing could allow for dust to enter into the fixture. Damaged rigging points or unsecured rigging could cause the fixture to fall and seriously injure a person(s).

Electric power supply cables must not show any damage, material fatigue or sediments.

NEVER remove the ground prong from the power cable.

OVERVIEW

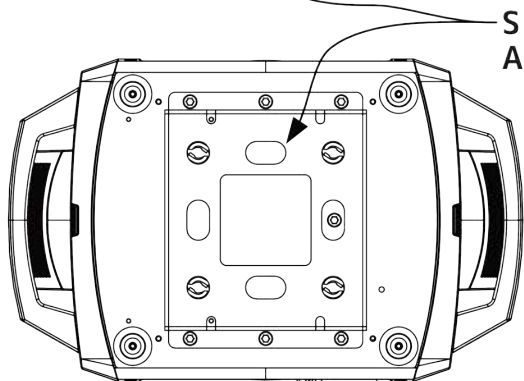
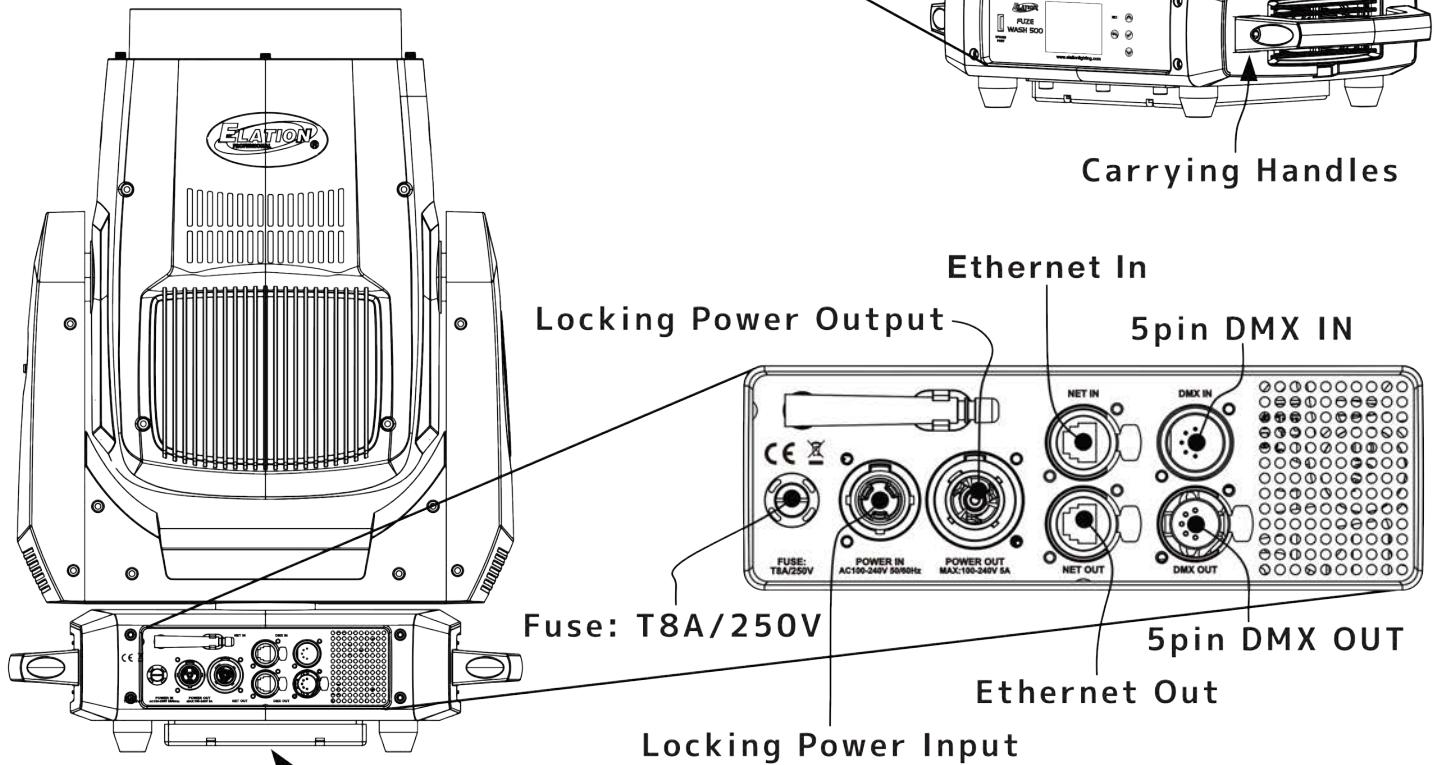
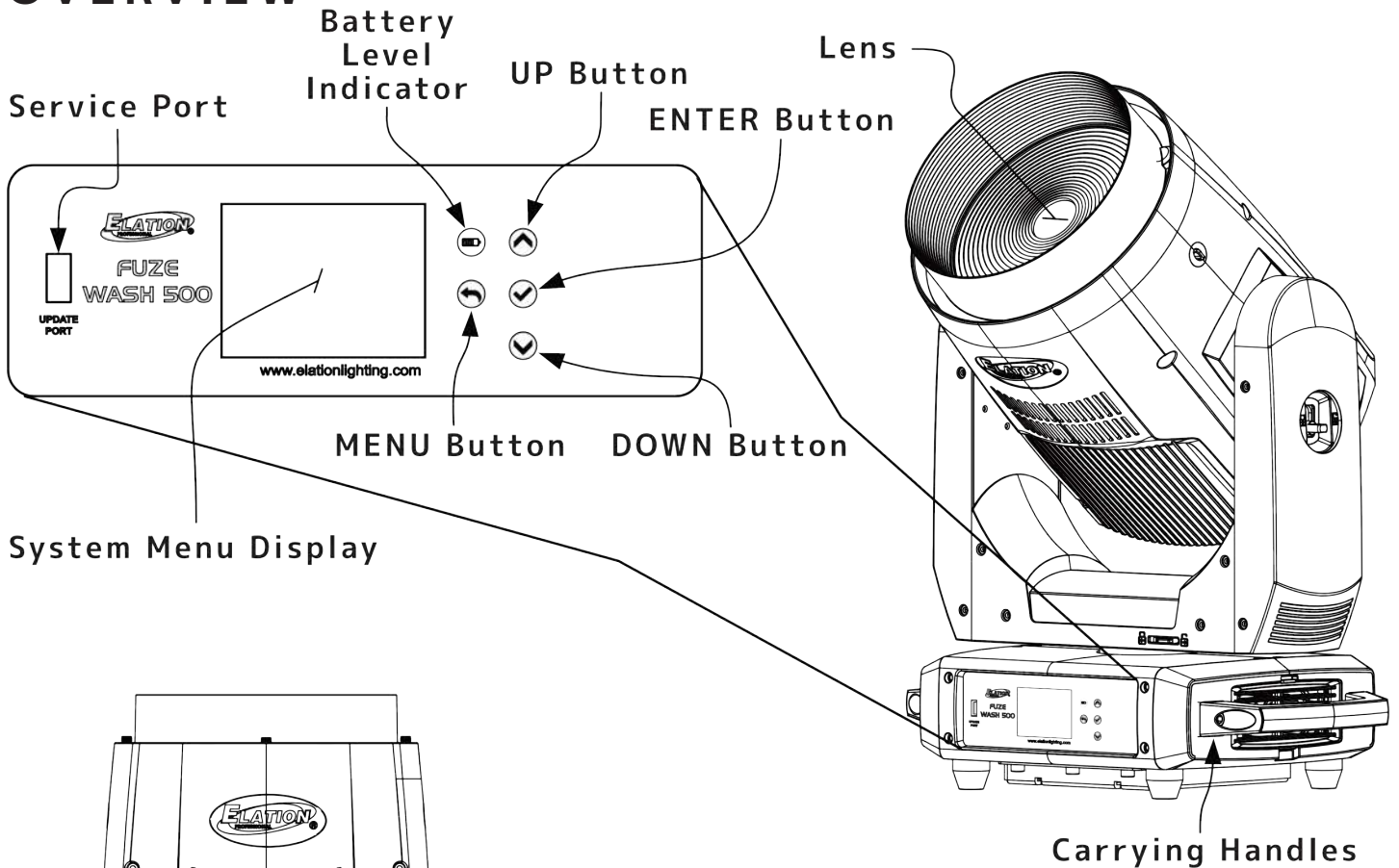

ALWAYS ATTACH A SAFETY CABLE WHENEVER INSTALLING THIS DEVICE IN A SUSPENDED ENVIRONMENT TO ENSURE THE FIXTURE WILL NOT DROP IF THE CLAMP FAILS.

FAN CONTROL AND LOW NOISE OPERATION

The Elation Fuze Wash 500 is a high-performance fixture suited for multiple applications. For noise critical environments such as Theater, Opera, or Orchestral Halls, it offers various fan operation modes which remove unwanted noise distractions for the audience and performers. Fan Modes can be changed remotely via the DMX control channel, allowing the fixture to offer high output or whisper-silent operation at a moment's notice. All Fan Modes smoothly transition over a brief period, preventing unwanted attraction to the fixture.

Auto – The default AUTO mode ensures optimal performance of the fixture. Fans only run at the speeds needed to keep the LED engine within a safe temperature range. They will turn off if possible, for example, when the fixture is dimmed to a low intensity. Fans sense the ambient and fixture temperature, and will, always, try to keep noise levels at a minimum. The fixture output will only reduce when the LED engine cannot be cooled down to its safe operating range due to high ambient temperature. **Note: Auto is the recommend mode for daily operation of the Elation Wash 500.**

High – This mode is only required in very high ambient temperatures when automatic fan speed adjustments are not desired. High Fan Speed will cool the fixture most efficiently. This mode will increase wear on the fans and should only be utilized in exceptional circumstances. Fans will always run, even if the fixture is dimmed. Fixture output is kept at 100% unless the LED engine temperature is too high, at which point the fixture will reduce power carefully to ensure safe operation.

Low – In this mode the fixture reduces fan speeds throughout for a lower noise profile of the fixture. This mode should be sufficient for most uses where lower noise is required. The fixture output is reduced to about 80%.

Additional Low Noise Modes

For very critical situations, the Fuze Wash 500 offers two additional low noise modes for silent operation. The fixture output will be reduced, but as the Fuze Wash 500 has such an extremely high luminous flux, it still offers outstanding performance. In low noise modes, all parameters of the Rembrandt operate quieter and with reduced speeds.

Studio – This mode reduces the fixture output to approximately 50%. Almost all fans inside the Rembrandt are turned off, and only run when necessary to keep the fixture at 50% LED power.

Mute – Running the fixture in MUTE mode reduces the fixture to about 25% output, and all fans are off. The fixture is totally silent.

COLORS

Colors	Color Temperature	Green Shift
Cyan	2400K – 8500K	Full Minus Green to Neutral
Magenta		
Yellow		
Red		Neutral White
Green		
Blue		Neutral to Full Plus Green
Mint		
Amber		

VIRTUAL GEL SWATCH BOOK COLORS								
Value	Filter Number	Name	Value	Filter Number	Name	Value	Filter Number	Name
1	7	Pale Yellow	21	157	Pink	41	68	Sky Blue
2	103	Straw	22	36	Medium Pink	42	143	Pale Navy Blue
3	151	Gold Tint	23	111	Dark Pink	43	131	Marine Blue
4	100	Spring Yellow	24	128	Bright Pink	44	115	Peacock Blue
5	10	Medium Yellow	25	148	Bright Rose	45	172	Lagoon Blue
6	101	Yellow	26	332	Special Rose Pink	46	116	Medium Blue Green
7	104	Deep Amber	27	793	Vanity Fair	47	90	Dark Yellow Green
8	15	Deep Straw	28	113	Magenta	48	139	Primary Green
9	179	Loving Amber	29	46	Dark Magenta	49	122	Fern Green
10	21	Gold Amber	30	48	Rose Purple	50	89	Moss Green
11	105	Orange	31	126	Mauve	51	124	Dark Green
12	158	Deep Orange	32	49	Medium Purple	52	88	Lime Green
13	22	Dark Amber	33	58	Lavender	53	138	Pale Green
14	778	Millennium Gold	34	199	Palace Blue	54	203	Quarter CT Blue
15	135	Deep Golden Amber	35	119	Dark Blue	55	202	Half CT Blue
16	24	Scarlet	36	132	Medium Blue	56	201	FULL CT Blue
17	106	Primary Red	37	120	Deep Blue	57	200	Double CT Blue
18	26	Bright Red	38	165	Daylight Blue	58	206	Quarter CT Orange
19	27	Medium Red	39	161	Slate Blue	59	205	Half CT Orange
20	19	Fire	40	118	Light Blue	60	204	FULL CT Orange

ACCESSORY INSTALLATION: SNOOT



NOTE: During normal operation, this unit is intended to work at all times with the Snoot installed.

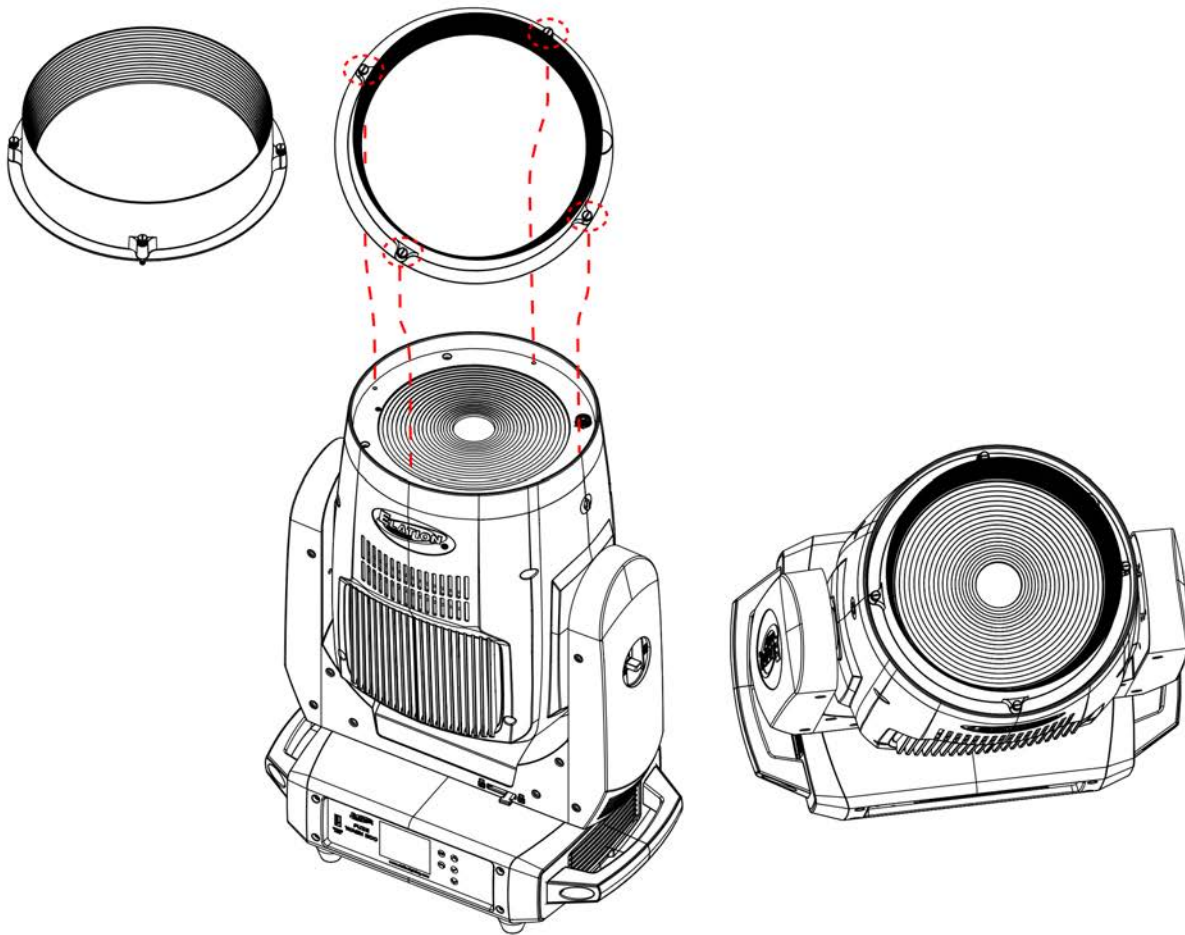

To install either the Beam Shaper or Barndoor, it will be necessary to remove the Snoot.

1. Place fixture on a stable flat surface and let cool for 15mins.
2. Using a hand screwdriver, remove 4 screws.
3. Carefully remove and set aside Snoot in safe location.

If either accessory is removed, it will be necessary to reinstall Snoot:

1. Place fixture on the stable flat surface and let cool for 15mins.
2. Align Snoot onto front lens, making sure that the indentation on the inner edge of the snoot is aligned with the gear on the front of the unit. This should also result in the 4 screw holes on the snoot being correctly aligned with the 4 screw holes on the fixture.
3. Carefully, using a hand screwdriver, insert/secure included 4 screws.
4. Check Snoot to confirm it is seated properly and all 4 screws are secure.



DO NOT OVER TIGHTEN SCREWS! DO NOT USE A POWER SCREWDRIVER!

ACCESSORY INSTALLATION: BEAM SHAPER

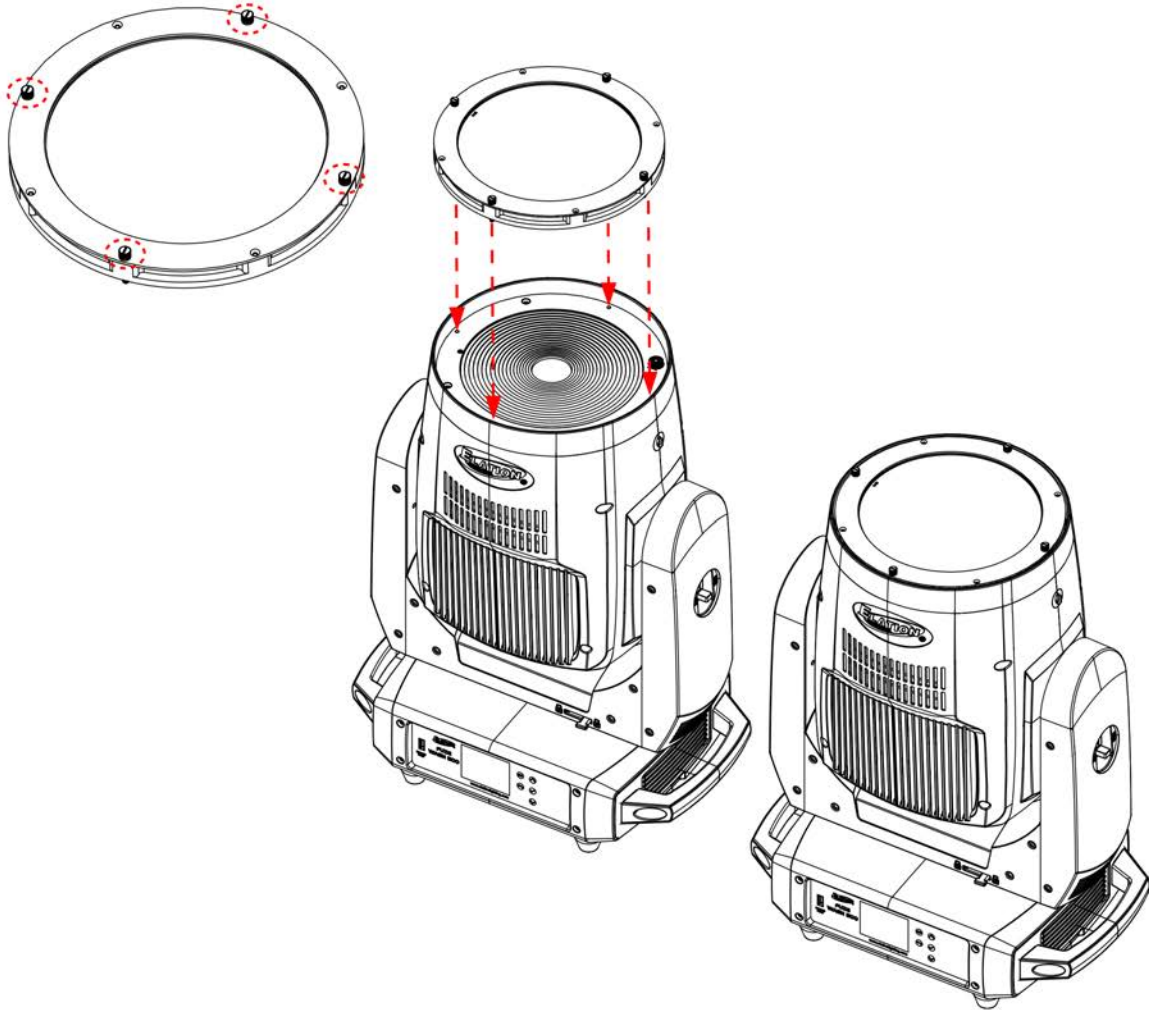

1. Place fixture on the stable flat surface and let cool for 15mins.
2. Align Beam Shaper onto front lens so that the indentation on the inner edge of the beam shaper is aligned with the small gear at the front of the lens. This should also result in the 4 screw holes on the beam shaper being correctly aligned with the 4 screw holes on the fixture.
3. Carefully, using a hand screwdriver, insert/secure included 4 screws.
4. Check Beam Shaper to confirm it is seated properly and all 4 screws are secure.



DO NOT OVER TIGHTEN SCREWS! DO NOT USE A POWER SCREWDRIVER!

ACCESSORY INSTALLATION: BARNDOORS



WHEN BARNDOORS ARE INSTALLED, MAKE SURE TO SET THE UNIT TO BARNDOOR MODE IN THE SYSTEM MENU. FAILURE TO DO SO MAY IMPEDE SOME FUNCTIONS OF THE FIXTURE AND CAUSE DAMAGE TO THE BARNDOOR.

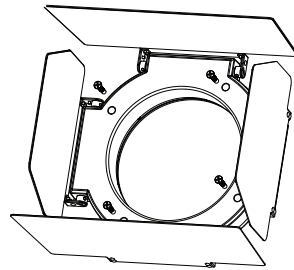
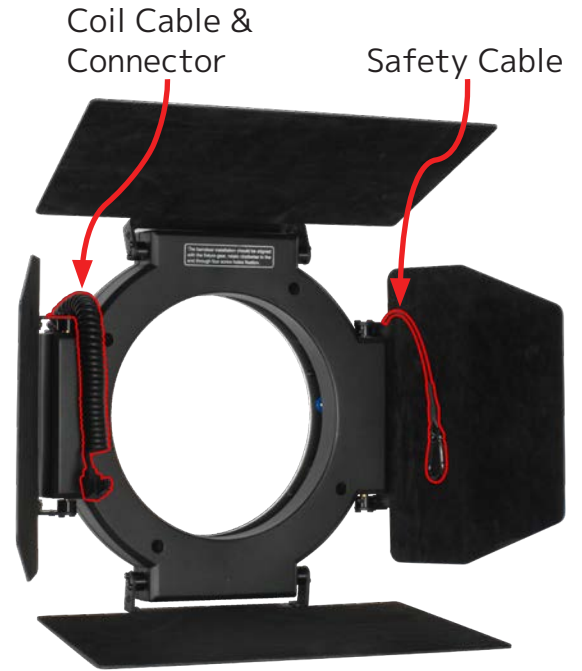

Barndoor Connector Socket

Accessory Safety Cable Attachment Point

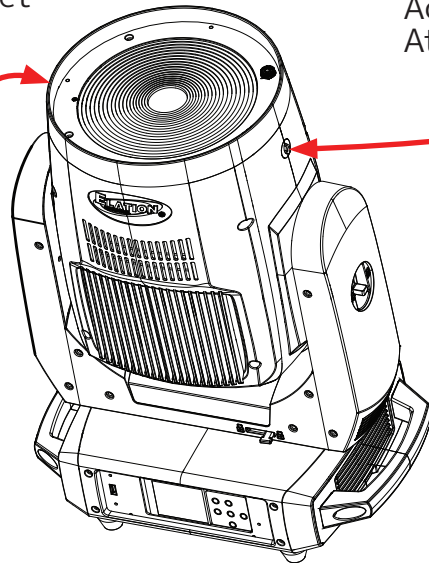

1. Place fixture on the stable flat surface and let cool for 15mins.
2. Before mounting Barndoors, orient the Barndoor assembly to match its Safety Cable/Coil Cable and Connector to the corresponding receptical and Safety Cable Attachment Point on the moving head. Make sure that the indentation on the inner edge of the barndoors is aligned with the gear on the front of the fixture. This should also result in the 4 screw holes on the barndoors being correctly aligned with the 4 screw holes on the fixture.
3. Carefully, using a hand screwdriver, insert/secure included 4 screws.
4. Check Snoot to confirm it is seated properly and all 4 screws are secure.



DO NOT OVER TIGHTEN SCREWS! DO NOT USE A POWER SCREWDRIVER!

ACCESSORY INSTALLATION: BARNDOORS

5. Insert the Power/Data Coil-Cable and Connector of the Barndoor to the Barndoor Power/Data Connector Socket located on the side of the Moving Head, and fasten the Barndoor Safety Cable to the Safety Cable Attachment Point.



6. To disconnect the Power/Data Connector, depress the toggle-lock to disengage it, and with a firm grasp of the connector body, pull connector straight from socket. Follow steps in reverse order to remove the Barndoor.



INSTALLATION GUIDELINES



FLAMMABLE MATERIAL WARNING

Keep fixture minimum 5.0 feet (1.5m) away from flammable materials and/or pyrotechnics.



ELECTRICAL CONNECTIONS

A qualified electrician should be used for all electrical connections and/or installations.



USE CAUTION WHEN POWER LINKING OTHER MODEL FIXTURES AS THE POWER CONSUMPTION OF OTHER MODEL FIXTURES MAY EXCEED THE MAX POWER OUTPUT ON THIS FIXTURE. CHECK SILK SCREEN FOR MAX AMPS.



MINIMUM DISTANCE TO OBJECTS/SURFACES MUST BE 1 FOOT (0.3 METERS)



MINIMUM DISTANCE OF INFLAMMABLE MATERIALS FROM THE SURFACE 1.6 FEET (0.5 METER)



MAXIMUM AMBIENT TEMPERATURE 113° F (45°C)



DO NOT INSTALL THE FIXTURE IF YOU ARE NOT QUALIFIED TO DO SO!

Fixture **MUST** be installed following all local, national, and country commercial electrical and construction codes and regulations.

Before rigging/mounting a single fixture or multiple fixtures to any metal truss/structure or placing the fixture(s) on any surface, a professional equipment installer **MUST** be consulted to determine if the metal truss/structure or surface is properly certified to safely hold the combined weight of the fixture(s), clamps, cables, and accessories.

Overhead rigging requires extensive experience, including amongst others calculating working load limits, installation material being used, and periodic safety inspection of all installation material and the fixture. If you lack these qualifications, do not attempt the installation yourself. Improper installation can result in bodily injury.

Fixture(s) should be installed in areas outside walking paths, seating areas, or away from areas where unauthorized personnel might reach the fixture by hand.

NEVER stand directly below the fixture(s) when rigging, removing or servicing.

Overhead fixture installation must always be secured with a secondary safety attachment, such as an appropriately rated safety cable.

Allow approximately 15 minutes for the fixture to cool down before serving.

INSTALLATION GUIDELINES

OMEGA BRACKETS INSTALLATION

Insert the Omega Brackets into the matching holes on the bottom of the fixture. Secure the Omega Brackets to the fixture by turning each quick-lock fastener $\frac{1}{4}$ turn clockwise; making sure the fastener is completely locked. Omega Brackets can be installed into the fixture base as illustrated below.



SAFETY CABLE

ALWAYS ATTACH A SAFETY WHENEVER INSTALLING THIS FIXTURE IN A SUSPENDED ENVIRONMENT TO ENSURE THE FIXTURE WILL NOT FALL IF THE CLAMP FAILS.

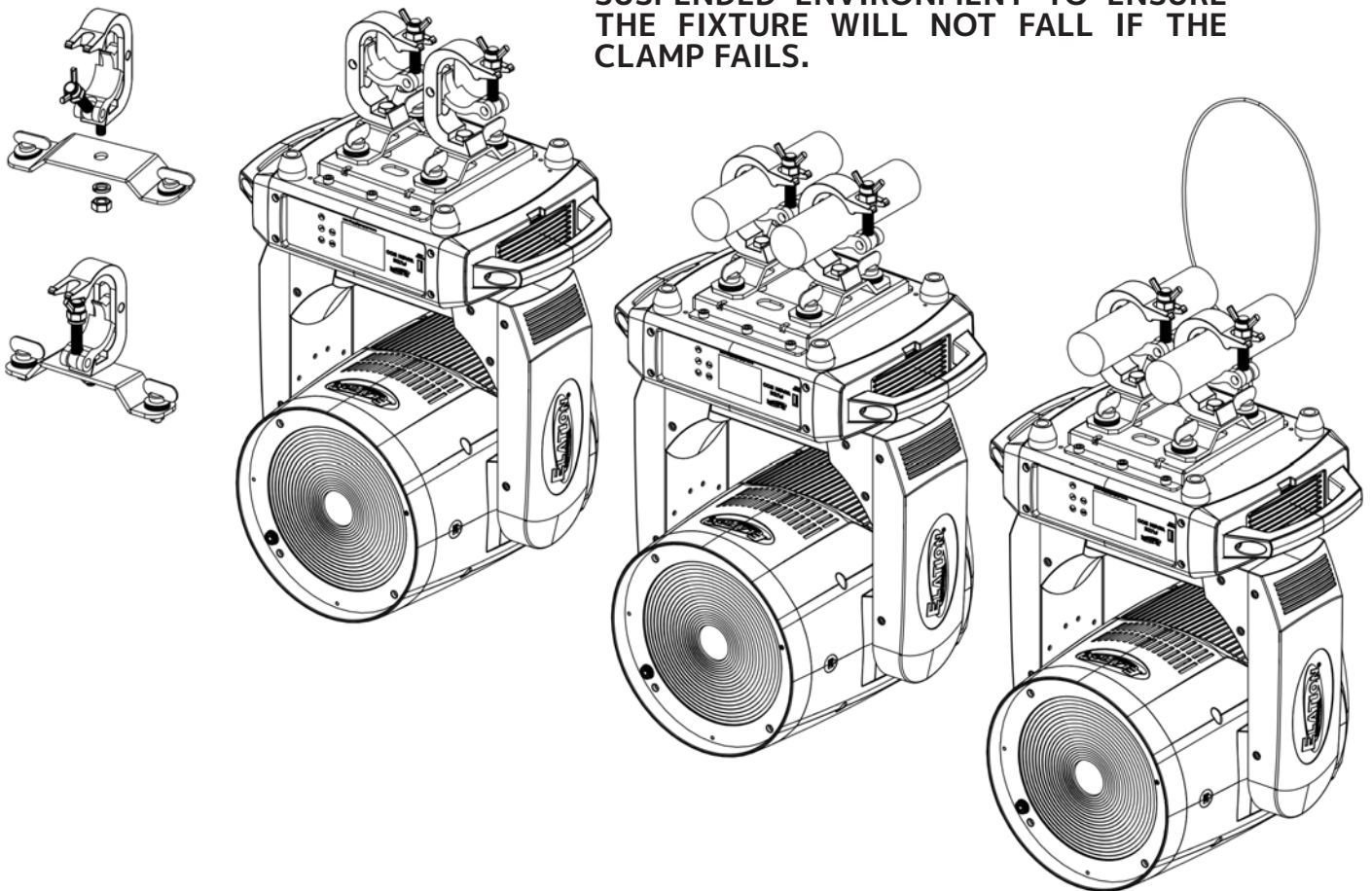

CLAMP INSTALLATION

When mounting fixture to truss, be sure to secure an appropriately rated professional grade rigging clamp to the included **Omega Brackets** using an M10 screw fitted through the center hole of the **Omega Brackets**. The fixture provides built-in rigging points for a **SAFETY CABLE** (not included). Be sure to only use one of the designated rigging points for the safety cable and never secure a safety cable to a carrying handle.

RIGGING

Overhead rigging requires extensive experience, including among others calculating working load limits, installation material being used, and periodic safety inspection of all installation material and the fixture. If you lack these qualifications, do not attempt the installation yourself. Improper installation can result in bodily injury.

INSTALLATION GUIDELINES

FIXTURE INSTALLATION

The Elation Fuze Wash 500 is fully operational in three different mounting positions, hanging upside-down, mounted sideways on trussing, or set on a flat level surface. Be sure this fixture is kept at least 0.2m (7.9in.) away from any flammable materials (decoration etc.). Always use and install the supplied safety cable as a safety measure to prevent accidental damage and/or injury in the event the clamp fails. Never use the carrying handles for secondary attachment.

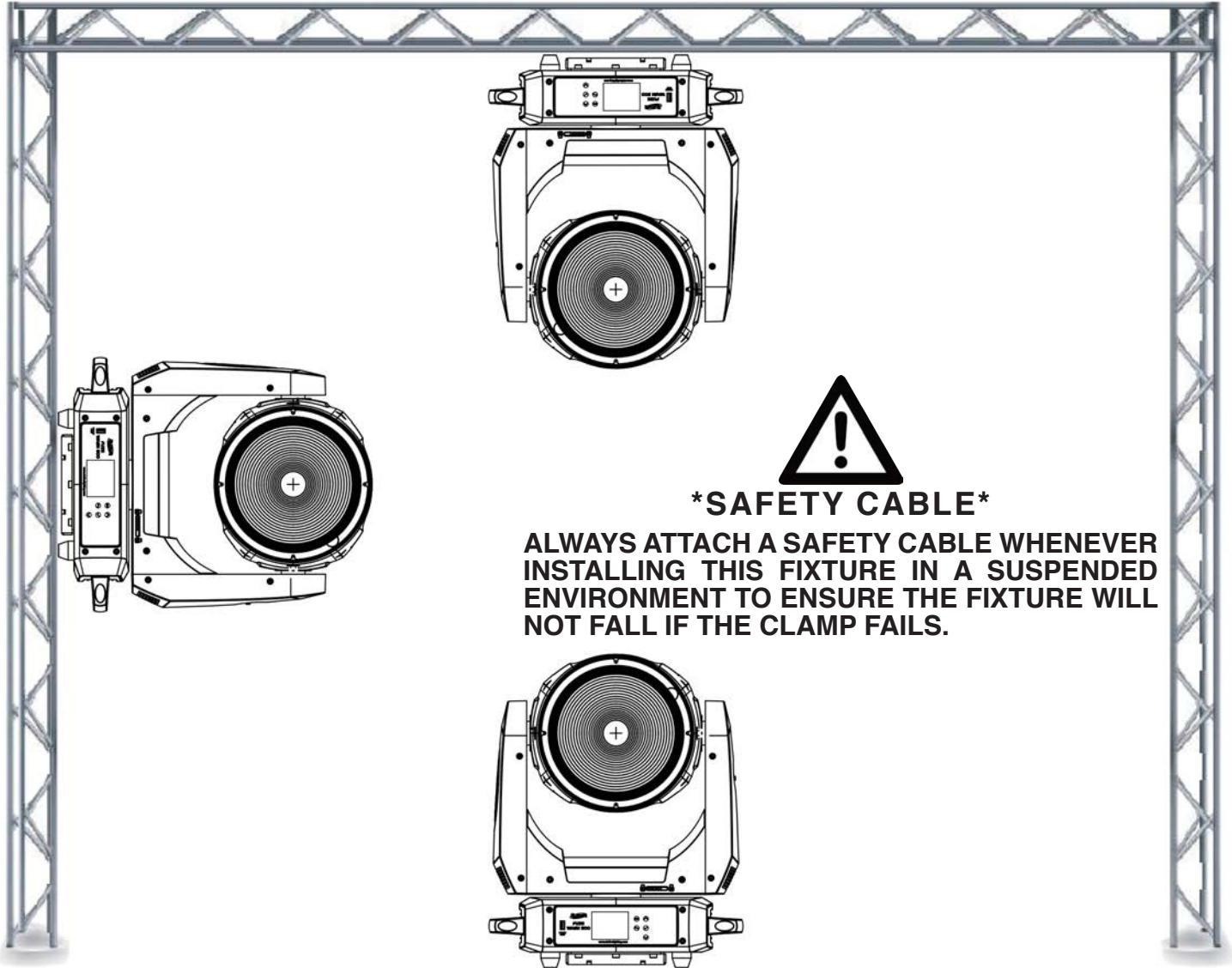

ART-NET | sACN CONNECTION

When connecting fixture to a network switch to control multiple devices, a **Gigabit Ethernet Switch** that supports **IGMP (Internet Group Management Protocol)** is required. Using a **Gigabit Ethernet Switch** that does not support **IGMP** can cause erratic behavior of all connected devices to the switch. Click link below for more information about IGMP.

https://en.wikipedia.org/wiki/Internet_Group_Management_Protocol

INSTALLATION GUIDELINES

POTENTIAL INTERNAL FIXTURE DAMAGE FROM EXTERNAL SOURCES OF LIGHT BEAMS

External sources of light beams from direct sunlight, lighting moving head fixtures, and lasers, which are focused directly towards the exterior housing and/or penetrate the front lens opening of ELATION lighting fixtures, can cause severe internal damage including burning to optics, dichroic color filters, glass and metal gobos, prisms, animation wheels, frost filters, iris, shutters, motors, belts, wiring, discharge lamps, and LEDs.

This issue is not specific only to ELATION lighting fixtures, it is a common issue with lighting fixtures from all manufacturers. Although there is no true way to fully prevent this issue from happening, the guidelines below can prevent any potential damage from occurring if followed. Contact ELATION Service for more details.

DO NOT EXPOSE THE FIXTURE AND/OR FRONT LENS OPENING TO LIGHT BEAMS FROM DIRECT SUNLIGHT, OTHER LIGHTING MOVING HEAD FIXTURES, AND LASERS WHILE UNPACKING, INSTALLATION, USE, AND EXTENDED IDLE TIMES OUTDOORS. DO NOT FOCUS A LIGHT BEAM FROM ONE LIGHTING FIXTURE DIRECTLY TOWARDS ANOTHER.

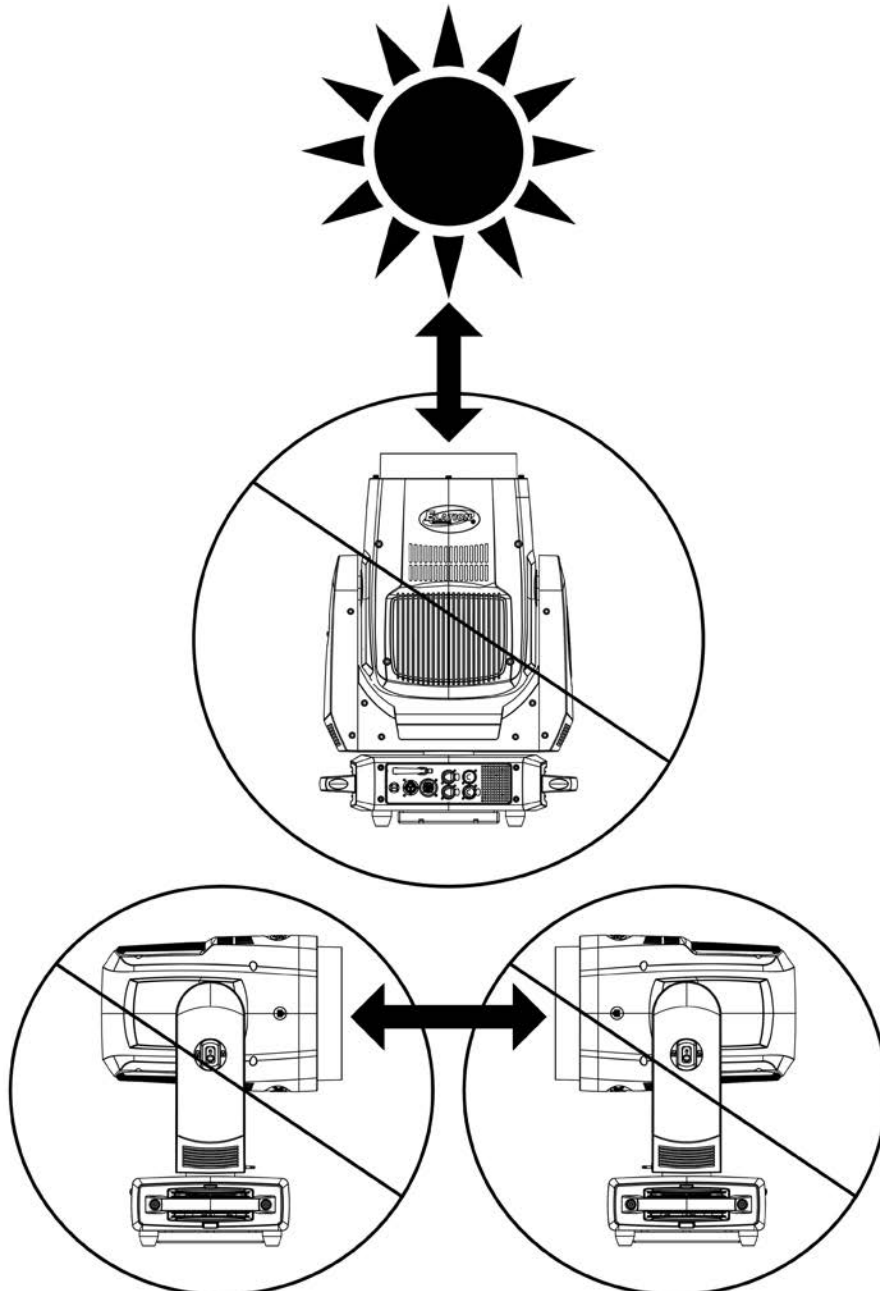

SYSTEM MENU

The fixture includes an easy to navigate system menu. The LCD touch panel display located on the front of the fixture (see image below), provides access to the main system menu and is where all necessary system adjustments are made to the fixture. During normal operation, pressing the **ENTER (Check Mark)** button once will access the fixture's main menu. Once in the main menu you can navigate through the different functions and access the sub-menus with the **UP** and **DOWN** buttons. Once you reach a field that requires adjusting, press the **ENTER** button to activate that field and use the **UP** and **DOWN** buttons to adjust the field. Pressing the **ENTER** button once more will confirm your setting. You may exit the main menu at any time without making any adjustments by pressing the **ESC (Back Arrow)** button.

To access the LCD Menu Control Display via the internal battery, press and hold the **BATTERY ICON** button for 3 seconds. The LCD Menu Control Display will shut **OFF** automatically about 1 minute from the last button press.

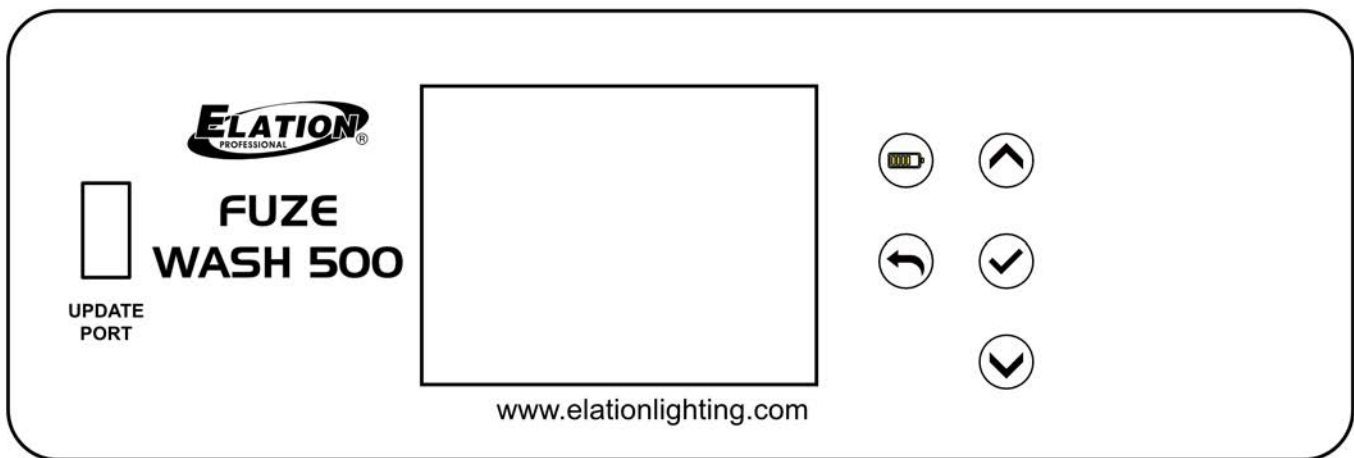

A USB FLASH DRIVE CAN BE USED TO UPDATE THE FIXTURE TO THE LATEST SOFTWARE. Using a USB Flash Drive loaded with the latest software, insert it into the USB Service Port, then navigate to **PERSONALITY/SERVICE**, enter the passcode (050), and select **UPDATE SOFTWARE**. A copy of the latest software can be obtained by contacting Elation Support.



AN ELATION C-LOADER II CAN ALSO BE USED TO UPDATE THE FIXTURE TO THE LATEST SOFTWARE. To order this device, please contact Elation Support for further details.

Detailed instructions can be found online at www.elationlighting.com.

ELATION SERVICE USA - Monday - Friday 8:00am to 4:30pm PST
323-582-3322 | Fax 323-832-9142 | support@elationlighting.com

ELATION SERVICE EUROPE - Monday - Friday 08:30 to 17:00 CET
+31 45 546 85 63 | Fax +31 45 546 85 96 | support@elationlighting.eu

SYSTEM MENU - BARNDOOR MODE

MAIN MENU	OPTIONS / VALUES (Default Settings in BOLD)		
DMX Settings	Dmx Address	001~A XXX	
	DMX Channel Mode	21Ch Standard	
		30CH Extended	
		19CH CMY	
		26CH CMY Ex	
		19CH RGB	
	26CH RGB EX		
No DMX Status	Hold Last		
	Blackout		
	Internal Programs		
Personality	Primary	ON/OFF	
	Secondary	ON/OFF	
	Status	Pan Invert	ON/OFF
		Tilt Invert	ON/OFF
		Pan/Tilt Feedback	ON/OFF
		Pan Degree	630/ 540
		Feedback	ON/OFF
		Pan/TiltSpeed	Slow
		Hibernation	OFF , 01M~99M
	Select Signal	DMX or Aria	
		Aria and DMX Out	
	Aria Settings	Aria Enable	ON/OFF
		Set Aria Channel	0 -14
	Fixure ID	Service PIN	Passcode : 50
		Universe	0
		UnitIPAddr	2.000.000.XXX
		Mask Addr	255.000.000.00
	ProtocolSet	Artnet/sACN	
	KlingNet	OFF/ON	
	Net Switch	OFF/ON	
	Fan Mode	Auto , High, Low, Studio, Mute	
	Zoom Speed	Standard , Fast	
	Dim Modes	Standard , Stage, TV, Architectural, Theatre, Stage 2	
		Dim Speed	0s - 10s (Default = 0.1s)
	Dim Curves	Linear, Square, Square Inverse, S-Curve	
	LED Refresh Rate	900Hz - 1500Hz (Default = 1200Hz), 2500Hz, 4000Hz, 5000Hz, 6000Hz, 10KHz, 15KHz, 20KHz, 25KHz	
	Reset Motors	Reset All Motors	Yes / No
		Pan/Tilt Reset	Yes / No
		Zoom and Beam/Barndoor	Yes / No
	Display	Screen Saver Delay	01M ~10M /OFF
		Touch Screen Lock	OFF/ON
		Rotate Display 180°	YES/NO
Temp Unit	C/F		

SYSTEM MENU - BARNDOOR MODE

MAIN MENU		OPTIONS / VALUES (Default Settings in BOLD)			
Personality (continued)	Service (Passcode = 050)	Calibration	Pan 000 - 255		
			Tilt 000 - 255		
			Red 000 - 255		
			Green 000 - 255		
			Blue 000 - 255		
			Mint 000 - 255		
			Amber 000 - 255		
			CTO Red 000 - 255		
			CTO Green 000 - 255		
			CTO Blue 000 - 255		
			CTO Mint 000 - 255		
			CTO Amber 000 - 255		
			Zoom 000 - 255		
			Beam Shaper 000 - 255		
		USB Software Update	Yes / No		
		Factory Restore	Yes / No		
		Barndoor Record	Yes / No		
Manual Control	Pan	000-255			
	Tilt	000-255			
	Red	000-255			
	Green	000-255			
	Blue	000-255			
	Mint	000-255			
	Amber	000-255			
			
	Control	000-255			
Internal Programs	Program 0	Speed	000-255		
		Fade	000-255		
	Program 1	Speed	000-255		
		Fade	000-255		
	Program 2	Speed	000-255		
		Fade	000-255		
	Program 3	Speed	000-255		
		Fade	000-255		
			
	Program 16	Speed	000-255		
Fade		000-255			
Information	Fixture Life Time	Power On Time	xxxxxx Hours		
	Fixture Last Run Time	Power On Resettable Time	xxxxxx Hours		
		Power On Time Reset	Passcode	YES / NO	
	Fixture Temperatures	LED's	Current	xxx F / xxx C	
			Max Resettable	xxx F / xxx C	
			Max Not Resettable	xxx F / xxx C	
		Reset LED Temp	Passcode	YES / NO	
		Base Temp	Current	xxx F / xxx C	
	Fan Info.	LED_fan RPM	1_fan xxxx		
			2_fan xxxx		
		Base_fan RPM	Base_fan1 xxxx		
			Base_fan2 xxxx		

SYSTEM MENU - BARNDOOR MODE

MAIN MENU	OPTIONS / VALUES (Default Settings in BOLD)			
Information (continued)	DMX Values	Pan		
		Tilt		
		...		
		Zoom		
	Product IDs	RDM UID		
	Error Logs	Fixture Errors	List Errors one by one	
		Reset Error Log	Passcode	YES / NO
	Software Version	VX.X.X		

SYSTEM MENU - NO BARNDOOR MODE

MAIN MENU	OPTIONS / VALUES (Default Settings in BOLD)		
DMX Settings	Dmx Address	001 ~AXXX	
	DMX Channel Mode	17Ch Standard	
		28CH Extended	
		15CH CMY	
		22CH CMY Ex	
		15CH RGB	
	22CH RGB EX		
No DMX Status	Hold Last		
	Blackout		
	Internal Programs		
Personality	Primary	ON/OFF	
	Secondary	ON/OFF	
	Status	Pan Invert	ON/OFF
		Tilt Invert	ON/OFF
		Pan/Tilt Feedback	ON/OFF
		Pan Degree	630/ 540
		Feedback	ON/OFF
		Pan/TiltSpeed	Fast/Slow
		Hibernation	OFF , 01M~99M
	Select Signal	DMX or Aria	
		Aria and DMX Out	
	Aria Settings	Aria Enable	ON/OFF
		Set Aria Channel	0 -14
	Fixure ID	Service PIN	Passcode : 50
		Universe	0
		UnitIPAddr	2.000.000.XXX
		Mask Addr	255.000.000.00
	ProtocolSet	Artnet/sACN	
	KlingNet	OFF/ON	
	Net Switch	OFF/ON	
	Fan Mode	Auto , High, Low, Studio, Mute	
	Zoom Speed	Standard , Fast	
	Dim Modes	Standard , Stage, TV, Architectural, Theatre, Stage 2	
		Dim Speed	0s - 10s (Default = 0.1s)
	Dim Curves	Linear, Square, Square Inverse, S-Curve	
	LED Refresh Rate	900Hz - 1500Hz (Default = 1200Hz), 2500Hz, 4000Hz, 5000Hz, 6000Hz, 10KHz, 15KHz, 20KHz, 25KHz	
	Reset Motors	Reset All Motors	Yes / No
		Pan/Tilt Reset	Yes / No
		Zoom and Beam/Barndoor	Yes / No
	Display	Screen Saver Delay	01M ~10M /OFF
Touch Screen Lock		OFF/ON	
Rotate Display 180°		YES/NO	
Temp Unit	C/F		

SYSTEM MENU - NO BARNDOR MODE

MAIN MENU		OPTIONS / VALUES (Default Settings in BOLD)			
Personality (continued)	Service (Passcode = 050)	Calibration	Pan 000 - 255		
			Tilt 000 - 255		
			Red 000 - 255		
			Green 000 - 255		
			Blue 000 - 255		
			Mint 000 - 255		
			Amber 000 - 255		
			CTO Red 000 - 255		
			CTO Green 000 - 255		
			CTO Blue 000 - 255		
			CTO Mint 000 - 255		
			CTO Amber 000 - 255		
			Zoom 000 - 255		
			Beam Shaper 000 - 255		
		USB Software Update	Yes / No		
		Factory Restore	Yes / No		
		Barndoor Record	Yes / No		
Manual Control	Pan	000-255			
	Tilt	000-255			
	Red	000-255			
	Green	000-255			
	Blue	000-255			
	Mint	000-255			
	Amber	000-255			
			
	Control	000-255			
Internal Programs	Program 0	Speed	000-255		
		Fade	000-255		
	Program 1	Speed	000-255		
		Fade	000-255		
	Program 2	Speed	000-255		
		Fade	000-255		
	Program 3	Speed	000-255		
		Fade	000-255		
			
	Program 16	Speed	000-255		
		Fade	000-255		
	Information	Fixture Life Time	Power On Time	xxxxxx Hours	
Fixture Last Run Time		Power On Resetable Time	xxxxxx Hours		
		Power On Time Reset	Passcode	YES / NO	
Fixture Temperatures		LED's	Current	xxx F / xxx C	
			Max Resettable	xxx F / xxx C	
			Max Not Resettable	xxx F / xxx C	
		Reset LED Temp	Passcode	YES / NO	
		Base Temp	Current	xxx F / xxx C	
Fan Info.		LED_fan RPM	1_fan xxxx		
			2_fan xxxx		
		Base_fan RPM	Base_fan1 xxxx		
			Base_fan2 xxxx		

SYSTEM MENU - NO BARNDOR MODE

MAIN MENU	OPTIONS / VALUES (Default Settings in BOLD)			
Information (continued)	DMX Values	Pan		
		Tilt		
		...		
		Zoom		
	Product IDs	RDM UID		
	Error Logs	Fixture Errors	List Errors one by one	
		Reset Error Log	Passcode	YES / NO
Software Version	VX.X.X			

COLOR LED PROGRAMMING GUIDELINES

The fixture utilizes an advanced additive LED light engine that contains Red, Green, Blue, Mint and Amber LED which when combined, provides a brilliant high CRI White. Using a 5-color LED engine allows the fixture to have a wide color gamut which offers robust saturated colors as well as a wide range of pastel and theatrical colors.

Programming a 5-color LED engine is a bit more time consuming than the more common 3-color CMY (Cyan, Yellow, Magenta) or RGB (Red, Blue Green) systems. To help ensure optimal performance of the fixture, it is highly suggested to try out the multiple DMX control modes to understand specifically how they work with color before programming a full show. A couple of suggested modes are listed below.

The **CMY Extended** DMX control mode provides a “natural” color mix which is compatible with color pickers of most lighting consoles and includes 16-bit color control.

The **Extended RGBMA** (Red, Green, Blue, Mint, Amber) DMX control mode provides slightly higher precision color mixes but may require additional time to find the right values for all 5-color LEDs to achieve a specific desired color.

DIMMER MODE

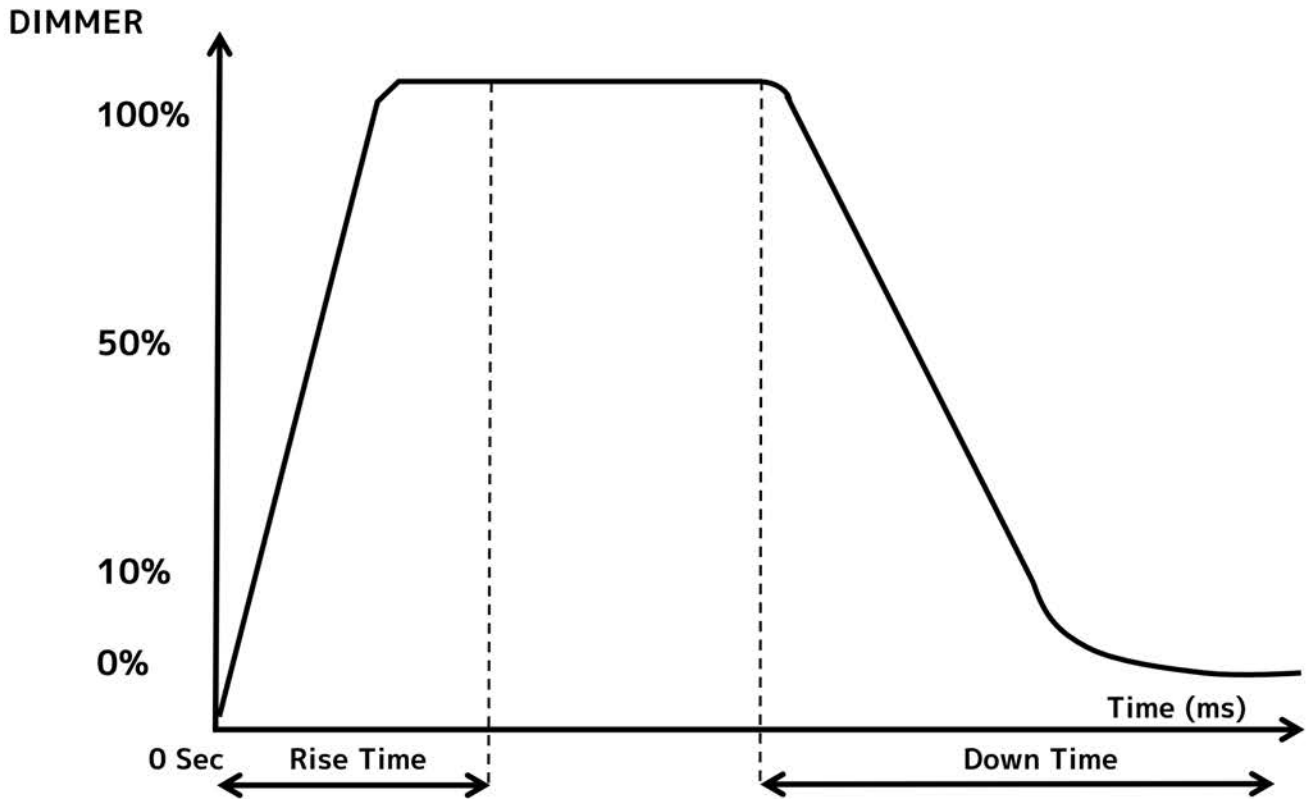

Dimming Curve Ramp Effect	0 sec Fade Time		1 sec Fade Time	
	Rise Time (ms)	Down Time (ms)	Rise Time (ms)	Down Time (ms)
Standard (default)	0	0	0	0
Stage	780	1100	1540	1660
TV	1180	1520	1860	1940
Architectural-	1380	1730	2040	2120
Theatre	1580	1940	2230	2280
Stage 2	0	1100	0	1660

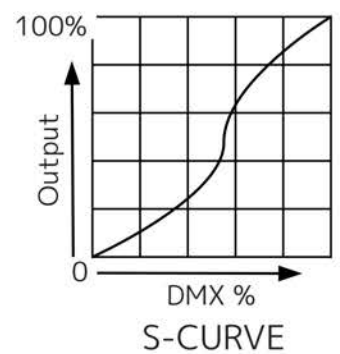
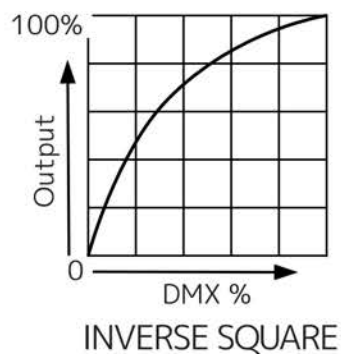
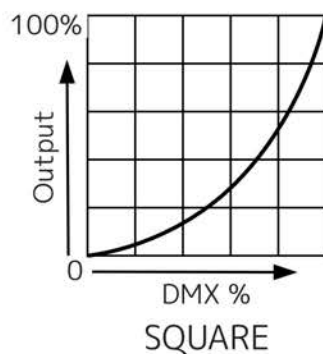
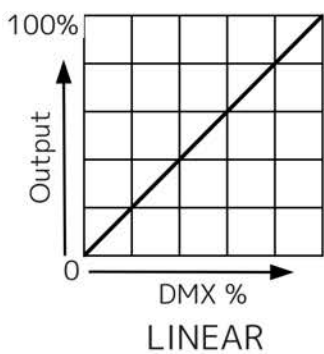

DMX TRAITS - BARNDOOR MODE

Features subject to change without notice

MODE/CHANNEL						VALUE	FUNCTION	DEFAULT	SNAP
Standard	Extended	CMY	CMY Extended	RGB	RGB Extended				
1	1	1	1	1	1	0-255	PAN Movement 8bit: Pan Movement	127	
2	2	2	2	2	2	0-255	Pan Fine 16bit: Fine control of Pan movement	127	
3	3	3	3	3	3	0-255	TILT Movement 8bit: Tilt Movement	127	
4	4	4	4	4	4	0-255	Tilt Fine 16bit: Fine control of Tilt movement	127	
		5	5			0-255	Cyan: Cyan (0-100% Cyan)	0	
			6			0-255	Cyan Fine: Cyan Fine	0	
		6	7			0-255	Magenta: Magenta (0-100% Magenta)	0	
			8			0-255	Magenta Fine: Magenta Fine	0	
		7	9			0-255	Yellow: Yellow (0-100% Yellow)	0	
			10			0-255	Yellow Fine: Yellow Fine	0	
5	5			5	5	0-255	Red: Red (0-100% Red)	255	
	6				6	0-255	Red Fine: Red Fine	255	
6	7			6	7	0-255	Green: Green (0-100% Green)	255	
	8				8	0-255	Green Fine: Green Fine	255	
7	9			7	9	0-255	Blue: Blue (0-100% Blue)	255	
	10				10	0-255	Blue Fine: Blue Fine	255	
8	11					0-255	Mint: Mint (0-100% Mint)	255	
	12					0-255	Mint Fine: Mint Fine	255	
9	13					0-255	Amber: Amber (0-100% Amber)	255	
	14					0-255	Amber Fine: Amber Fine	255	
10	15	8	11	8	11	0-23	CTO: Open	0	
						24 -85	CTO 2400K-8500K (see separate sheet)		
						86-255	8500K		
11	16	9	12	9	12	0	Color Wheel: Open	0	
						1-60	Virtual Swatch Book (see separate sheet)		
						61-179	Open		
							Color Scroll		
						180-201	Clockwise,fast →slow		
						202-207	Stop		
						208-229	Counter-clockwise,slow →fast		
						230-234	Open		
							Random Slots		
						235-239	Fast		
						240-244	Medium		
						245-249	Slow		
						250-255	Open		

DMX TRAITS - BARNDOOR MODE

Features subject to change without notice									
MODE/CHANNEL						VALUE	FUNCTION	DEFAULT	SNAP
Standard	Extended	CMY	CMY Extended	RGB	RGB Extended				
	17		13		13	0	Green Shift: Idle	0	
						1-127	Full Minus Green to Neutral		
						128	Neutral White		
						129-255	Neutral to Full Plus Green		
	18		14		14	0	CTC Crossfade CTO	0	
						1-254	CTO fade to Color Mix		
						255	Color Mix		
12	19	10	15	10	15	0-255	Zoom: Zoom adjustment Narrow - Wide	127	
13	20	11	16	11	16	0-31	Shutter, strobe: Shutter closed	50	X
						32-63	No function (shutter open)		
						64-95	Strobe effect slow to fast		
						96-127	No function (shutter open)		
						128-159	Pulse-effect in sequences		
						160-191	No function (shutter open)		
						192-223	Random strobe effect slow to fast		
						224-255	No function (shutter open)		
14	21	12	17	12	17	0-255	Dimmer: Intensity 0 to 100%	0	
15	22	13	18	13	18	0-255	Dimmer Fine: Dimmer fine	0	
	23		19		19	0-20	Dim Modes Standard	0	X
						21-40	Stage		
						41-60	TV		
						61-80	Architectural		
						81-100	Theatre		
						101-120	Stage 2		
						121	Dimmer Delay Time 0s		
						122	0.1s		
						123	0.2s		
						124	0.3s		
						125	0.4s		
						126	0.5s		
						127	0.6s		
						128	0.7s		
						129	0.8s		
						130	0.9s		
						131	1.0s		
						132	1.5s		
						133	2.0s		
						134	3.0s		
						135	4.0s		
						136	5.0s		
						137	6.0s		
						138	7.0s		
						139	8.0s		
						140	9.0s		
						141	10s		
						142-255	Idle		

DMX TRAITS - BARNDOOR MODE

Features subject to change without notice									
MODE/CHANNEL						VALUE	FUNCTION	DEFAULT	SNAP
Standard	Extended	CMY	CMY Extended	RGB	RGB Extended				
16	24	14	20	14	20	0-255	Barndoor Top Open to Close	0	
17	25	15	21	15	21	0-255	Barndoor Bottom Open to Close	0	
18	26	16	22	16	22	0-255	Barndoor Left Open to Close	0	
19	27	17	23	17	23	0-255	Barndoor Right Open to Close	0	
20	28	18	24	18	24	0-255	Barndoor Index: Min - Max	127	
	29		25		25	0-225	Pan / Tilt and Color Speed: Max to min speed	0	X
						226-235	Blackout by movement		
						236-245	Blackout by all wheel changing		
						246-255	No function		
21	30	19	26	20	26	0-43	Control: Idle	0	X
						40-44	Low Noise - Mute		
						45-49	Low Noise - Studio		
						50-59	Fan Control - Low		
						60-69	Fan Control - High		
						70-79	Fan Control - Auto (Default)		
						80-84	All motor reset		
						85-87	Pan / Tilt reset		
						88-93	Idle		
						94-96	Zoom reset		
						97-99	Accessory Reset		
						100-168	Refresh Rate (Hz)		
						100	900		
						101	910		
						102	920		
						103	930		
						104	940		
						105	950		
						106	960		
						107	970		
						108	980		
						109	990		
						110	1000		
						111	1010		
						112	1020		
						113	1030		
						114	1040		
						115	1050		
						116	1060		
						117	1070		
						118	1080		
						119	1090		
						120	1100		
						121	1110		
						122	1120		
						123	1130		
						124	1140		
						125	1150		

DMX TRAITS - BARNDOOR MODE

Features subject to change without notice									
MODE/CHANNEL						VALUE	FUNCTION	DEFAULT	SNAP
Standard	Extended	CMY	CMY Extended	RGB	RGB Extended				
						126	1160		
						127	1170		
						128	1180		
						129	1190		
						130	1200		
						131	1210		
						132	1220		
						133	1230		
						134	1240		
						135	1250		
						136	1260		
						137	1270		
						138	1280		
						139	1290		
						140	1300		
						141	1310		
						142	1320		
						143	1330		
						144	1340		
						145	1350		
						146	1360		
						147	1370		
						148	1380		
						149	1390		
						150	1400		
						151	1410		
21	30	19	26	20	26	152	1420	0	X
						153	1430		
						154	1440		
						155	1450		
						156	1460		
						157	1470		
						158	1480		
						159	1490		
						160	1500		
						161	2500		
						162	4000		
						163	5000		
						164	6000		
						165	10000		
						166	15000		
						167	20000		
						168	25000		
						169-170	Pan Tilt Speed Slow		
						171-172	Pan Tilt Speed Fast (default)		
						173-174	Zoom Speed Slow		
						175-176	Zoom Speed Fast (default)		
						177-200	Idle		
						201-210	Dimmer Curve Linear		
						211-220	Dimmer Curve Square		
						221-230	Dimmer Curve Inverse Square		
						231-240	Dimmer Curve S-Curve (default)		
						241-255	Idle		

DMX TRAITS - NO BARNDOR MODE

Features subject to change without notice

MODE/CHANNEL						VALUE	FUNCTION	DEFAULT	SNAP
Standard	Extended	CMY	CMY Extended	RGB	RGB Extended				
1	1	1	1	1	1	0-255	PAN Movement 8bit: Pan Movement	127	
2	2	2	2	2	2	0-255	Pan Fine 16bit: Fine control of Pan movement	127	
3	3	3	3	3	3	0-255	TILT Movement 8bit: Tilt Movement	127	
4	4	4	4	4	4	0-255	Tilt Fine 16bit: Fine control of Tilt movement	127	
		5	5			0-255	Cyan: Cyan (0-100% Cyan)	0	
			6			0-255	Cyan Fine: Cyan Fine	0	
		6	7			0-255	Magenta: Magenta (0-100% Magenta)	0	
			8			0-255	Magenta Fine: Magenta Fine	0	
		7	9			0-255	Yellow: Yellow (0-100% Yellow)	0	
			10			0-255	Yellow Fine: Yellow Fine	0	
5	5			5	5	0-255	Red: Red (0-100% Red)	255	
	6				6	0-255	Red Fine: Red Fine	255	
6	7			6	7	0-255	Green: Green (0-100% Green)	255	
	8				8	0-255	Green Fine: Green Fine	255	
7	9			7	9	0-255	Blue: Blue (0-100% Blue)	255	
	10				10	0-255	Blue Fine: Blue Fine	255	
8	11					0-255	Mint: Mint (0-100% Mint)	255	
	12					0-255	Mint Fine: Mint Fine	255	
9	13					0-255	Amber: Amber (0-100% Amber)	255	
	14					0-255	Amber Fine: Amber Fine	255	
10	15	8	11	8	11	0-23	CTO: Open	0	
						24 -85	CTO 2400K-8500K (see separate sheet)		
						86-255	8500K		
11	16	9	12	9	12	0	Color Wheel: Open	0	
						1-60	Virtual Swatch Book (see separate sheet)		
						61-179	Open		
							Color Scroll		
						180-201	Clockwise,fast →slow		
						202-207	Stop		
						208-229	Counter-clockwise,slow →fast		
						230-234	Open		
							Random Slots		
						235-239	Fast		
						240-244	Medium		
						245-249	Slow		
						250-255	Open		

DMX TRAITS - NO BARNDOR MODE

Features subject to change without notice									
MODE/CHANNEL						VALUE	FUNCTION	DEFAULT	SNAP
Standard	Extended	CMY	CMY Extended	RGB	RGB Extended				
	17		13		13	0	Green Shift: Idle	0	
						1-127	Full Minus Green to Neutral		
						128	Neutral White		
						129-255	Neutral to Full Plus Green		
	18		14		14	0	CTC Crossfade CTO	0	
						1-254	CTO fade to Color Mix		
						255	Color Mix		
12	19	10	15	10	15	0-255	Zoom: Zoom adjustment Narrow - Wide	127	
13	20	11	16	11	16	0-31	Shutter, strobe: Shutter closed	50	X
						32-63	No function (shutter open)		
						64-95	Strobe effect slow to fast		
						96-127	No function (shutter open)		
						128-159	Pulse-effect in sequences		
						160-191	No function (shutter open)		
						192-223	Random strobe effect slow to fast		
						224-255	No function (shutter open)		
14	21	12	17	12	17	0-255	Dimmer: Intensity 0 to 100%	0	
15	22	13	18	13	18	0-255	Dimmer Fine: Dimmer fine	0	
	23		19		19	0-20	Dim Modes Standard	0	X
						21-40	Stage		
						41-60	TV		
						61-80	Architectural		
						81-100	Theatre		
						101-120	Stage 2		
							Dimmer Delay Time		
						121	0s		
						122	0.1s		
						123	0.2s		
						124	0.3s		
						125	0.4s		
						126	0.5s		
						127	0.6s		
						128	0.7s		
						129	0.8s		
						130	0.9s		
						131	1.0s		
						132	1.5s		
						133	2.0s		
						134	3.0s		
						135	4.0s		
						136	5.0s		
						137	6.0s		
						138	7.0s		
						139	8.0s		
						140	9.0s		
						141	10s		
						142-255	Idle		

DMX TRAITS - NO BARNDOR MODE

Features subject to change without notice									
MODE/CHANNEL						VALUE	FUNCTION	DEFAULT	SNAP
Standard	Extended	CMY	CMY Extended	RGB	RGB Extended				
16	24	14	20	14	20		Shaper Index	90	
						0-180	0-360 Index		
						181-217	Rotate counter clockwise fast to slow		
						218	Stop		
						219-255	Rotate clockwise slow to fast		
	25		21		21		Pan / Tilt and Color Speed:	0	X
						0-225	Max to min speed		
						226-235	Blackout by movement		
						236-245	Blackout by all wheel changing		
						246-255	No function		
17	26	15	22	15	22		Control:	0	X
						0-43	Idle		
						40-44	Low Noise - Mute		
						45-49	Low Noise - Studio		
						50-59	Fan Control - Low		
						60-69	Fan Control - High		
						70-79	Fan Control - Auto (Default)		
						80-84	All motor reset		
						85-87	Pan / Tilt reset		
						88-93	Idle		
						94-96	Zoom reset		
						97-99	Accessory Reset		
						100-168	Refresh Rate (Hz)		
						100	900		
						101	910		
						102	920		
						103	930		
						104	940		
						105	950		
						106	960		
						107	970		
						108	980		
						109	990		
						110	1000		
						111	1010		
						112	1020		
						113	1030		
114	1040								
115	1050								
116	1060								
117	1070								
118	1080								
119	1090								
120	1100								
121	1110								
122	1120								
123	1130								
124	1140								
125	1150								

DMX TRAITS - NO BARNDOR MODE

Features subject to change without notice									
MODE/CHANNEL						VALUE	FUNCTION	DEFAULT	SNAP
Standard	Extended	CMY	CMY Extended	RGB	RGB Extended				
17	26	15	22	15	22	126	1160	0	X
						127	1170		
						128	1180		
						129	1190		
						130	1200		
						131	1210		
						132	1220		
						133	1230		
						134	1240		
						135	1250		
						136	1260		
						137	1270		
						138	1280		
						139	1290		
						140	1300		
						141	1310		
						142	1320		
						143	1330		
						144	1340		
						145	1350		
						146	1360		
						147	1370		
						148	1380		
						149	1390		
						150	1400		
						151	1410		
						152	1420		
						153	1430		
						154	1440		
						155	1450		
						156	1460		
						157	1470		
						158	1480		
						159	1490		
						160	1500		
						161	2500		
						162	4000		
						163	5000		
						164	6000		
						165	10000		
						166	15000		
167	20000								
168	25000								
169-170	Pan Tilt Speed Slow								
171-172	Pan Tilt Speed Fast (default)								
173-174	Zoom Speed Slow								
175-176	Zoom Speed Fast (default)								
177-200	Idle								
201-210	Dimmer Curve Linear								
211-220	Dimmer Curve Square								
221-230	Dimmer Curve Inverse Square								
231-240	Dimmer Curve S-Curve (default)								
241-255	Idle								

COLOR TEMPERATURE

DMX VALUE	COLOR TEMPERATURE (K)	DMX VALUE	COLOR TEMPERATURE (K)
24	2400	55	5500
25	2500	56	5600
26	2600	57	5700
27	2700	58	5800
28	2800	59	5900
29	2900	60	6000
30	3000	61	6100
31	3100	62	6200
32	3200	63	6300
33	3300	64	6400
34	3400	65	6500
35	3500	66	6600
36	3600	67	6700
37	3700	68	6800
38	3800	69	6900
39	3900	70	7000
40	4000	71	7100
41	4100	72	7200
42	4200	73	7300
43	4300	74	7400
44	4400	75	7500
45	4500	76	7600
46	4600	77	7700
47	4700	78	7800
48	4800	79	7900
49	4900	80	8000
50	5000	81	8100
51	5100	82	8200
52	5200	83	8300
53	5300	84	8400
54	5400	85	8500

VIRTUAL GEL SWATCH BOOK COLORS

Value	Filter Number	Name	Value	Filter Number	Name	Value	Filter Number	Name
1	7	Pale Yellow	21	157	Pink	41	68	Sky Blue
2	103	Straw	22	36	Medium Pink	42	143	Pale Navy Blue
3	151	Gold Tint	23	111	Dark Pink	43	131	Marine Blue
4	100	Spring Yellow	24	128	Bright Pink	44	115	Peacock Blue
5	10	Medium Yellow	25	148	Bright Rose	45	172	Lagoon Blue
6	101	Yellow	26	332	Special Rose Pink	46	116	Medium Blue Green
7	104	Deep Amber	27	793	Vanity Fair	47	90	Dark Yellow Green
8	15	Deep Straw	28	113	Magenta	48	139	Primary Green
9	179	Loving Amber	29	46	Dark Magenta	49	122	Fern Green
10	21	Gold Amber	30	48	Rose Purple	50	89	Moss Green
11	105	Orange	31	126	Mauve	51	124	Dark Green
12	158	Deep Orange	32	49	Medium Purple	52	88	Lime Green
13	22	Dark Amber	33	58	Lavender	53	138	Pale Green
14	778	Millennium Gold	34	199	Palace Blue	54	203	Quarter CT Blue
15	135	Deep Golden Amber	35	119	Dark Blue	55	202	Half CT Blue
16	24	Scarlet	36	132	Medium Blue	56	201	FULL CT Blue
17	106	Primary Red	37	120	Deep Blue	57	200	Double CT Blue
18	26	Bright Red	38	165	Daylight Blue	58	206	Quarter CT Orange
19	27	Medium Red	39	161	Slate Blue	59	205	Half CT Orange
20	19	Fire	40	118	Light Blue	60	204	FULL CT Orange

REMOTE DEVICE MANAGEMENT (RDM)

NOTE: In order for RDM to work properly, RDM enabled equipment must be used throughout the entire system, including DMX data splitters and wireless systems.

Remote Device Management (RDM) is a protocol that sits on top of the DMX512 data standard for lighting, allowing the DMX systems of the device to be managed, modified, and monitored remotely (hence, remote device management). This protocol is ideal for fixtures installed in locations that are not easily accessible.

With RDM, the DMX512 system becomes bi-directional, allowing a compatible RDM enabled controller to send out a signal to devices on the wire, as well as allowing the fixture to respond (known as a GET command). The controller can then use it's SET command to modify settings that would typically have to be changed or viewed directly via the unit's display screen, including the DMX Address, DMX Channel Mode, and Temperature Sensors.

FIXTURE RDM INFORMATION:

RDM Code	Device ID	Device Model ID	Personality ID
0x22A6	0013 0000-FFFF	13	With Barndoor: 21Ch Standard(1); 30CH Extended(2); 19CH CMY(3); 26CH CMY Ex(4); 19CH RGB(5); 26CH RGB EX(6) Without Barndoor: 17Ch Standard(1); 26Ch Extended(2); 15Ch CMY(3); 22Ch CMY Ex(4); 15Ch RGB(5); 22Ch RGB Ex(6)

Please be aware that not all RDM devices support all RDM features, and therefore it is important to check beforehand to ensure that the equipment that you are considering includes all of the features that you require.

The following parameters are accessible in RDM on this device:

[0x0200] Sensor Definition	[0x0602] Pan Tilt Swap
[0x0201] Sensor Value	[0x0500] Display Invert
[0x0080] Device Model Description	[0x0501] Display Level
[0x0081] Manufacturer Label	[0x0603] Realtime Clock
[0x0082] Device Label	[0x1010] Power State
[0x00E0] DMX Personality	[0x1031] Preset Playback
[0x00E1] DMX Personality Description	[0x0122] Default Slot Value
[0x0400] Device Hours	[0x00B0] Language
[0x0015] Comms Status	[0x00A0] Language Capabilities
[0x0031] Status ID Description	[0x00C2] Boot Software Version Label
[0x0032] Clear Status ID	[0x00C1] Boot Software Version ID
[0x0402] Lamp Strikes	[0x0070] Product Detail ID List
[0x0404] Lamp Mode	[0x0030] Status Messages
[0x0405] Device Power Cycles	[0x1001] Reset Device
[0x0600] Pan Invert	[0x0014] Undefined PID [0x0014,(20)]
[0x0601] Tilt Invert	

ERROR CODES

Error Codes subject to change without notice	
ERROR CODES	DESCRIPTION
PAN	Movement is not located in the default position after the reset.
Tilt	These messages will appear after a fixture reset if the magnetic-indexing circuit malfunctions (sensor failed, or magnet is missing) or there is a motor failure (defective motor or a defective motor IC drive on the main PCB). This error may also be displayed if the head/yoke was blocked during a reset function.
Zoom	
Beam Shaper	Movement is not located in the default position after the reset. These messages will appear after a fixture reset if the magnetic-indexing circuit malfunctions (sensor failed, or magnet is missing) or there is a motor failure (defective motor or a defective motor IC drive on the main PCB).
Barndoor	
LED Temp	These messages will appear if there is a temperature and/or fan malfunction.
LED FAN	
BASE FAN	

SPECIFICATIONS

SOURCE

500W 6,500K RGBMA (Red, Green, Blue, Mint, Amber) LED Engine
30,000 Hour Average LED Life*

*Test lab conditions. May vary depending on several factors including but not limited to: Environmental Conditions, Power/Voltage, Usage Patterns (On-Off Cycling), Control, and Dimming.

PHOTOMETRIC DATA

17,000 Total Lumen Fixture Output
CRI 92
Zoom Range 6° - 53°
Field Angle 12.1° - 63.6°
Beam Angle 6.3° - 53.7°

EFFECTS

Motorized Zoom
Optional Indexable Ovalizer Lens
Optional Motorized Barn Doors
Variable 16-bit Dimming Curve Modes
High Speed Electronic Shutter and Strobe

COLOR

RGBMA Color Array
CMY and RGB Emulation
Virtual Color Correction 2400K - 8500K
Green/Magenta Shift
Virtual Gel Swatch Book

CONTROL / CONNECTIONS

DMX Channel Modes
With barndoor: 6 channel modes - 21Ch, 30Ch, 19Ch CMY, 26Ch CMY Ex, 19Ch RGB, 26Ch RGB Ex
Without barndoor: 6 channel modes - 17Ch, 26Ch, 15Ch CMY, 22Ch CMY Ex, 15Ch RGB, 22Ch RGB Ex
16-bit Pan, Tilt, and Dimming Control
DMX Adjustable LED Frequency
DMX, RDM, E-FLY Wireless, Art-Net, sACN Protocol Support
4 Button Touch Control Panel
Full Color 180° Reversible LCD Menu Display
Locking 5pin XLR Connector In/Out
Locking RJ45 Ethernet Connector In/Out
Locking IP65 Power Connector In/Out
USB Connection (Firmware Updates)

SIZE / WEIGHT

Without Snoot:

Length: 13.8" (350mm)
Width: 16.1" (407.9mm)
Vertical Height: 21.7" (550.5mm)

With Snoot:

Length: 15.3" (389.5mm)
Width: 16.1" (407.9mm)
Vertical Height: 21.7" (590mm)
Center Spacing: 23.6" (600mm)
Weight: 40.8 lbs. (18.5kg)

ELECTRICAL / THERMAL

AC 100-240V - 50/60Hz
Max Power Consumption 609W
14°F to 113°F (-10°C to 45°C)
BTU/hr (+/- 10%) 2151.71

APPROVALS / RATINGS

CE | cETLus | IP20 | FCC

Specifications and documentation subject to change without notice.



DIMENSIONS

*Drawings not to scale. Specifications and improvements in the design of this unit and this manual are subject to change without notice.

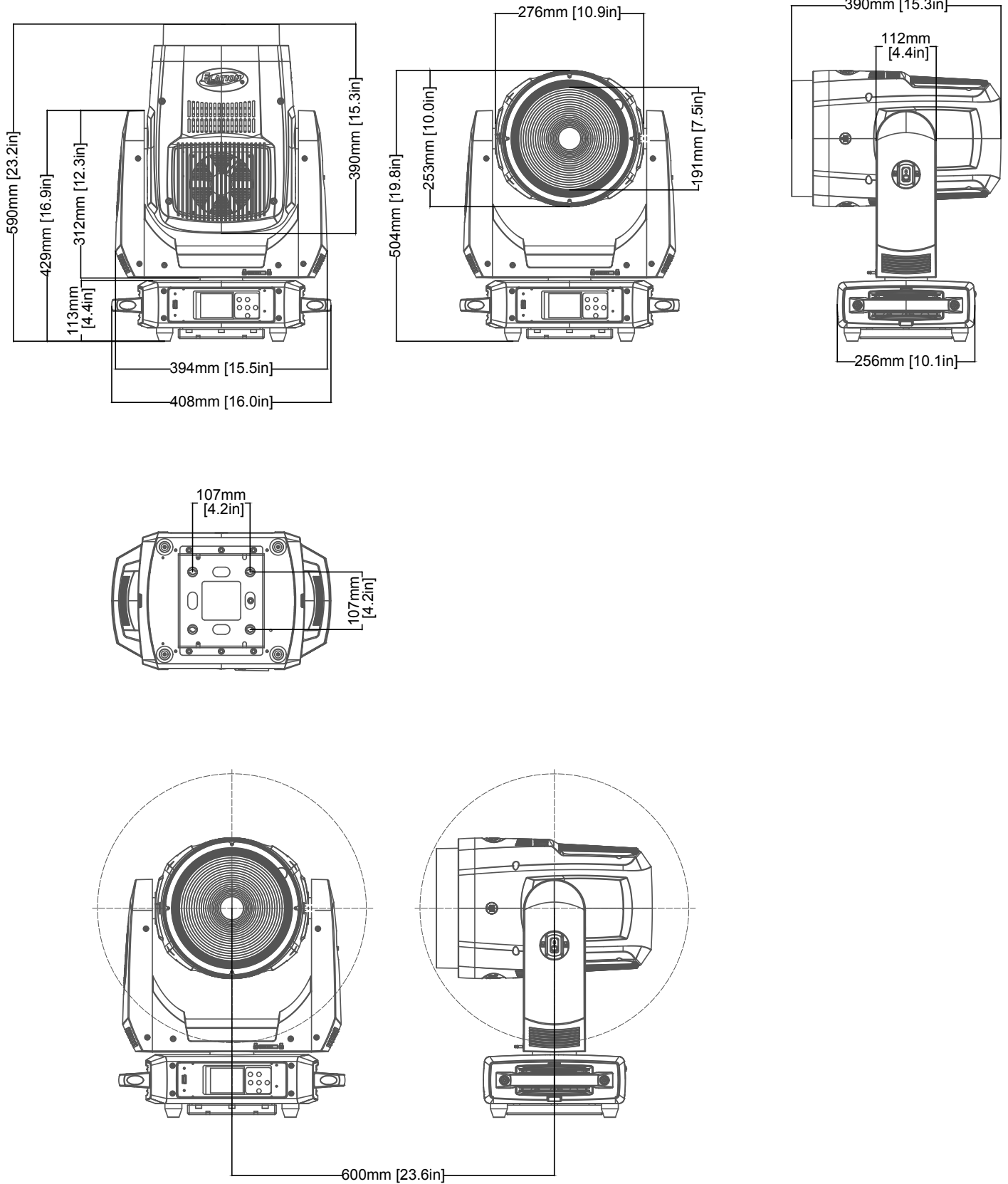

DIMENSIONS

*Drawings not to scale. Specifications and improvements in the design of this unit and this manual are subject to change without notice.

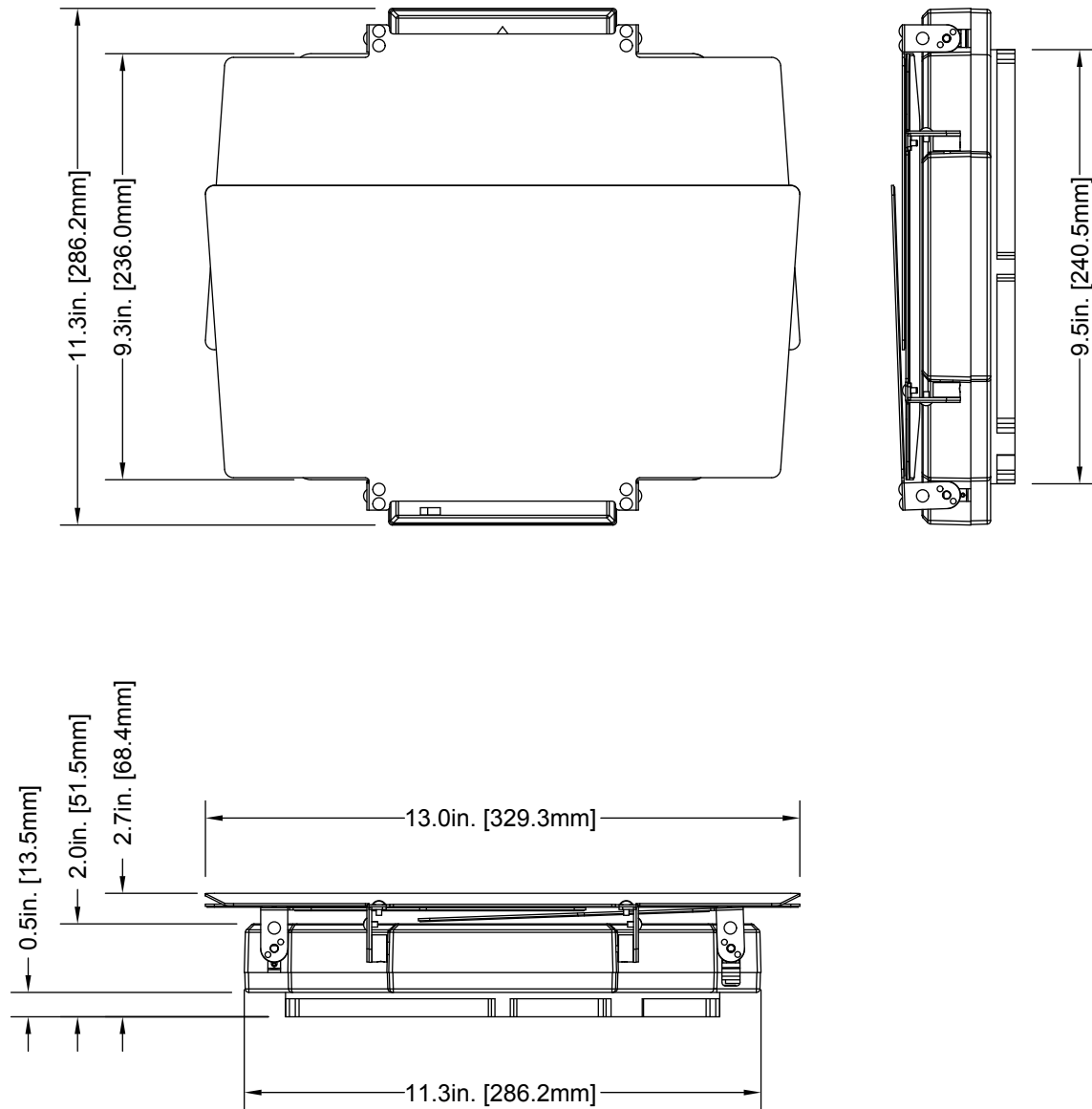

OPTIONAL ACCESSORIES:

ORDER CODE	ITEM
FUZ567WH (USA) 1521000412 (EU)	Elation Fuze Wash 500 WH
TRIGGER CLAMP	Heavy Duty Wrap Around Hook Style Clamp
SIP126	5 ft. (1.5m) IP65 Twist Lock Power Link Cable
AC5PDMX5PRO	5 ft. (1.5m) 5pin PRO DMX Cable
	Additional Cable Lengths Available
8030500064	Beam Shaper
8050000652	Motorized Barn Doors

BARNDOORS, BEAM SHAPER, & SNOOT:

Barn Door (optional) + Beam Shaper (optional) + Snoot (included)

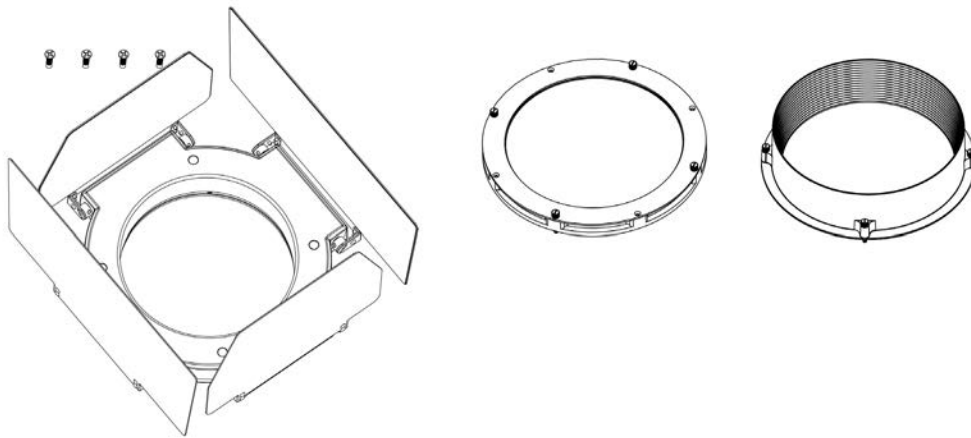

FCC STATEMENT

This device complies with Part 15 of the FCC Rules. Operation is subject to the following two conditions: (1) this device may not cause harmful interference, and (2) this device must accept any interference received, including interference that may cause undesired operation.

FCC RADIO FREQUENCY INTERFERENCE WARNINGS & INSTRUCTIONS

This product has been tested and found to comply with the limits as per Part 15 of the FCC Rules. These limits are designed to provide reasonable protection against harmful interference in a residential installation. This device uses and can radiate radio frequency energy and, if not installed and used in accordance with the included instructions, may cause harmful interference to radio communications. However, there is no guarantee that interference will not occur in a particular installation. If this device does cause harmful interference to radio or television reception, which can be determined by turning the device off and on, the user is encouraged to try to correct the interference by one or more of the following methods:

- Reorient or relocate the device.
- Increase the separation between the device and the receiver.
- Connect the device to an electrical outlet on a circuit different from which the radio receiver is connected.
- Consult the dealer or an experienced radio/TV technician for help.

Energy Saving Matters (EuP 2009/125/EC)

Saving electric energy is a key to help protecting the environment. Please turn off all electrical products when they are not in use. To avoid power consumption in idle mode, disconnect all electrical equipment from power when not in use. Thank you!



This page intentionally left blank.

