

DIGITAL  **PROJECTION**

A Delta Associate Company

E-Vision Laser 9000 Series

High Brightness Digital Video Projector

INSTALLATION & QUICK START GUIDE

CONNECTION GUIDE

OPERATING GUIDE

REFERENCE GUIDE



About this document

Follow the instructions in this manual carefully to ensure safe and long-lasting use of the projector.

Symbols used in this document

Many pages in this document have a dedicated area for notes. The information in that area is accompanied by the following symbols:



LASER WARNING: this symbol indicates that there is a potential hazard of eye exposure to laser radiation unless the instructions are closely followed.



ELECTRICAL WARNING: this symbol indicates that there is a danger of electrical shock unless the instructions are closely followed.



WARNING: this symbol indicates that there is a danger of physical injury to yourself and/or damage to the equipment unless the instructions are closely followed.



NOTE: this symbol indicates that there is some important information that you should read.

Product revision

Because we at Digital Projection continually strive to improve our products, we may change specifications and designs, and add new features without prior notice.

Additional Documentation

Updates to this manual may be available online.

Please use the QR code (also located on the projector) to access the latest E-Vision projector user guides and other documentation via the Digital Projection website.



Or visit the products specification page on the Digital Projection website to download the latest user guide and other documentation.

Legal notice

Trademarks and trade names mentioned in this document remain the property of their respective owners. Digital Projection disclaims any proprietary interest in trademarks and trade names other than its own.

Copyright © 2020 Digital Projection Ltd. All rights reserved.

Notes

Electrical and Physical Specifications

Mains Voltage	100-240VAC 50/60Hz single phase 10.0A
Operating Temperature	0°C to 40°C (32°F to 104°F)
Storage Temperature	-20°C to 60°C (-4°F to 140°F)
Operating Humidity	10% to 85% non-condensing
Storage Humidity	5% to 95% non-condensing
Dimensions	L:525mm (20.6in) X W: 470mm (18.5in) X H 220.5mm (8.6in)
Weight	25Kg (55lb) (projector p/n: 120-481) with lens
Power Consumption	at 100VAC: 1000W typical (normal mode) at 200VAC: 950W typical (normal mode)
Standby Power	< 0.5W (Network Off), < 2W (Network On)
Thermal Dissipation	at 100VAC: 3410BTU/Hour typical (Normal mode) at 200VAC: 3240BTU/Hour typical (Normal mode)
Fan Noise	44dBA typical (Normal mode)

 Specifications are subject to change without notice.

Notes

Optical radiation

Notes

Projector

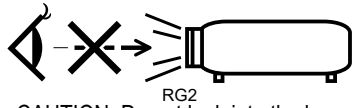

CAUTION: Do not look into the lens

CLASS 3R LASER PRODUCT

This Laser Product is designated as Class 3R during all procedures of operation.

LASER LIGHT - AVOID DIRECT EYE EXPOSURE.

Caution - possibly hazardous optical radiation emitted from this product. Direct or scattered light can be hazardous to eyes and skin.

Do not stare at operating light source.

Do not point laser or allow laser light to be directed or reflected toward other people or reflective objects.

There is a potential hazard of eye exposure to laser radiation if the included instructions are not followed.

Caution – use of controls or adjustments or performance of procedures other than those specified herein may result in hazardous radiation exposure.

Non-laser emission. There remains non-laser emission from the projection lens.

This projector is tested according to IEC/EN62471-5:2015 (Photobiological safety of lamps and lamp systems – Part 5: Image projectors standard) and is Risk Group 2 (low risk).

Remote Control Unit - Presentation Laser Pointer

Caution - possibly hazardous optical Laser radiation emitted from this product.

Class 2 laser product.

Wave Length: 640-660nm. Max Output: less than 1 mW.

Do not stare into the beam.

Do not view directly with optical instruments.

Do not point laser or allow laser light to be directed or reflected towards people, animals, transportation or reflective objects.

Only allow use by responsible persons.

Keep out of reach of children.

This device is not a toy.

Laser information



Caution - use of controls or adjustments or performance of procedures other than those specified herein may result in hazardous radiation exposure.

Location of Laser Aperture

1. The laser aperture is located as indicated below.



Be careful not to expose the eye to direct laser light.

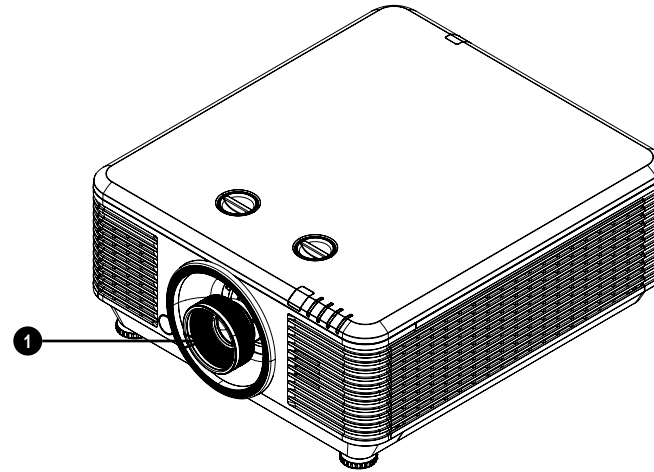

Notes

Laser Parameters

Wavelength	450-460nm (Blue)
Mode of operation	Pulsed, due to frame rate
Pulse duration	1.34ms
Pulse repetition rate	120Hz
Maximum pulse energy	0.698mJ
Total internal power	>100W
Apparent source size	>10mm, at lens stop
Divergence	>100 mili Radian

Laser Pointer Parameters

Wavelength	640-660nm
Max Output	<1mW

Notes

Product Labels

Projector

Notes

DIGITAL PROJECTION DLP Projector / Projecteur (數位投影機 / 數字投影機)

Model Name / Modèle(型號 / 型號): E-Vision Laser 9000-WU ☒
 INPUT / Entrée(輸入 / 輸入) 100-240V ~ 50/60Hz 10.0A

This device complies with Part 15 of the FCC rules, Operation is subject to the following two conditions:
 (1) This device may not cause harmful interference, and
 (2) This device must accept any interference received, including interference that may cause undesired operation.

CAN ICES-3(B) / NMB-3(B).

Caution: Do not open, No user serviceable parts inside.
 警告: 請 勿打開外殼, 設備內無服務性維修之元件。
 警告: 請 勿打開外殼, 設備內無服務性維修之元件。
 Cuidado: no abra la tapa. Ninguna parte interna es reparable por Usuario.
 Avertissement : ne pas ouvrir le couvercle. Le produit ne contient aucune pièce interne réparable par l'utilisateur.

Caution: Do not open, No user serviceable parts inside.
 Laite on liitettävä suojakoskettimilla varustettuun pistorasiaan
 Apparatet må tilkoples jordet stikkontakt
 Apparatet skall anslutas till jordat uttag
 Apparatets stikprop skal tilsluttes en stikkontakt med jord, som giver forbindelse til stikproppens jord



 제품명: 프로젝터
 인증 번호: XXXXXXXXXXXXXXXX
 XXXXXXXXXXXXXXXX
 상호명/제조사: 델타일렉트론시스템
 제조공정/제조국가: Delta Video Display System
 (WUJUNG) Limited / 중국
 A/S 센터: 02-2060-8574
 제조 시기: 201910
 모델명: E-Vision Laser 9000-WU





 R41086
 RoHS

Digital Projection Limited Made in China/製造地:中國/製造地:中國 326xxxxxxXXXXXX XXXXX

Manufacturers ID Label



Laser Aperture Label

Complies with FDA performance standards for laser products except for deviations pursuant to Laser Notice No. 50, dated June 24, 2007

3262314700



LASER RADIATION AVOID DIRECT EYE EXPOSURE
CLASS 3R LASER PRODUCT
 Emitted wavelength : 450-460 nm
 Max. Pulse energy: 0.698 mJ, Pulse duration: 1.34 ms
 激光輻射 避免眼睛受到直接照射 3R類激光產品
 波長: 450-460 nm
 最大脈衝能量: 0.698 mJ, 脈衝時間: 1.34 ms
RAYONNEMENT LASER
EXPOSITION DIRECTE DANGEREUSE POUR LES YEUX
APPAREIL À LASER DE CLASSE 3R
 longueur d'onde : 450-460 nm
 maximum énergie de impulsion : 0.698 mJ,
 durée de impulsion : 1.34 ms
 雷射輻射 避免眼睛受到直接照射 3R類雷射產品
 波長: 450-460 nm
 最大脈衝能量: 0.698 mJ, 脈衝時間: 1.34 ms
 GB 7247.1-2012 / IEC/EN 60825-1:2007
CLASS 1 LASER PRODUCT IEC/EN 60825-1:2014
PRODUIT LASER DE CLASSE 1 IEC/EN 60825-1:2014

Explanatory Label

 E-Vision User Guides
 Follow link for Projector Documentation
 Suivre le lien pour accéder à la documentation du projecteur
 Produktdokumentation finden Sie unter dem Link
 この二次元バーコードをスキャンしてプロジェクターのデータを取得してください
 请扫描条码来取得投影机的文件
 프로젝터 설명서를 보려면 링크를 클릭하십시오

User Guides Label

Remote Control

Notes



Remote Control Label

Label Locations

1. Location of Hazard Warning Symbol and Laser Aperture Label on the body of the projector.
2. Location of Manufacturer's ID Label and Explanatory Label with Certification Statement and Risk Statement on the body of the projector.
3. Location of User Guides Label on the body of the projector.

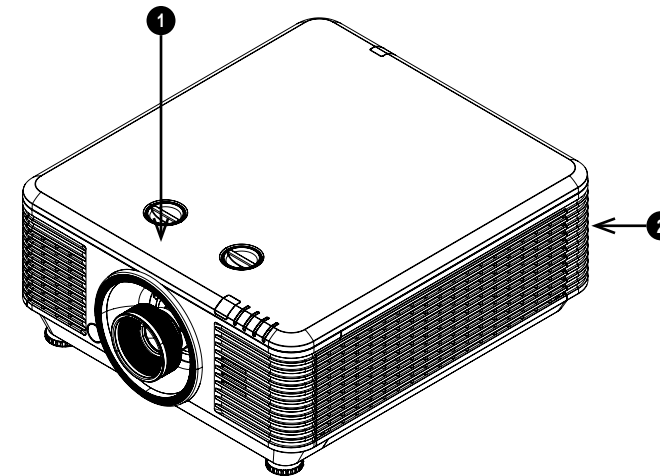
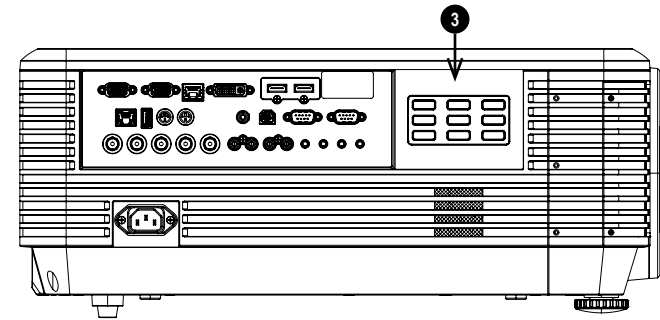

Notes

4. Location of Remote Control Label on the back of the remote.

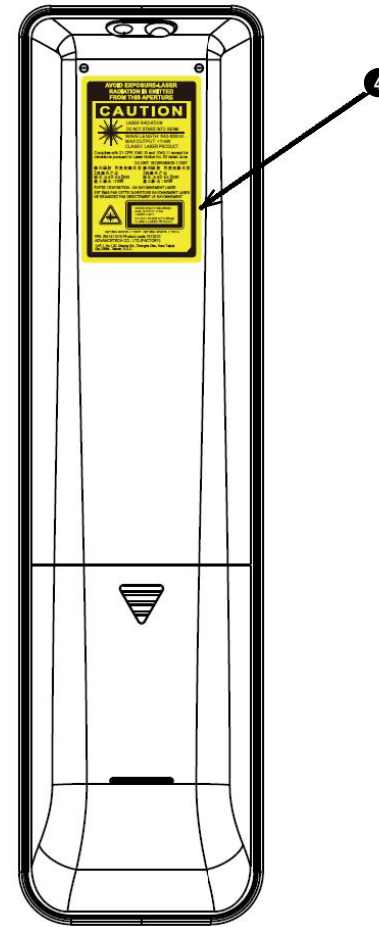

Notes

Interlock Switches

Interlock switches are installed at the main frame, inside the cover. These will power-off the system individually when activated.

1. Will be activated when the projection lens is removed or misplaced.
2. Will be activated when the top cover is removed.

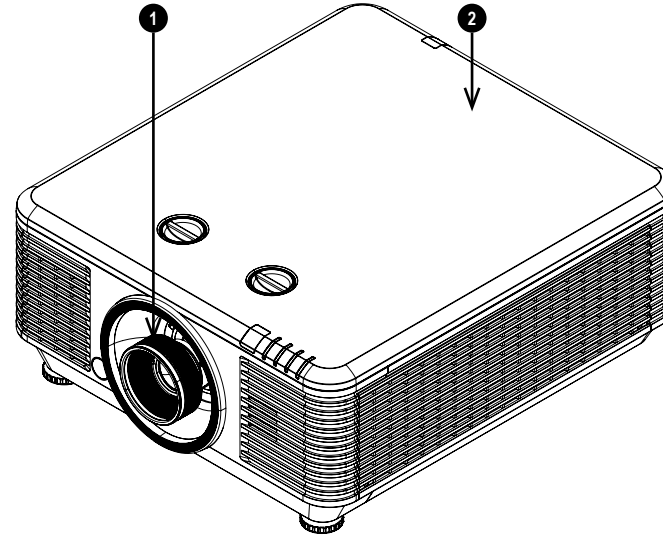

Notes

Introduction

Notes

Congratulations on your purchase of this Digital Projection product. Your projector has the following key features:

- WUXGA native resolution delivering 9,000 ISO lumens.
- Up to 20,000:1 contrast ratio.
- Long life laser light source
- 24/7 Operation
- Rec 709 color gamut capability
- HDR Support
- Support for Frame Sequential, Top and Bottom, Side-By-Side, and Frame Packing 3D.
- HDBaseT® for transmission of uncompressed High Definition Video up to 100 m from the source.
- Cornerstone, Vertical & Horizontal Keystone.
- Control via LAN and RS232.
- Aspect Ratio control.
- Constant brightness mode maintains light output at selected levels.

A serial number is located on the side of the projector. Please record it here for future reference:

Contents

Notes

About this document **2**

Symbols used in this document 2

Product revision 2

Additional Documentation 2

Legal notice 2

Electrical and Physical Specifications **3**

Optical radiation **4**

Projector 4

Remote Control Unit - Presentation Laser Pointer 4

Laser information **5**

Location of Laser Aperture 5

Laser Parameters 6

Laser Pointer Parameters 6

Product Labels **7**

Projector 7

Remote Control 8

Label Locations 9

Interlock Switches **11**

Introduction **12**

Contents **13**

What's in the box? **16**

Connecting the power supply **17**

Projector overview **18**

Control panel **19**

Projector indicators 20

Remote control **21**

Infrared reception 24

Positioning the screen and projector **25**

Roll and pitch 26

Changing the lens **27**

Inserting a new lens 27

Removing the lens 28

Operating the projector **29**

Switching the projector on 29

Switching the projector off 29

Selecting an input signal 29

Selecting a test pattern 29

Adjusting the lens 30

Adjusting the image 30

Orientation 30

Geometry 30

Picture 30

Adjusting the audio 31

Signal inputs **34**

Digital inputs and outputs 34

EDID on the HDMI, and HDBaseT inputs 35

Using HDMI / HDBaseT switchers with the projector 35

Analog inputs and outputs 36

3D connections **37**

3D Sync 38

Control connections **39**

LAN connection examples 40

RS232 connection example 41

Using the menus **44**

Opening the Menu 44

Opening a submenu 44

Exiting menus and closing the OSD 45

Inside the Menu 46

Accessing sub menus 46

Editing projector settings 47

Executing commands 47

Using a slider to set a value 47

Editing numeric values 48

Using the projector **49**

Image Menu 49

Computer 50

Advanced 50

White Balance	51	Diagonal screen sizes	79
Color Manager	51	Positioning the image	80
Color manager parameters explained	52	Aspect ratios explained	82
Dynamic Black Setting	53	Aspect ratios examples	82
HDR Settings	54	Source: 4:3	82
Settings 1 Menu	55	Source: 16:9	83
Keystone	55	Source: 16:10 (native)	83
Keystone settings	56	Aspect ratio example: TheatreScope	84
Keystone example	57	Appendix A: projector indicator messages	85
Audio	57	Appendix B: supported signal input modes	86
Advanced 1	58	2D formats	86
3D Setting	59	3D formats	89
3D types	60	Appendix C: wiring details	90
3D Sync Invert	60	Signal inputs and outputs	90
3D Sync Out Delay	60	HDMI	90
Advanced 2	61	DisplayPort	91
4 Corner	61	HDBaseT input	91
Settings 2 Menu	62	DVI-D input	92
Light Setting	63	VGA input	93
Status	64	Control connections	93
Advanced 1	65	LAN	93
HDBaseT	66	RS232	94
Network	66	Trigger	94
Advanced 2	67	Appendix D: communication parameter setup and Control Protocol	95
Served web pages	68	Operation commands	95
Choosing a lens	72	Appendix E: glossary of terms	104
Basic calculation	73		
Basic calculation example	74		
Full lens calculation	75		
Introducing TRC	75		
Calculating TRC	76		
TRC table	76		
Calculating the throw ratio with TRC	76		
Full lens calculation example	77		
Screen requirements	78		
Fitting the image to the display	78		
WUXGA images displayed full width	78		
WUXGA images displayed with a height of 1200 pixels	78		
WUXGA images displayed full height	79		

DIGITAL 
PROJECTION

A Delta Associate Company

E-Vision Laser 9000 Series

High Brightness Digital Video Projector

INSTALLATION & QUICK START GUIDE



What's in the box?

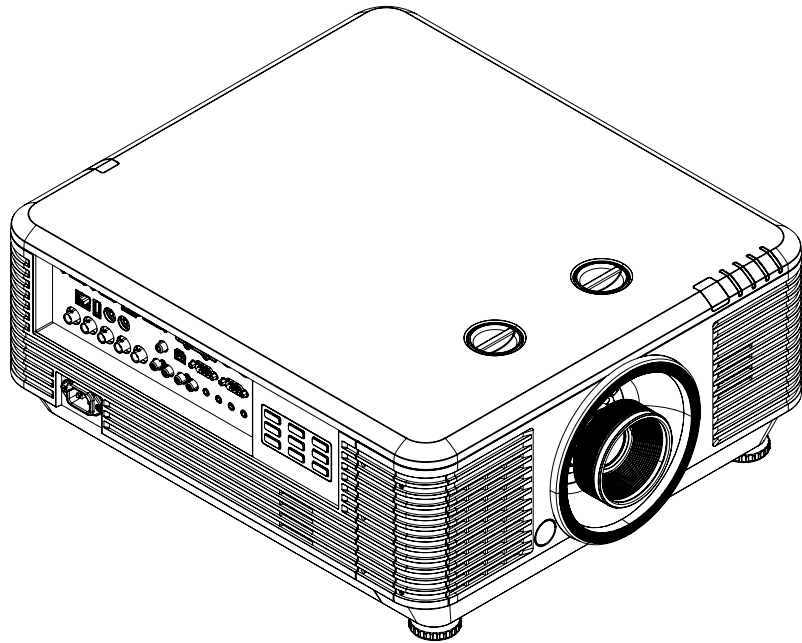

Projector



Remote Control

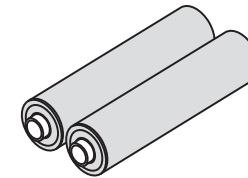

Batteries (2xAAA)

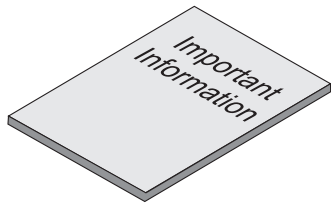

Important Information Book



3 Pin to BNC Adapter Cable

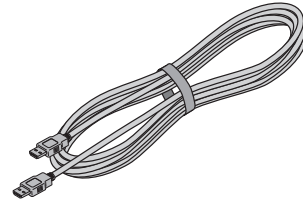

HDMI Cable

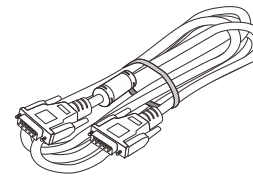

VGA Cable

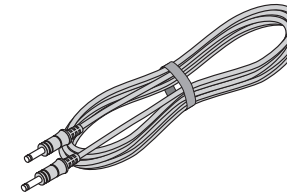

Remote Control Cable

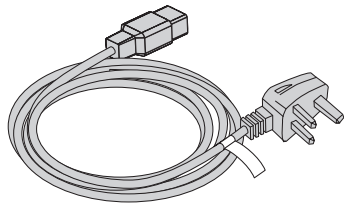

Power Cable, UK

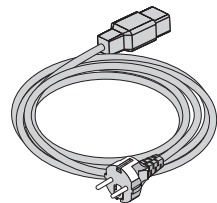

Power Cable, Europe

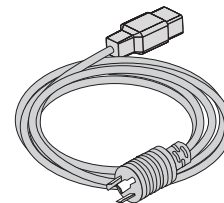



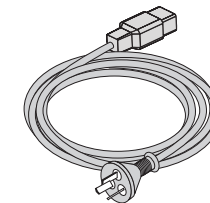

Power Cable, North America



Power Cable, China

Notes

-  *Make sure your box contains everything listed. If any pieces are missing, contact your dealer.*
-  *Only one remote is supplied with the projector.*
-  *Save and store the original box and packing materials, in case you ever need to ship your projector.*
-  *The projector is shipped without a lens.*
-  *Only the appropriate cable for destination territory is supplied with the projector.*

Connecting the power supply

1. Firmly push the mains connector into the AC In socket **1**

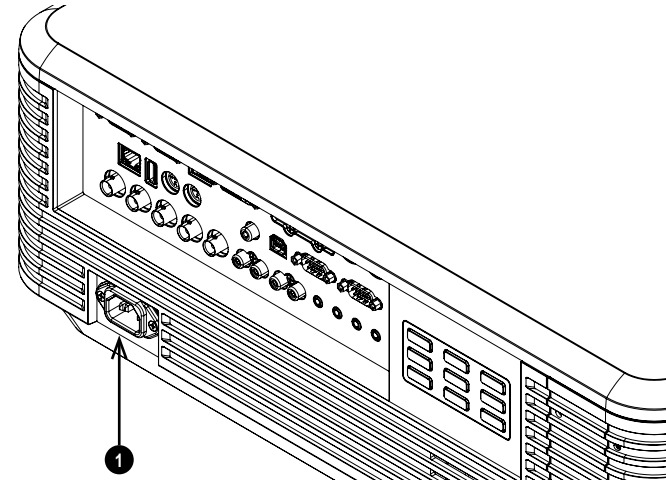

Notes



Use only the power cable provided.



Ensure that the power outlet includes a ground connection as this equipment **MUST** be earthed.



Handle the power cable carefully and avoid sharp bends. Do not use a damaged power cable.



The power indicator will flash green as the projector powers up. It will show solid green when the projector has fully powered up.

Projector overview

1. Air inlet
2. Lens release button
3. Lens mount
4. Horizontal lens shift control
5. Vertical lens shift control
6. Indicators
7. Air inlet
8. Front infrared window
9. Air outlet
10. Rear infrared window
11. Connections panel
12. Control panel
13. Mains socket
14. Adjustable feet

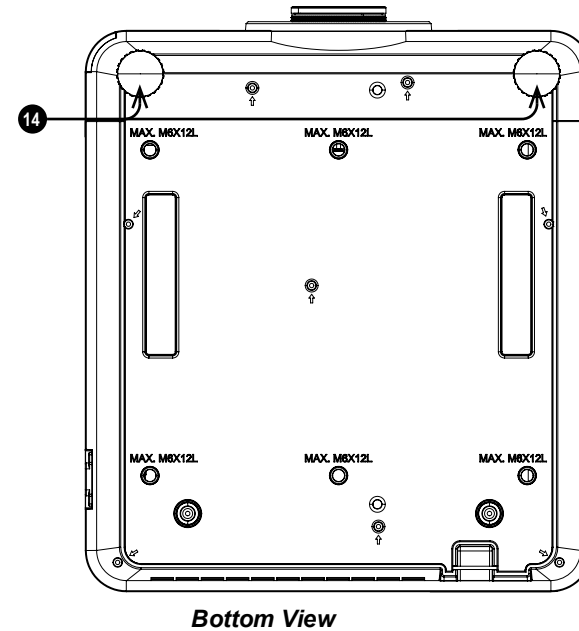
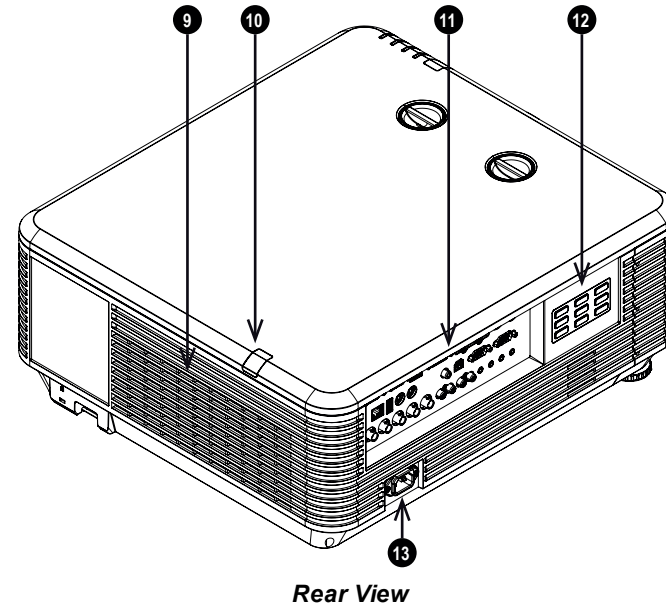
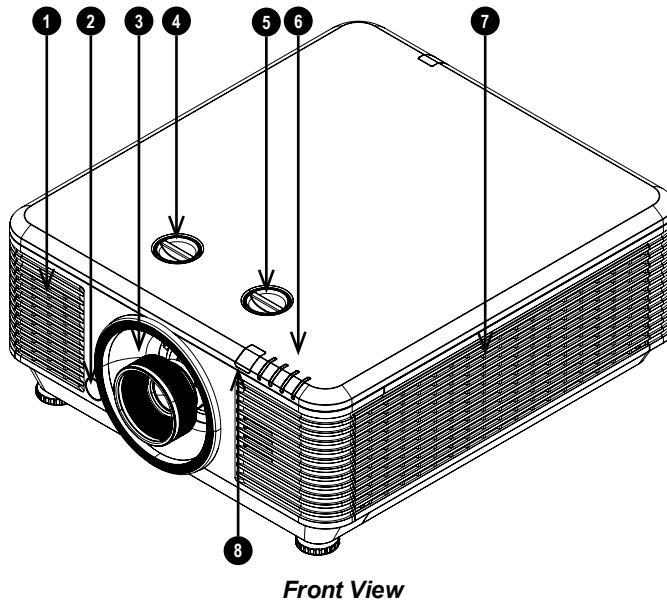

Notes

Control panel

1. **MENU**
Displays and exits the OSD.
2. **Arrow buttons & ENTER**
Navigation buttons used to highlight menu entries in the OSD. Press **ENTER** to open or execute the highlighted menu entry.
Adjusts keystone when OSD is off. Left and right adjust horizontal keystone, up and down adjust vertical keystone.
3. **POWER**
Switches the projector on and off (STANDBY).
4. **SOURCE**
Displays and exits the source menu
5. **AUTO**
Optimizes the image size, position and resolution

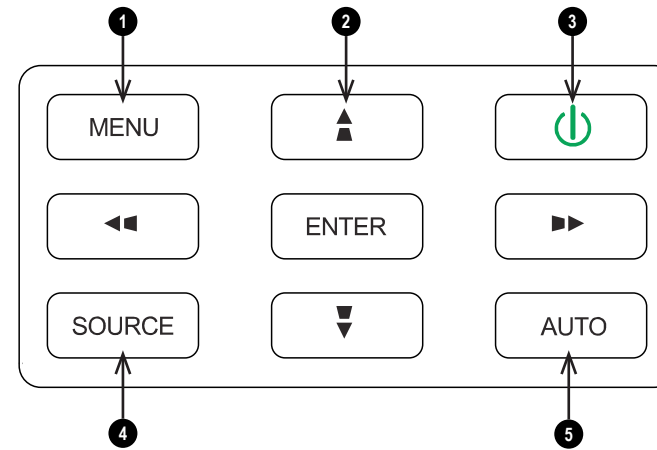

Control Panel

Notes

Projector indicators

- ➊ FILTER On, power indicator on = replace filter
- ➋ TEMP. On = error*
- ➌ LIGHT Flashing sequence = error*
- ➍ POWER On, no additional indicator = light source ready
On, filter indicator on = replace filter
Flashing continuous = starting up or cooling down
Flashing sequence = error*

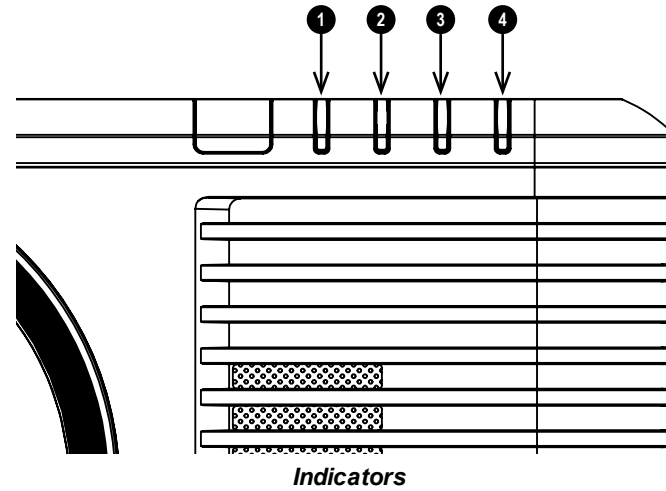

Notes



*See projector indicator messages on page 85

Remote control

1. **Power ON / OFF**
Turns power on and off.
2. **PC**
Select the Computer In input.
3. **HDMI**
Select and toggle the HDMI 1, HDMI 2 or DVI-D input.
4. **USB**
There is no USB function on this projector.
5. **Video S Video**
Select the Video input.
There is no S Video on this projector.
6. **Network**
Open the Network menu in the OSD.
7. **HDBaseT**
Select the HDBaseT input.
8. **MENU**
Access the OSD. If the OSD is open, press this button to go back to the previous menu.
9. **Keystone adjust (arrows)/Navigation (arrows and return)**
Adjust horizontal and vertical keystone.
When the OSD is active, navigate through the menus with the arrows, confirm your choice with the return button.
10. **Keystone**
Open the Keystone menu in the OSD.
11. **EXIT**
Go up one level in the OSD. When the top level is reached, press to close the OSD.
12. **MHL**
Enable the Mobile High-Definition Link technology feature for smart devices.

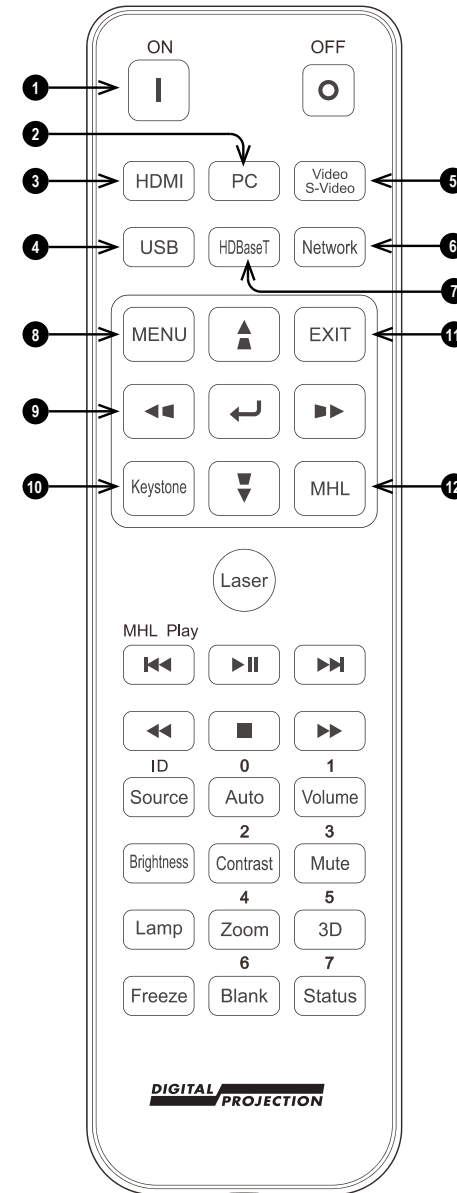

Remote Control

Notes

 This projector does not use the following options on the remote:
USB.
S Video.

 The arrows, return and exit keys can be used to navigate an MHL device, when MHL is enabled.

- 13. **Laser**
Enables the laser pointer.
- 14. **MHL Play controls**
Play, pause, stop, rewind and fast forward MHL content.
- 15. **Auto / ID input 0**
Automatically adjust frequency, phase and position.
Use with **Source / ID** to set the remote ID to 0.
- 16. **Source / ID**
Select the next input source.
Use with a number key to set the remote ID.
- 17. **Volume / ID input 1**
Open the Volume slider.
Use with **Source / ID** to set the remote ID to 1.
- 18. **Contrast / ID input 2**
Open the Contrast slider.
Use with **Source / ID** to set the remote ID to 2.
- 19. **Brightness**
Open the Brightness slider.
- 20. **Mute / ID input 3**
Mute the audio output.
Use with **Source / ID** to set the remote ID to 3.
- 21. **Zoom / ID input 4**
Open the Zoom control.
Use with **Source / ID** to set the remote ID to 4.
- 22. **Lamp**
Open the light source options.
- 23. **3D / ID input 5**
Open the 3D settings menu in the OSD.
Use with **Source / ID** to set the remote ID to 5.

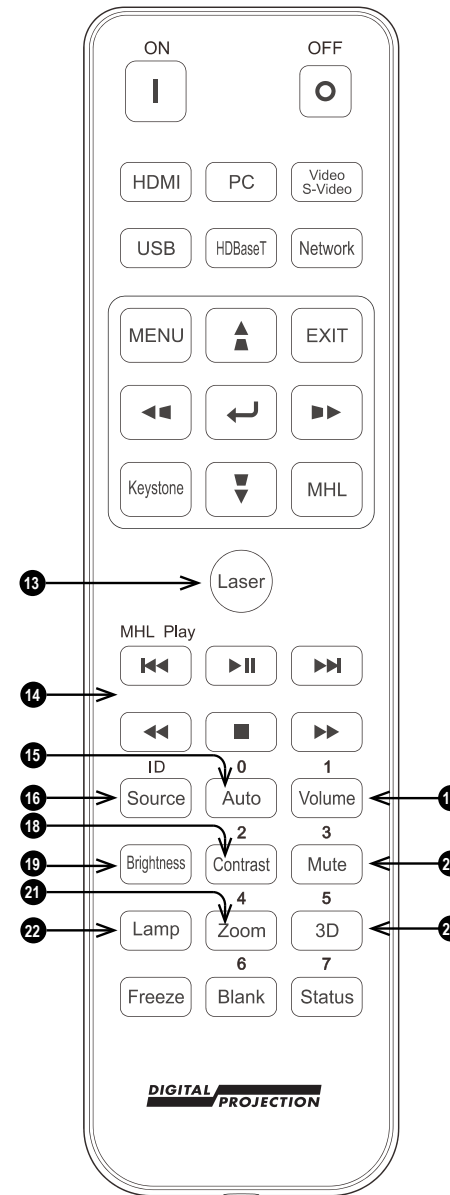

Remote Control

Notes



Do not point the laser pointer towards a persons eyes.

24. Blank / ID input 6

Shows and hides the projected image.

When blanking is enabled, the light source is completely switched off and the screen is blank.

Use with **Source / ID** to set the remote ID to 6.

25. Freeze

Freeze the current frame.

26. Status / ID input 7

Open the Status menu in the OSD.

Use with **Source / ID** to set the remote ID to 7.

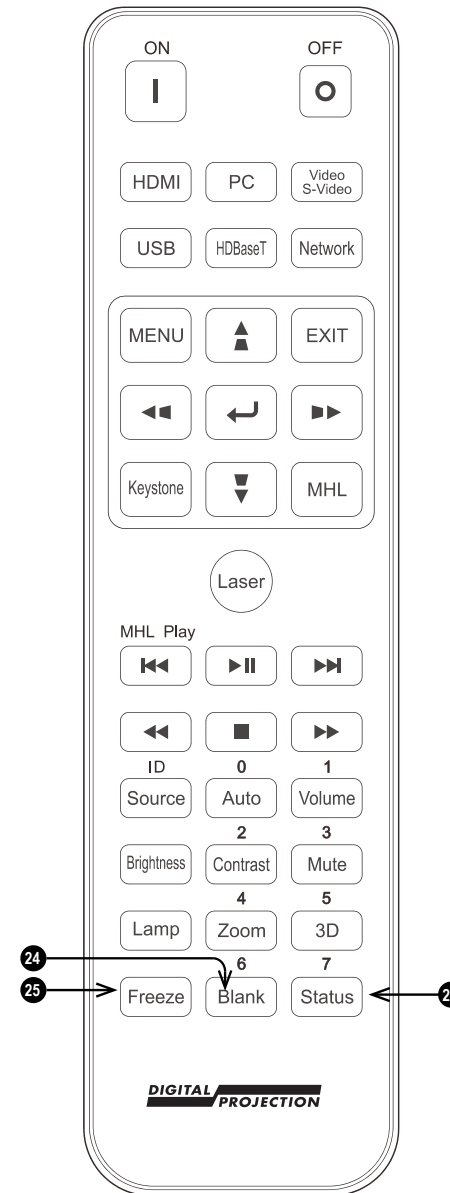
**Remote Control****Notes**

Infrared reception

The projector has infrared sensors at the front and rear.

The remote control uses infrared transmission to control the projector. It is not necessary to point the remote control directly at the projector.

Provided you are not holding the remote perpendicular to the sides or the rear of the projector, the remote will function well within a radius of approximately 7 meters (23 feet) and 15 degrees above or below the projector level.

If the projector does not respond to the remote control, reduce the distance to the projector.

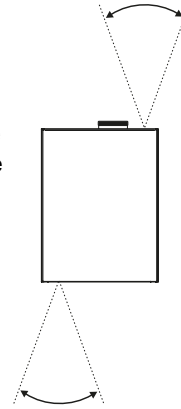

Notes



Avoid using the projector with bright fluorescent lighting turned on. Certain high-frequency fluorescent lights can disrupt the Infrared remote control operation.



Ensure nothing obstructs the path between the remote control and the projector. If the path between the remote control and the projector is obstructed, you can bounce the Infrared signal off certain reflective surfaces such as projector screens.



The buttons and keys on the projector have the same functions as the corresponding buttons on the remote control. This user's manual describes the functions available from the remote control.

Positioning the screen and projector

1. Install the screen, ensuring that it is in the best position for viewing by your audience.
2. Mount the projector, ensuring that it is at a suitable distance from the screen for the image to fill the screen. Set the adjustable feet so that the projector is level, and perpendicular to the screen.

The drawing shows the positions of the feet for table mounting, and the fixing holes for ceiling mounting.

1. Two adjustable feet
2. **Six M6 holes for ceiling mount.** The screws should not penetrate more than 12 mm into the body of the projector.

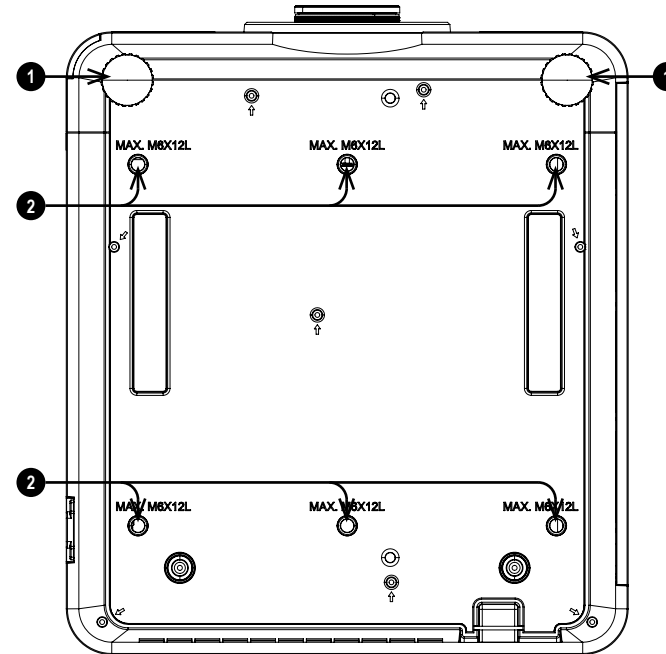

Notes



Always allow the projector to cool for 5 minutes before disconnecting the power or moving the projector.



Ensure that there is at least 50 cm (19.7 in) of space between the ventilation outlets and any wall, and 30 cm (11.8 in) on all other sides.



Do not use the threaded holes for the adjustable feet to hang or mount the projector.

Roll and pitch

The projector can be operated in numerous positions.

In portrait mode, it is recommended to position the projector with inputs facing upward, as shown in the diagram.

1. Recommended positions: inputs side up
2. Also possible.

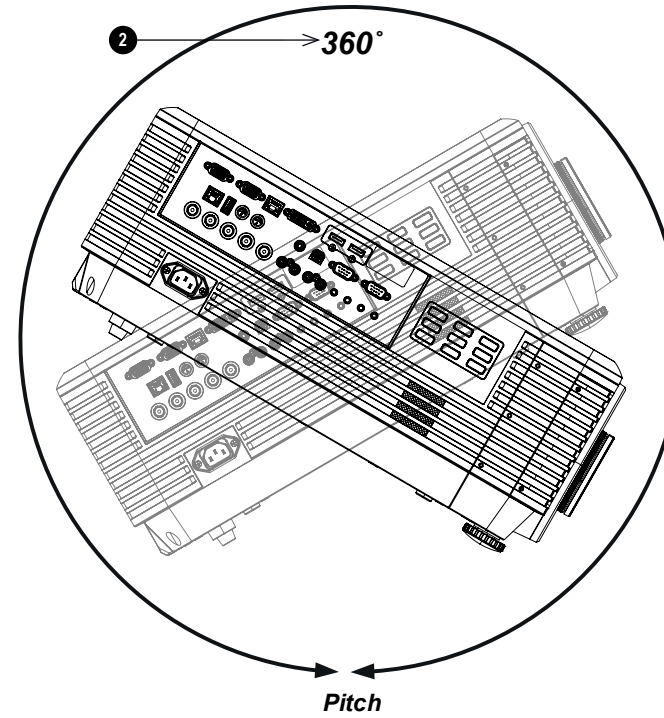
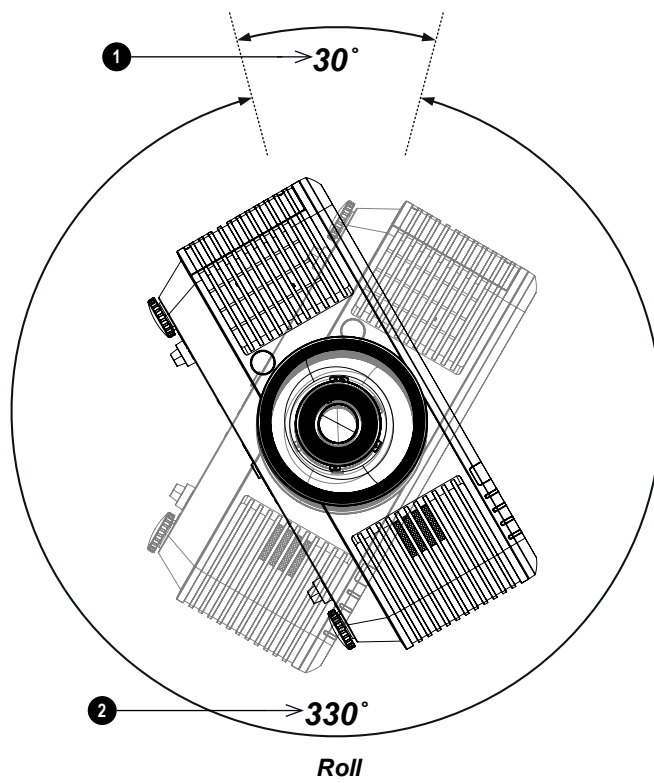

Notes

Changing the lens

Inserting a new lens

1. Remove the lens aperture cap from the projector.

2. Remove the front and rear lens caps from the lens.
3. Position the lens so that the labels are at the top, and gently insert it all the way into the lens mount.
4. Push the lens in firmly and turn it clockwise until it clicks into place.

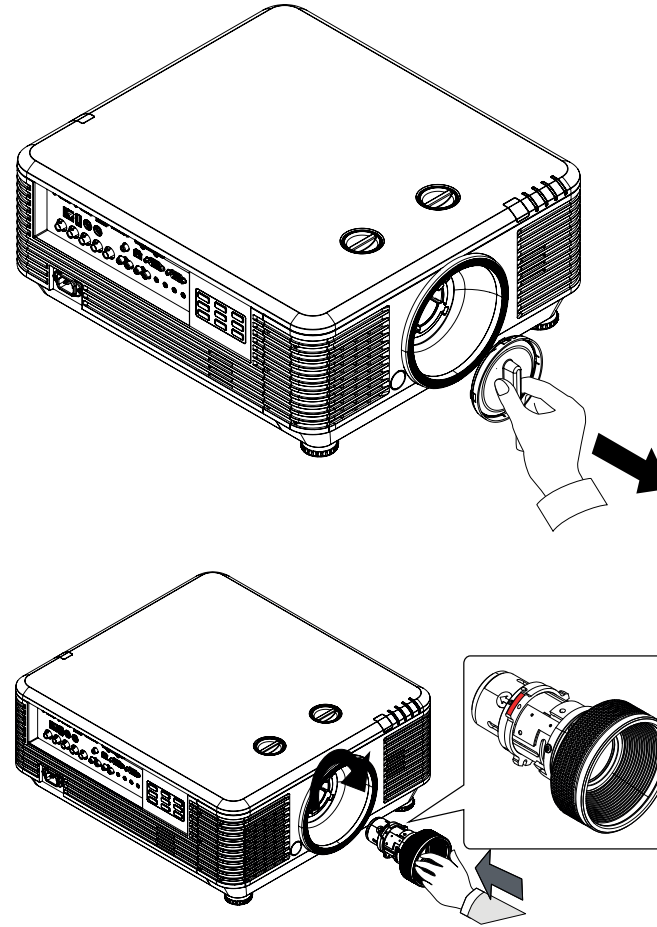

Notes



Before changing the lens, always make sure the projector is switched off and fully disconnected from its power supply.



When changing the lens, avoid using excessive force as this may damage the equipment.



Avoid touching the surface of the lens as this may result in image impairment.



The lens is shipped separately.



Take care to preserve the original lens packaging and protective caps for future use.



The projector will not turn on the light source without a lens fitted

Removing the lens

1. Push the lens release button all the way in
2. Turn the lens anti-clockwise until it disengages
3. Slowly remove the lens.

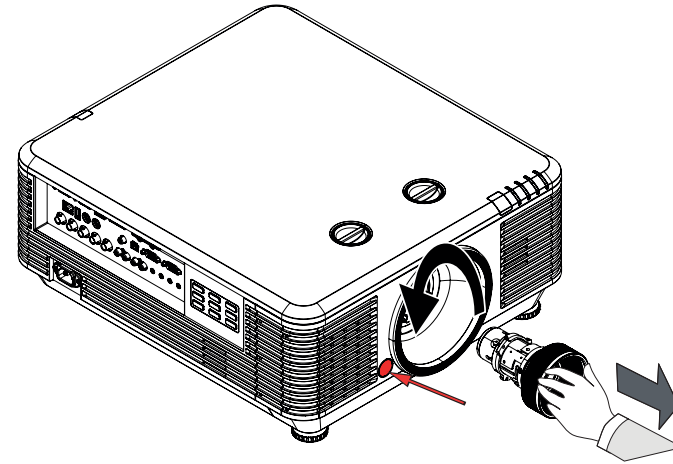

Notes

Operating the projector

Switching the projector on

1. Ensure a lens is fitted. Connect the power cable between the mains supply and the projector.
The **POWER** indicator lights solid green.
2. Press one of the following buttons:
 - On the remote control, the **ON** button
 - On the projector control panel, the **POWER** button.

The **POWER** indicator begins flashing green. When the fans begin working, the flashing stops and the **POWER** indicator shows steady green. The projector is now switched on.

Switching the projector off

1. Press **OFF** on the remote control or **POWER** on the control panel, then press again to confirm your choice.
The **POWER** indicator on the control panel will start flashing green, the light source will go out and the cooling fans will run for a short time. The **POWER** indicator stops flashing green and changes to solid green when the projector enters Standby mode.
2. If you need to switch the projector off completely, wait until the projector enters Standby mode, then disconnect the AC power cable from the projector.

Selecting an input signal

1. Connect one or more image sources to the projector.
2. Select the input you want to display:
 - Press one of the input buttons or the source button on the remote control.
 - Press **MENU** on the remote control or control panel and navigate to the Source setting in the Settings 1 tab, or press **SOURCE** on the control panel. Use the **UP** and **DOWN** navigation buttons to select the input source in the **SOURCE** menu. Press **ENTER** to confirm your choice.

Selecting a test pattern

The following test patterns are available: RGB Ramps, Color Bars, Step Ramps, Check Board, Grid, Horizontal Lines, Vertical Lines, Diagonal Lines, Horizontal Ramp, Vertical Ramp, White, Red, Green, Blue, Black, *None*.

To display a test pattern:

1. Press **MENU** on the remote or control panel to open the OSD.
2. Use the **LEFT** and **RIGHT** arrow buttons to access the **Settings 1** menu.
3. Use the **UP**, **DOWN** and **RETURN** buttons to access the **Advanced 2** sub menu.
4. Highlight **Test Pattern** and select a test pattern using the **LEFT** and **RIGHT** arrow buttons.

To return to the main image, set the test pattern to none and exit the OSD by pressing **EXIT**.

Notes



The first time you use the projector, you can set OSD language from the quick menu. (See Setting the OSD language in the user manual.)



See Connecting the power supply on page 17.



The auto power on feature can be switched off in the Settings 2 menu. See Settings 2 Menu on page 62.



Use only the power cable provided.



Ensure that the power outlet includes a ground connection as this equipment **MUST** be earthed.



Handle the power cable carefully and avoid sharp bends. Do not use a damaged power cable.



See Using the menus on page 44 for full details of how to use the controls and the menu system.

Adjusting the lens

The lens can be adjusted using the controls on the lens and the controls on the body of the projector:

- Use the zoom control **1** on the lens to zoom in or out.
- Use the horizontal shift control **2** and the vertical shift control **3** on the body of the projector to adjust the position of the image on the screen.
- Use the focus control **4** on the lens to focus the image.

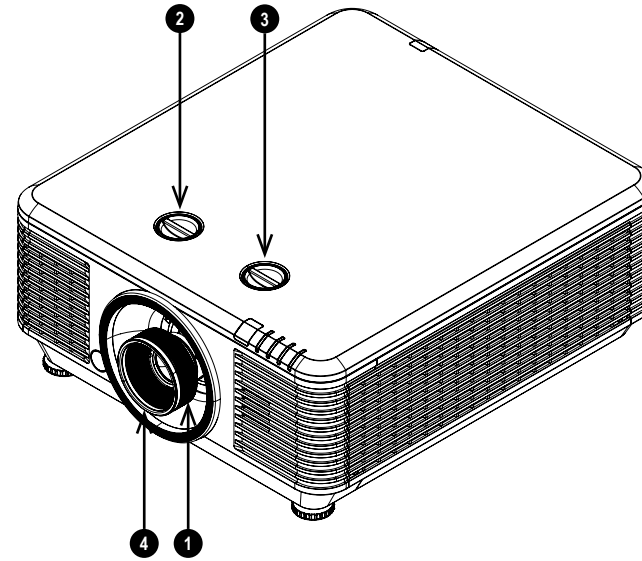

Adjusting the image

Orientation

This can be set from the **Settings 1** menu.

Highlight **Projection** and choose from **Desktop Front**, **Desktop Rear**, **Ceiling Front** and **Ceiling Rear**.

Geometry

Settings such as **Keystone** and **4 Corners** can be set from the **Settings 1** menu.

Picture

Settings such as **Display Modes**, **Brightness**, **Contrast**, **Color Manager** (Hue, Saturation and Gain), **Dynamic Black Settings**, **HDR Settings**, and **Advanced** (Sharpness and Gamma) can be set from the **Image** menu.

Notes

 *Keystone requires an external signal input to enable it to be set.*

 *This product includes a DICOM simulation feature intended for training and other non-medical diagnosis purposes.*

Adjusting the audio

The audio output can be adjusted using the remote control or OSD:

- Use the **Volume** button on the remote to open the volume bar. Use the LEFT and RIGHT arrow buttons to adjust the volume level.
- Use the **Mute** button on the remote to mute the audio.
- Press **MENU** on the remote or control panel to open the OSD. Navigate to the **Settings 1** menu and open the **Audio** sub menu to adjust the audio.

Notes

This page is intentionally left blank

DIGITAL  **PROJECTION**

A Delta Associate Company

E-Vision Laser 9000 Series

High Brightness Digital Video Projector

CONNECTION GUIDE



Signal inputs

Digital inputs and outputs

1. **USB**
USB 5 V / 1.5 A output. Connect a USB cable to supply power to an external device.
2. **HDBaseT**
Receives digital signal from HDBaseT-compliant devices. Connect an HDBaseT cable.
3. **DVI-D**
This input can receive digital signal from a compatible source. Supports sources up to 1920 x 1200 resolution, 24-60 Hz. Supports HDCP.
4. **Service**
This port is for servicing purposes only.
5. **HDMI 1 / HDMI 2**
HDMI 2.0 inputs supporting HDCP 2.2. Connect an **HDMI** cable to the connector.

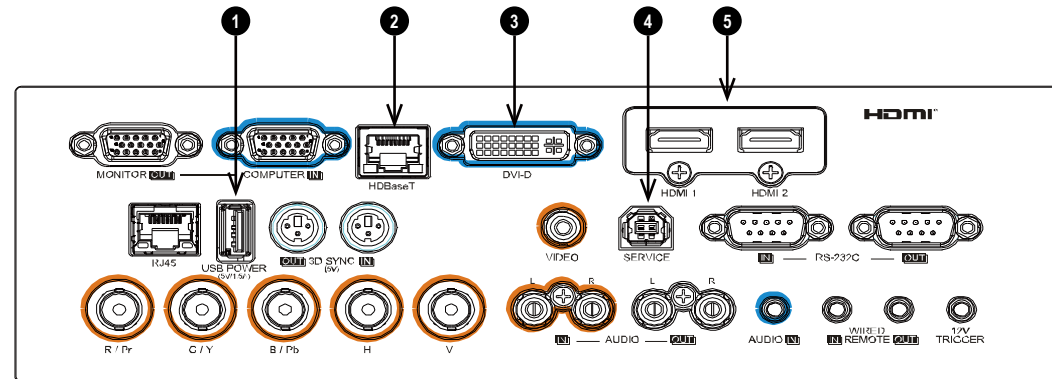

Notes

For simultaneous HDBaseT and LAN connectivity, a third-party distribution product can be utilised to combine HDBaseT video stream with LAN connection for delivery to the projector.

EDID on the HDMI, and HDBaseT inputs

If you are using a computer graphics card or another source that obeys the EDID protocol, the source will automatically configure itself to suit the capability of the projector.

Otherwise refer to the documentation supplied with the source to manually set the resolution to the DMD™ resolution of the projector or the nearest suitable setting. Switch off the source, connect to the projector, then switch the source back on again.

Using HDMI / HDBaseT switchers with the projector

When using a DisplayPort/HDMI/HDBaseT source switcher with the projector, it is important to set the switcher so that it passes the projector EDID through to the source devices.

If this is not done, the projector may not be able to lock to the source or display the source correctly as its video output timings may not be compatible with those of the projector. Sometimes this is called transparent, pass-through or clone mode. See your switcher's manual for information on how to set this mode.

1. Sources
2. Switcher
3. Projector

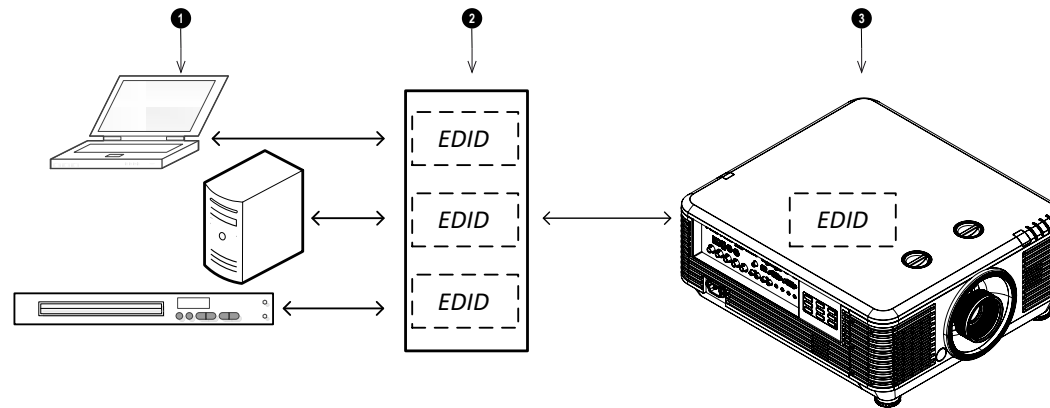

The EDIDs in the switcher should be the same as the one in the projector.

Notes

Analog inputs and outputs

1. Monitor Out

Connect an analog monitor (VGA) cable to the 15-pin D-type to output the signal received on the Computer In input.

2. Computer In

This input receives analog signals from a computer. When using this input, it is best to use a fully wired VGA cable to connect the source to the projector. This will allow the source to determine the projector's capabilities via DDC and show an optimized image. Such cables can be identified as they have a blue connector shell.

3. Video

This input receives analog composite signals.

4. Component

RGBHV, RGsB or RGBS

Set Color Space in the Advanced 2 sub menu of the Settings 2 menu to Auto or RGB-Video.

YPbPr or YCbCr

Set Color Space in the Advanced 2 sub menu of the Settings 2 menu to YUV.

5. L & R Audio In (L+R RCA)

Use this Audio In (L+R RCA) to input audio when the Composite Video input is selected.

6. L & R Audio Out (L+R RCA)

Connect to the left and right RCA Audio Out outputs, to send audio out from the Projector inputs (e.g HDMI, HDBaseT, Audio In) to an external amplifier / speakers.

7. Audio In

Use this Audio In (3.5 mm stereo jack plug) to input audio when the Component (RGBHV, RGsB or RGBS) video input is selected.

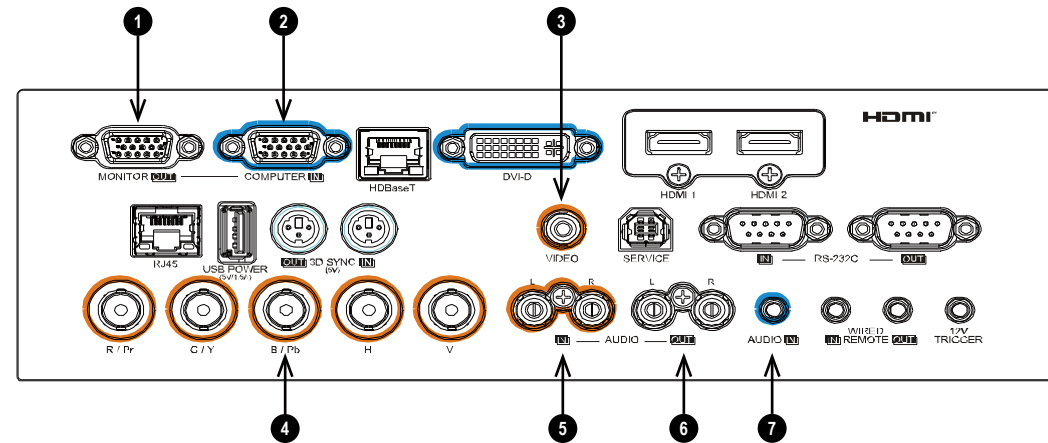

Notes

3D connections

1. 3D Sync In / Out

Sync In is the 3D sync input signal. Connect the 3D sync from your graphics card or server.

Sync Out is the 3D sync output signal. This is affected by settings in the 3D menu such as 3D Sync Out Delay and 3D Sync Output. Connect this to an IR emitter or ZScreen.

2. HDBaseT

Receives 3D signal from HDBaseT-compliant devices. Connect an HDBaseT cable.

3. DVI-D

Single Link DVI-D input supporting 3D Frame Sequential up to 30Hz per eye. Also supports the domestic Blu-Ray formats. See supported signal input modes on page 86.

4. HDMI 1 / HDMI 2

HDMI 2.0 inputs supporting **Frame Sequential**, **Top and Bottom**, **Side By Side** and **Frame packing** 3D formats. See supported signal input modes on page 86. Connect an **HDMI** cable to the connector.

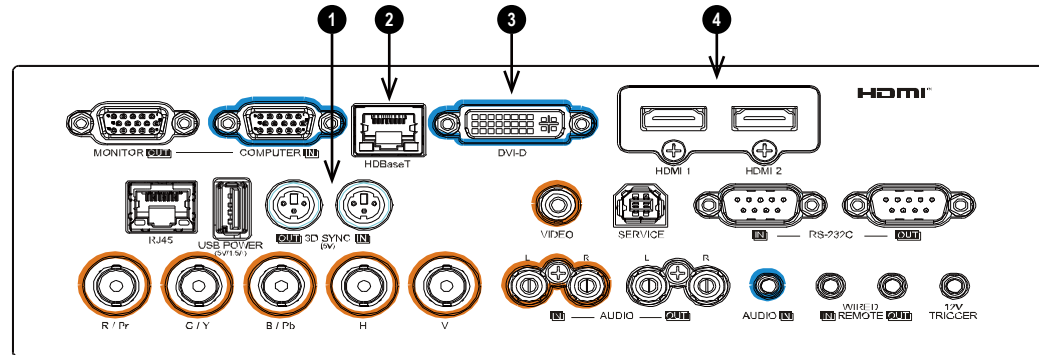

Notes



Set **3D Format** in the 3D menu to match the format of the incoming signal.

3D Sync

1. 3D Sync In
2. IR emitter or Zscreen

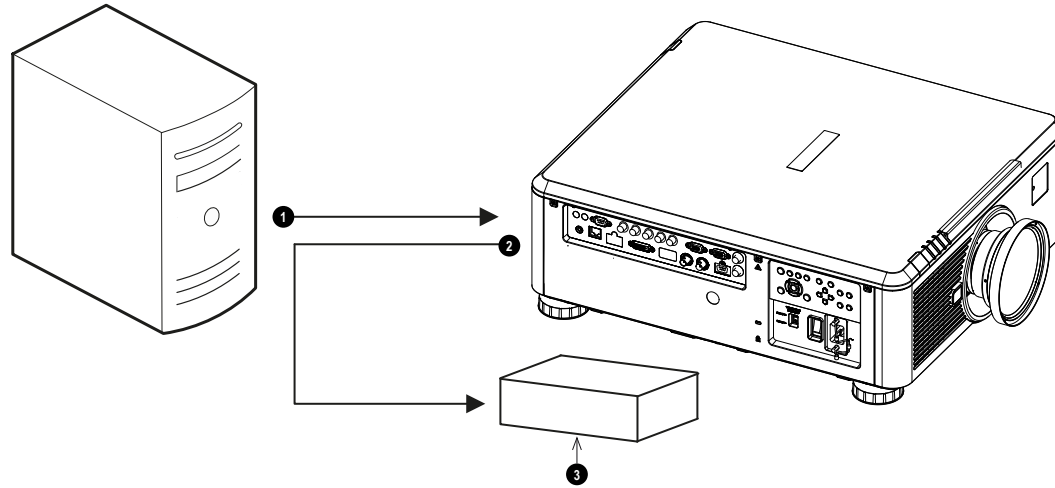

Notes

Control connections

1. RJ45

This dedicated LAN connection can be used if **HDBaseT/LAN** is already being used for HDBaseT signal input.

2. HDBaseT

The projector's features can be controlled via a HDBase-T or LAN connection, using a terminal-emulation program.

3. RS232

All of the projector's features can be controlled via a serial connection, using commands described in the **Protocol Guide**. Use a straight-through cable to connect directly to a computer.

4. Wired Remote

The remote control can be connected using a standard 3.5 mm mini jack cable (tip-ring-sleeve, or TRS).

5. 12V Trigger

A trigger output can be used to control an electrically operated screen. The screen will be automatically deployed when the projector starts up and retracted when the projector shuts down.

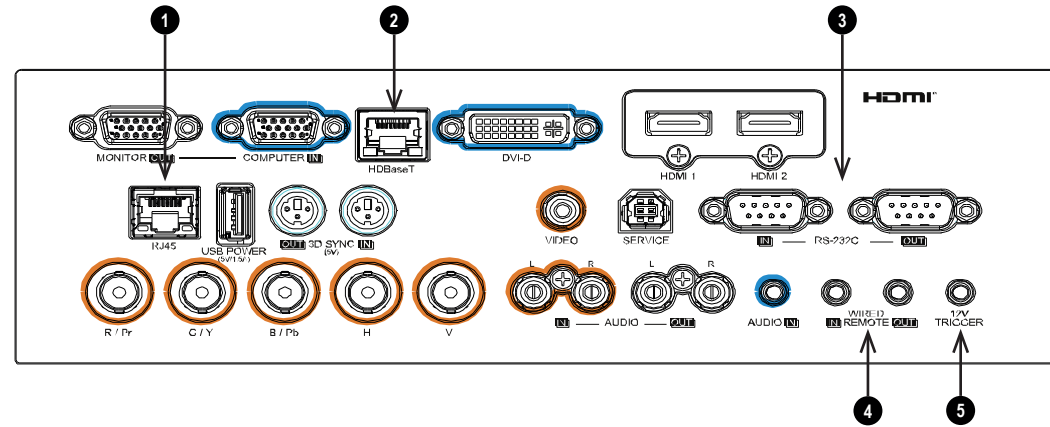

Notes

For a list of all commands used to control the projector via LAN, See communication parameter setup and Control Protocol on page 95.

Only one remote connection (RS232 or LAN) should be used at any one time.

With a LAN connection the projector can serve a web page offering status and projector controls.

LAN connection examples

The projector's features can be controlled via a LAN connection, using Digital Projection's **Projector Controller** application or a terminal emulation program.

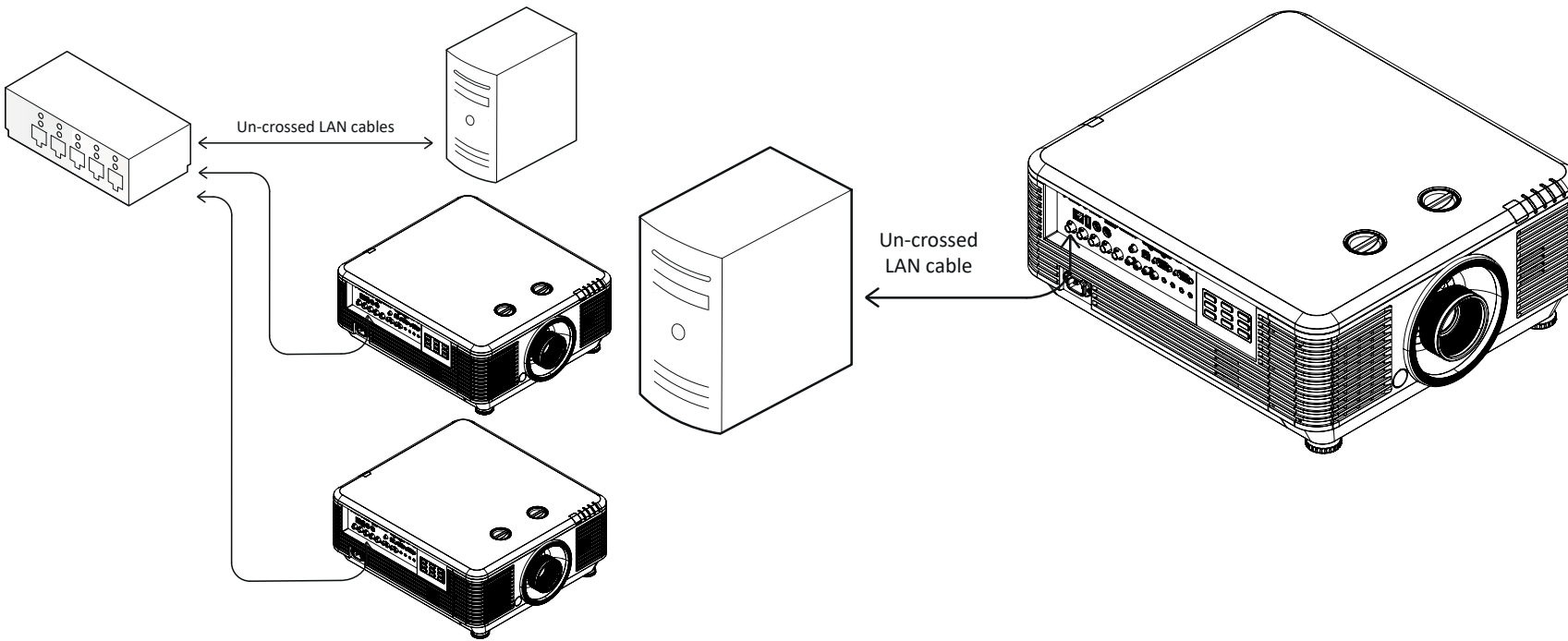

Notes

- ☞ *With a LAN connection the projector can serve a web page offering basic projector controls.*
- ☞ *For simultaneous HDBaseT and LAN connectivity, a third-party distribution product can be utilised to combine HDBaseT video stream with LAN connection for delivery to the projector.*

RS232 connection example

All of the projector's features can be controlled via a serial connection, using commands described in the **Protocol Guide**.

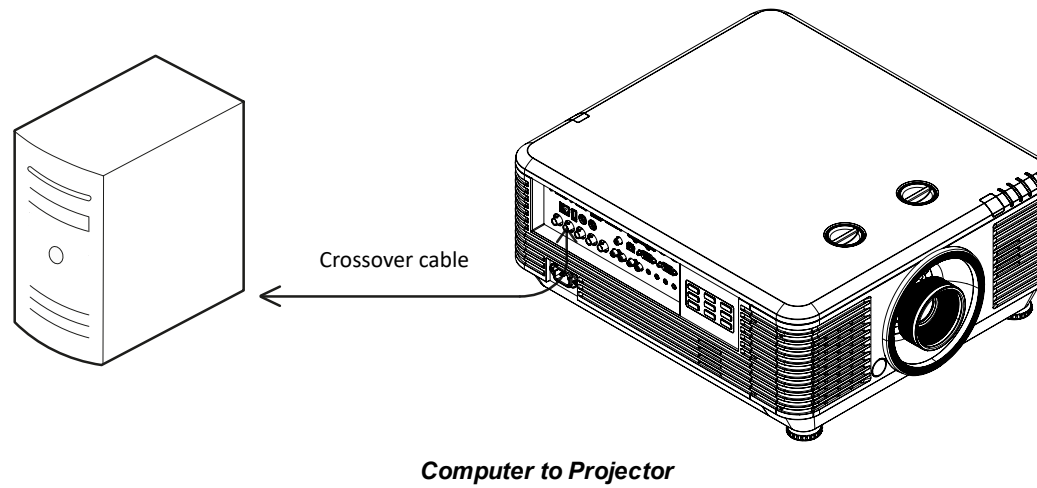

Notes

 See communication parameter setup and Control Protocol on page 95

This page is intentionally left blank

DIGITAL 
PROJECTION

A Delta Associate Company

E-Vision Laser 9000 Series

High Brightness Digital Video Projector

OPERATING GUIDE



Using the menus

Opening the Menu

Access the various menus using either the projector control panel or the remote control. On either device:

1. Press the **MENU** button. The on-screen display (OSD) opens showing the list of available menus

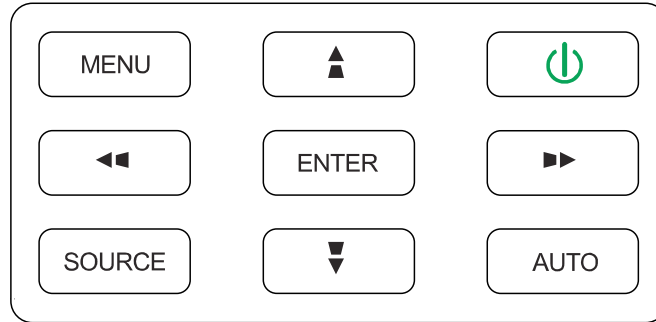

Projector control panel



Remote control

Opening a submenu

Move up and down the list using the **UP** and **DOWN** arrow buttons.

To open a submenu:

1. Press **ENTER** on the control panel or remote control.

Notes

Exiting menus and closing the OSD

To go back to the previous page:

1. Press **EXIT**.

To close the OSD:

1. Press **MENU**.

Or:

1. Go back to the top level menu
2. Press **EXIT**.

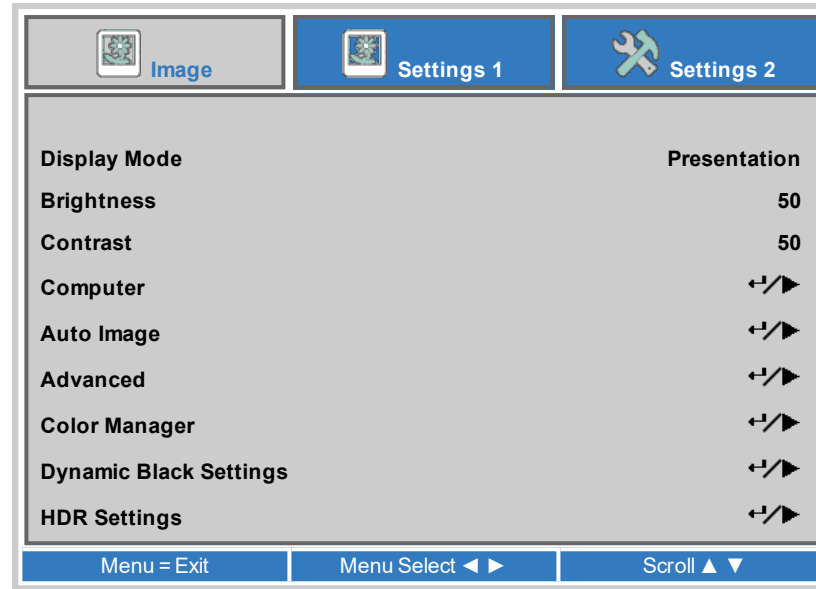

Notes

Inside the Menu

When you open the OSD, a menu is displayed. There are three main menus:

- Image
- Settings 1
- Settings 2

Each menu is displayed at the top of the OSD. Available menus are highlighted in blue. The menu you are currently viewing is highlighted in gray.

The contents of each menu consists of the following elements:

- The path to the current menu. This is displayed when you are accessing a submenu.
- Highlighted item
- Available and unavailable items. Unavailable items appear a pale gray color. Whether an item is available may depend on other settings.
- The text or symbol to the right of an item shows whether the item:
 - has a value that can be changed (the current value is shown)
 - opens a sub-menu (a return/right arrow button is displayed)

The bottom of the OSD shows instructions for navigating the OSD. The instructions are highlighted in blue and change for each menu and submenu.

Accessing sub menus

Use the **UP** and **DOWN** arrow buttons to highlight the sub-menu, then press **RETURN** or the **RIGHT ARROW** button.

Open Main Menu	Available Main Menu	Available Main Menu
Path (Main Menu ► Submenu)		
Item		Value
Highlighted Item		Value
Unavailable Item		
Item		Submenu ↵/▶
Item		Value Presentation
Item		Value 50
Instruction	Instruction	Instruction

Notes

Editing projector settings

If the highlighted menu item contains a list of values to choose from, you can change the value by doing the following:

1. Press the **UP** and **DOWN** arrow buttons to highlight the menu item.
2. Press the **LEFT** and **RIGHT** arrow buttons to change the value.

Menu	Menu	Menu
Item		Value
Highlighted Item		Value
Item		Value
Item		Value
Item		Value
Item		Value
Instruction	Instruction	Instruction

Notes



Some menu items may be unavailable due to settings in other menus. Unavailable menu items appear gray.

Executing commands

Some items are a command. Press **RETURN** or the **RIGHT ARROW** button.

You may be asked for confirmation. Use the **RETURN** or the **RIGHT ARROW** to confirm, or the **LEFT ARROW** to cancel.

Using a slider to set a value

Some parameters show a slider. To set such a parameter:

1. Press the **LEFT** or **RIGHT** arrow button, or **RETURN**. The arrow buttons will open the slider and adjust the value at the same time. **RETURN** will open the slider without altering the initial value.
2. Use the **LEFT** and **RIGHT** arrow buttons to move the slider.
3. When ready, press **RETURN** to exit the slider and return to the menu.

Menu	Menu	Menu
Item		Value
Highlighted Item		Value
Item		Value
Item		Value
Item		Value
Item		Value
Instruction	Instruction	Instruction

Editing numeric values

Some parameters take numeric values without using sliders - for example IP addresses.

1. Use the **UP** and **DOWN** arrow buttons to highlight the row containing the numeric field you wish to edit.
2. Press **RIGHT ARROW** button to enter edit mode. A numeric field in edit mode is white text on blue background
3. In edit mode:
 - Use the **UP** arrow button to increase the numeric value.
 - Use the **DOWN** arrow button to decrease the numeric value.
4. Use the **LEFT** and **RIGHT** arrow buttons to edit the next or previous numeric fields within the same row.
5. Once ready, press **RETURN** or the **LEFT ARROW** button to exit edit mode.

Menu	Menu	Menu
Item		255.255.255.255
Highlighted Item		255.255.255.255
Item		255.255.255.255
Item		255.255.255.255

Instruction Instruction Instruction

Notes

Using the projector

Image Menu

- Display Mode
Choose from **Presentation, Bright, Game, Movie, Vivid, TV, sRGB, DICOM SIM, User, and User 2.**
Use a different setting depending the type of input source.
- Brightness, Contrast
Use the slider to set the level as required.
- Computer
Access the submenu to edit the settings.
- Auto Image
Activate this option to automatically adjust the phase, tracking, size and position of the display.
- Advanced, Color Manager, Dynamic Black Settings, HDR Settings
Access the submenu to edit the settings.

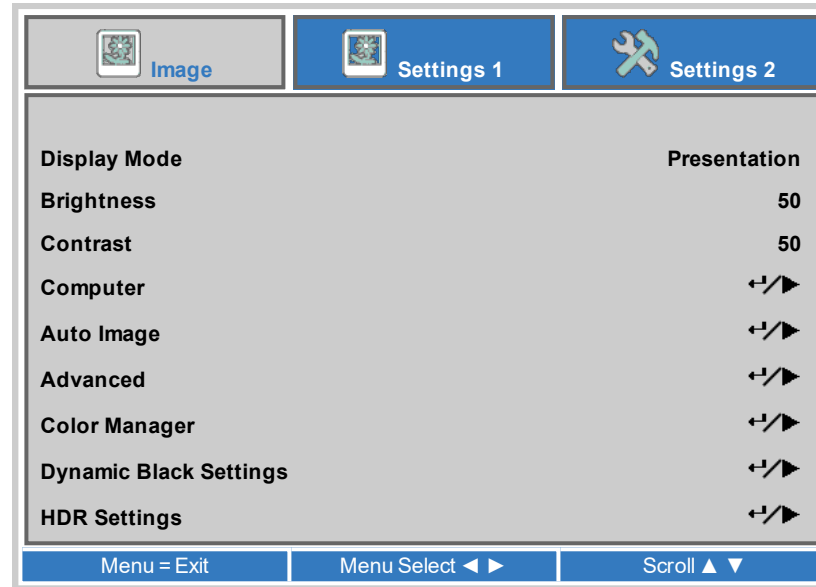

Notes





DICOM is a simulation mode and should only be used for training and other non-medical diagnosis purposes.

Computer

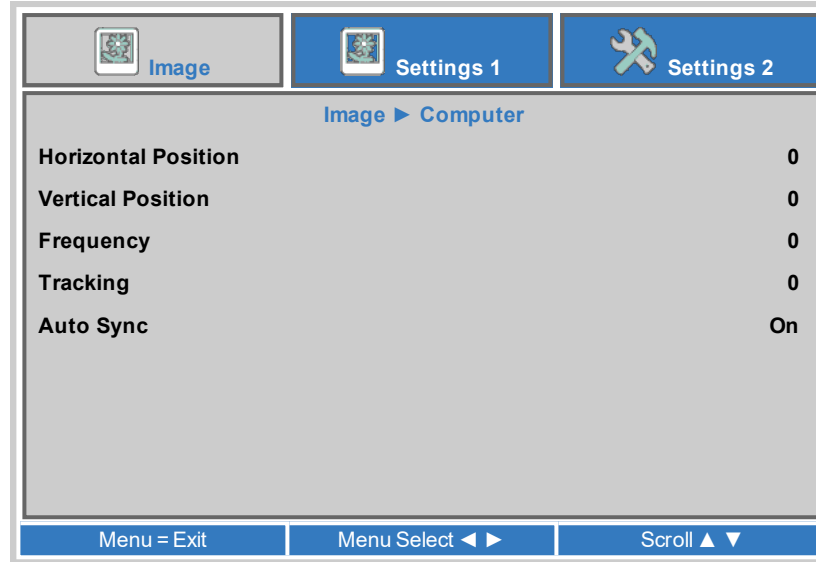
- Horizontal Position, Vertical Position
Adjusts the horizontal and vertical display position. Use the slider to set the level as required.
- Frequency
Adjusts the phase of the pixel sampling clock relative to the incoming signal. Adjust the phase if noise is visible. Use the slider to set the level as required.
- Tracking
Adjusts the frequency of the pixel sampling clock. Flicker or vertical banding indicate poor tracking. Use the slider to set the level as required.
- Auto Sync
Adjusts the horizontal and vertical position of the display based on the input source. Select from **On** or **Off**.



Notes

-  Some of the settings within the Position and Phase sub-menu, Frequency, Tracking and Auto Sync, affect only VGA input source. These settings are not available if the projector is using a different source.
-  Adjust the Frequency after adjusting Tracking.

Advanced

- Brilliant Color, Sharpness
Use the slider to set the level as required.
- Gamma
Choose a de-gamma curve from **1.8, 2.0, 2.2, 2.4, B&W, Linear**
Used correctly, the **Gamma** setting can improve contrast while maintaining good details for blacks and whites. If excess ambient light washes out the image and it is difficult to see details in dark areas, lower the **Gamma** setting to compensate. This improves contrast while maintaining good details for blacks. Conversely, if the image is washed out and unnatural, with excessive detail in black areas, increase the setting.
- Color Temperature
Choose from **Warm, Normal, Cold**
- Video AGC
Select **ON** to activate the automatic gain control for the video source.
- Video Saturation, Video Tint
Adjust the saturation and hue for the video source.
- White Balance
Access the submenu to edit the settings.

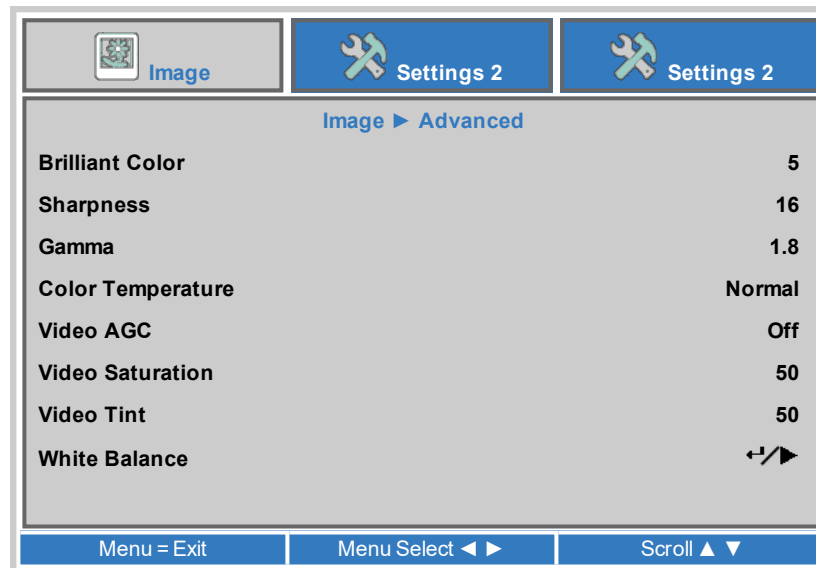

White Balance

- R Gain, G Gain, B Gain
Adjust the bright part of the scale for red, green and blue colors.
- R Offset, G Offset, B Offset
Adjust the black levels for red, green and blue colors.

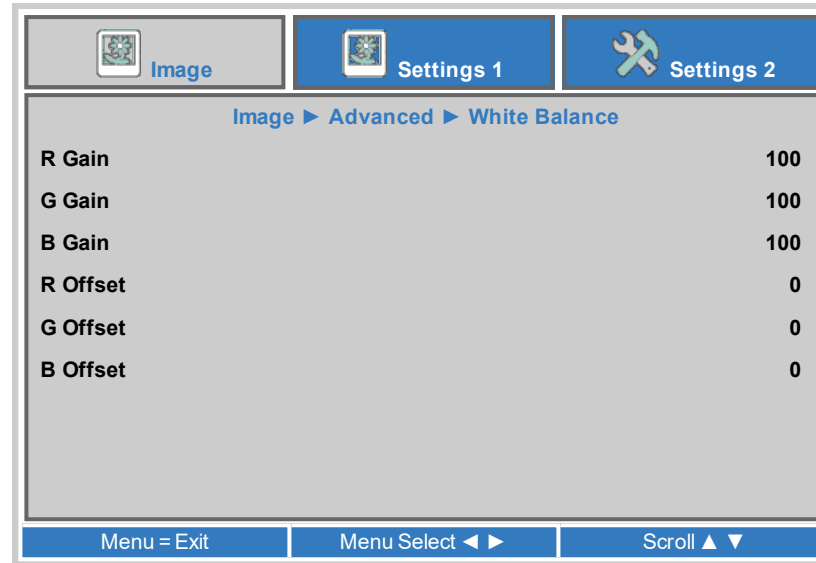

Notes

Color Manager

Access the submenu to edit the settings.

Adjust **Hue**, **Saturation** and **Gain** settings for each individual color to improve the color balance of the projected image.

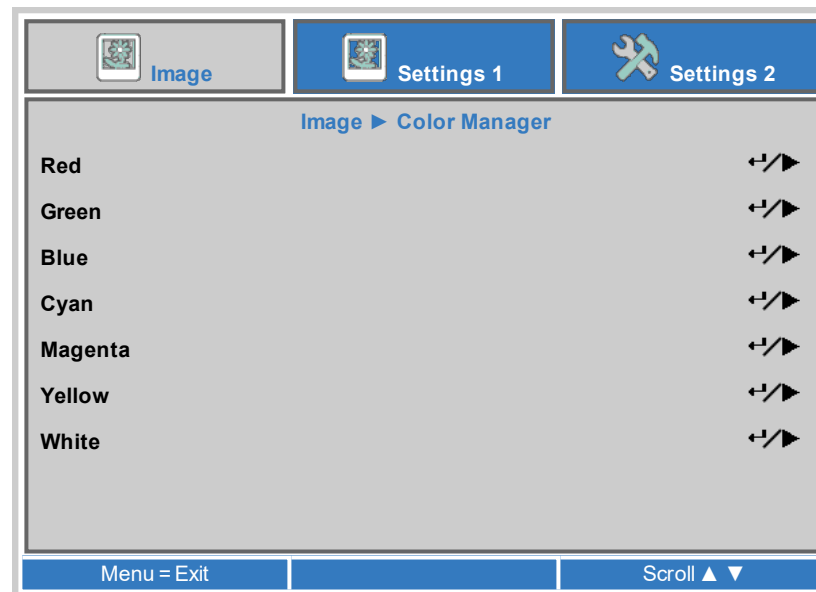

Color manager parameters explained

The levels of hue, saturation and gain in the Color Manager menu change the color values in the following ways:

1. **Hue** Specifies the position of each color (red, yellow, green, cyan, blue and magenta) relative to its neighboring colors.
2. **Saturation** Specifies the level of white in each color (i.e. how “pale” each color is).
3. **Gain** Controls the amount of light that goes into each color, i.e. the lowest gain would produce black.

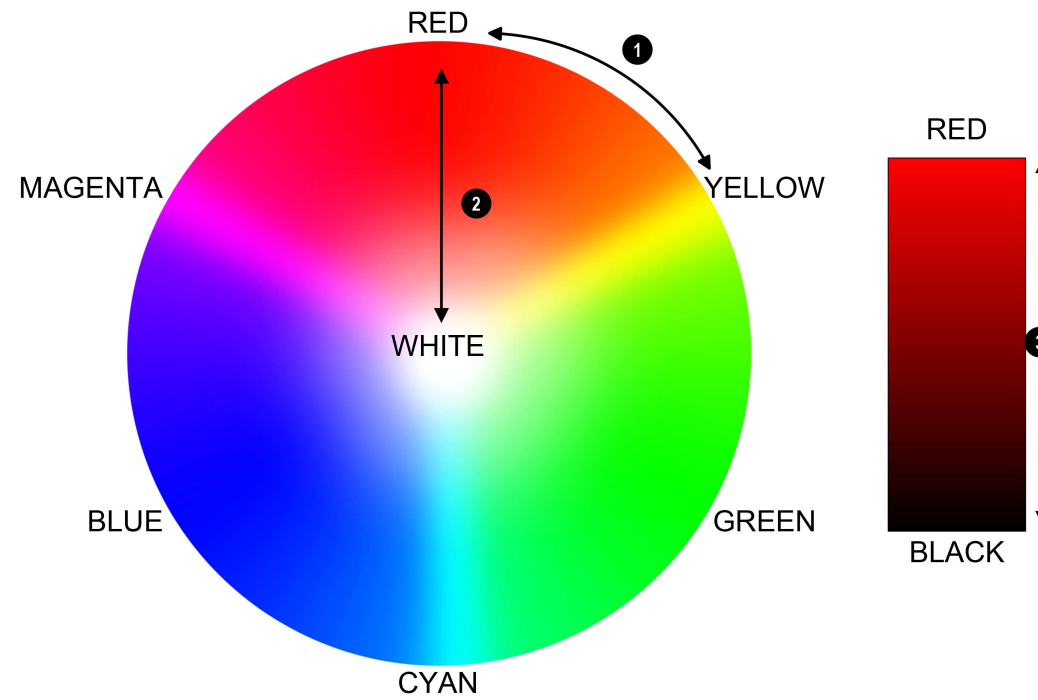

Notes

Dynamic Black Setting

- **Dynamic Black**
Set to On to allow for increased contrast in darker scenes by modulating the light source.
- **Light Off Timer**
When **Dynamic Black** is **On**, the **Light Off Timer** will define if laser light source will turn off after a period of time has passed. The options are: **Disable, 0.5 sec, 1 sec, 2 sec, 3 sec, 4 sec** (seconds).

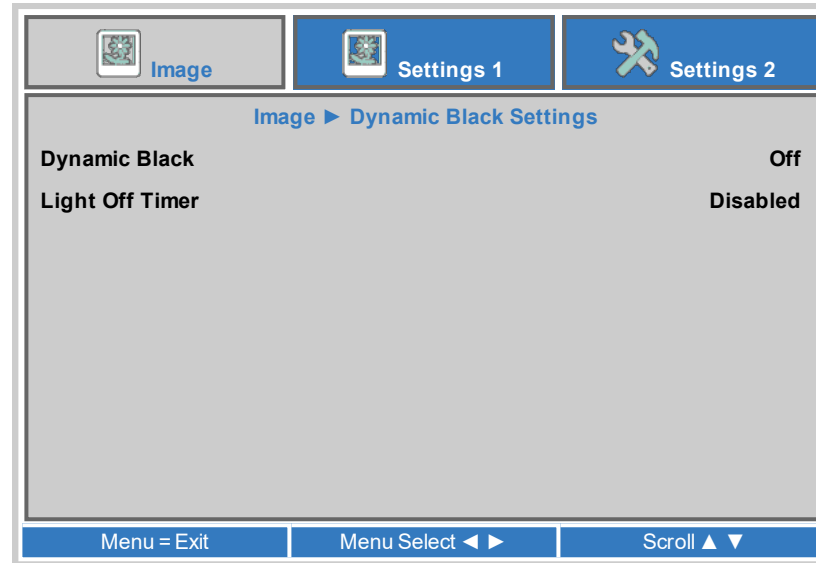

Notes

HDR Settings

- HDR Control
Choose from **Off**, **Auto** and **On**.
- HDR Mode
Choose from **PQ-L300**, **PQ-L400**, **PQ-L500** and **PQ-L600** modes when **HDR Control** is set to On.
HDR (High Dynamic Range) is a form of gamma developed to create more realistic experience when viewing images delivered using this format, such as scenes with bright sunlight. Unlike traditional gamma, HDR is not device or installation independent. HDR content will come with a recommended brightness regardless of screen size.
For best results, as a guideline, the following screens sizes are suggested.

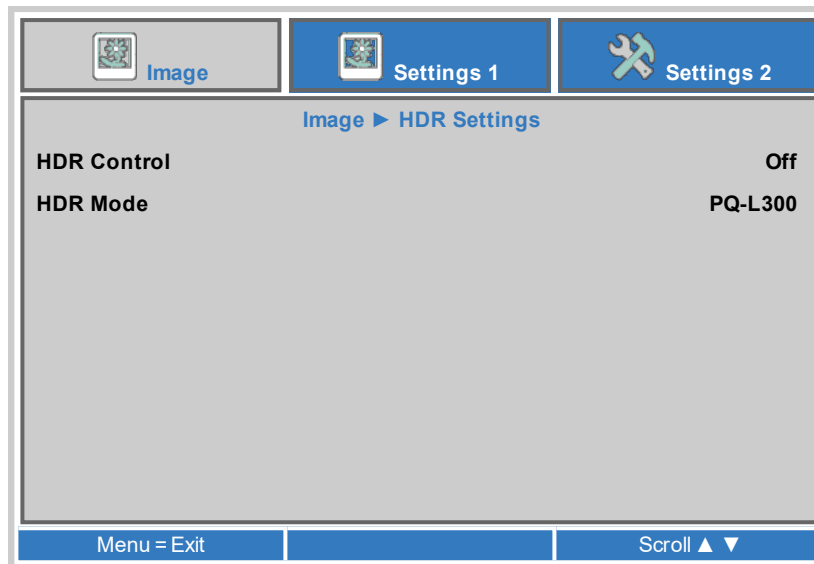

HDR Screen sizes		Screen width (cm)				
Model	Lumens	300 NIT	400 NIT	500 NIT	600 NIT	1000 NIT
EVL 9000	9,000	390.6cm	338.5cm	302.8cm	276.2cm	214.1cm

HDR options should only be used with media players and sources equipped with HDR capability and outputting HDR content. Perceptual Quantizer (PQ) is the digitizing concept for capture and display and provides metadata to enable the display to understand the coding of the content. The NIT numbers relate to the brightness of the viewing conditions in NIT. NIT is the unit of brightness measurement for monitors and LED walls that emit light rather than reflect it such as a projection screen. However it is a reference to the brightness you would choose for a given environment.

Notes

Settings 1 Menu

- **Source**
Access the submenu to edit the settings. Choose from **HDMI 1**, **HDMI 2**, **DVI**, **VGA** (Computer In), **BNC**, **Composite Video** and **HDBaseT**.
- **Projection**
Choose from **Desktop Front**, **Desktop Rear**, **Ceiling Front** and **Ceiling Rear**.
- **Aspect Ratio**
Set the aspect ratio for the projected image. Choose from **Fill**, **4:3**, **16:9**, **Letter Box**, **Native**, **2.35:1**.
- **Keystone**
Access the submenu to edit the settings.
- **Digital Zoom**
Adjust to zoom into the center of the image. Use the slider to set the level as required.
- **Audio, Advanced 1, Advanced 2, 4 Corner**
Access the submenu to edit the settings.

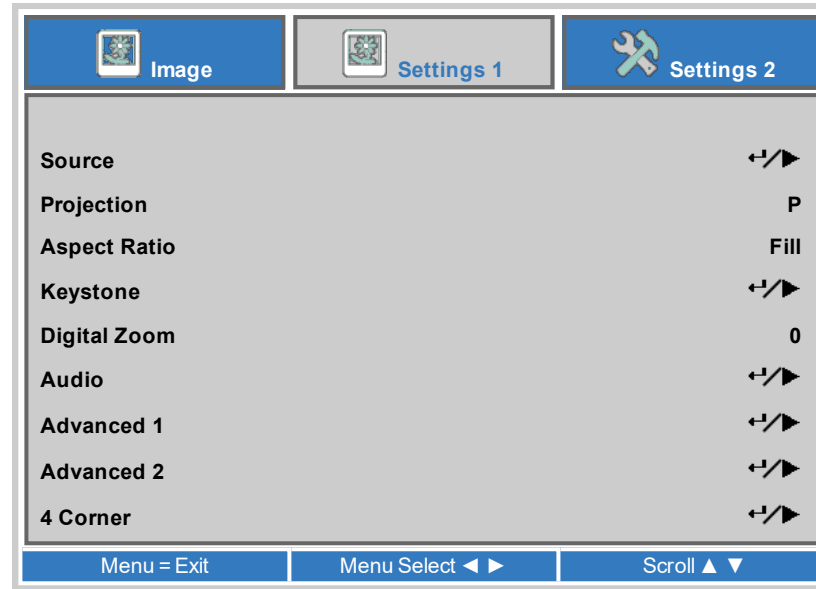

Notes

Keystone

Use this setting to compensate for any distortion caused by the projector being in a different horizontal or vertical plane to the screen.

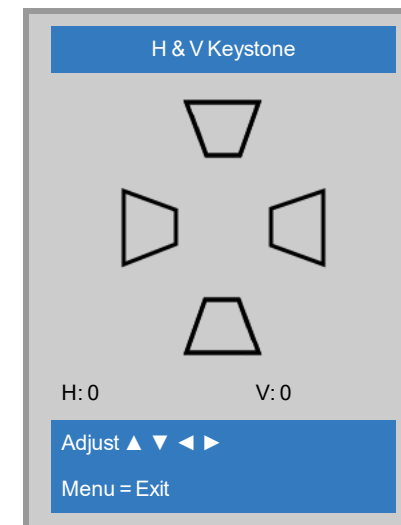

 *Keystone correction will reduce the resolution of the original image.*

Keystone settings

1. **Projector to the left** The projector is positioned to the left of the screen. To correct, apply a positive **Horizontal Keystone** value using the **RIGHT** arrow button.
2. **Projector to the right** The projector is positioned to the right of the screen. To correct, apply a negative **Horizontal Keystone** value using the **LEFT** arrow button.
3. **Projector high** The projector is positioned above the screen at a downward angle. To correct, apply a negative **Vertical Keystone** value using the **DOWN** arrow button.
4. **Projector low** The projector is positioned below the screen at an upward angle. To correct, apply a positive **Vertical Keystone** value using the **UP** arrow button.
5. **Projector straight** The projector is directly opposite the screen at a right angle both horizontally and vertically. No correction is needed.

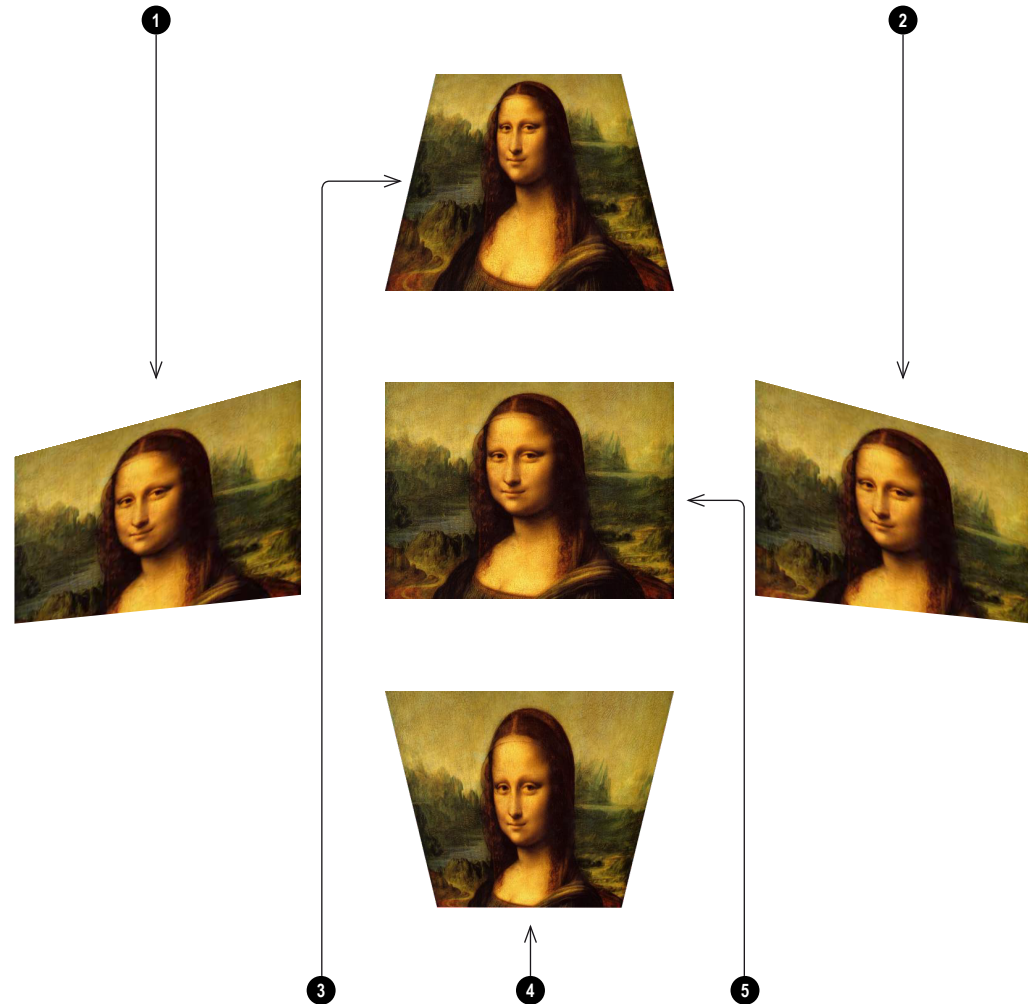

Horizontal and vertical keystone corrections

Notes

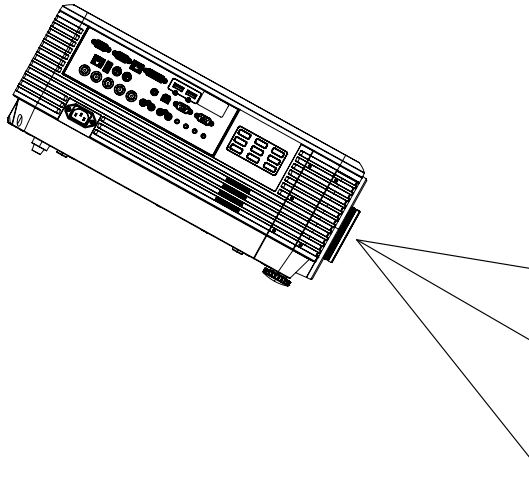
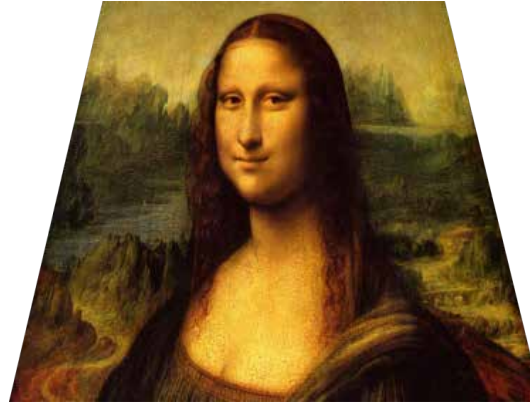
Keystone example*The projector is positioned at an angle**The resulting image is distorted**The image is corrected when Keystone is applied***Notes****Audio**

- **Volume**
Adjusts the volume output from the L&R audio outputs (L+R RCA). Use the slider to set the level as required.
- **Mute**
Mutes the audio output from the L&R audio outputs (L+R RCA). Set to **On** or **Off**.

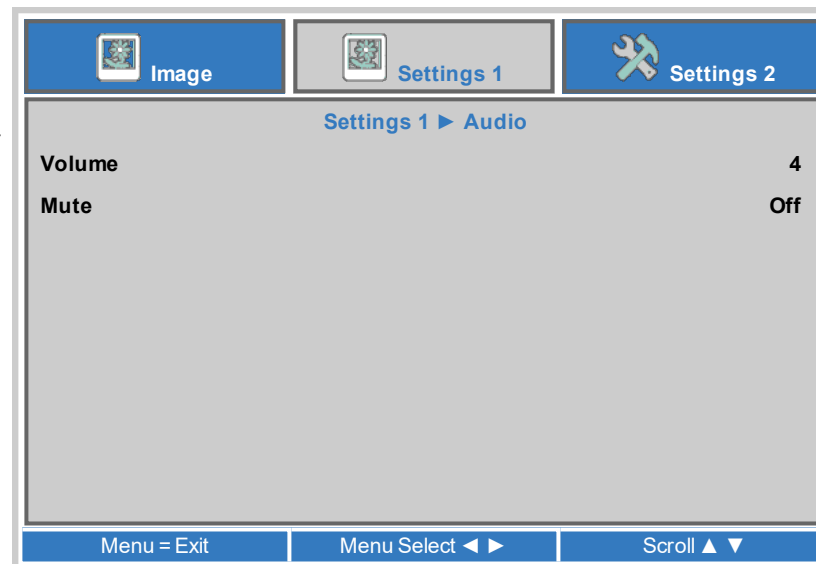

Advanced 1

- **Language**
Choose a language for the OSD from a choice of 27 available OSD languages.
- **Security Lock**
Switches the security lock **On** or **Off**
- **Blank Screen**
Select a color for the blank screen function operated by the remote. Choose from **Blank, Red, Green, Blue** or **White**.
- **Splash Logo**
Select the splash logo to be displayed on startup. Choose from **Std, Black** or **Blue**.
- **Closed Captioning**
Switches closed captioning **On** or **Off**.
- **Keypad Lock**
Locks the keypad buttons on the remote. Press the ▼ key on the remote for 5 seconds to re-enable the keypad buttons.
- **3D Setting**
Access the submenu to edit the settings.

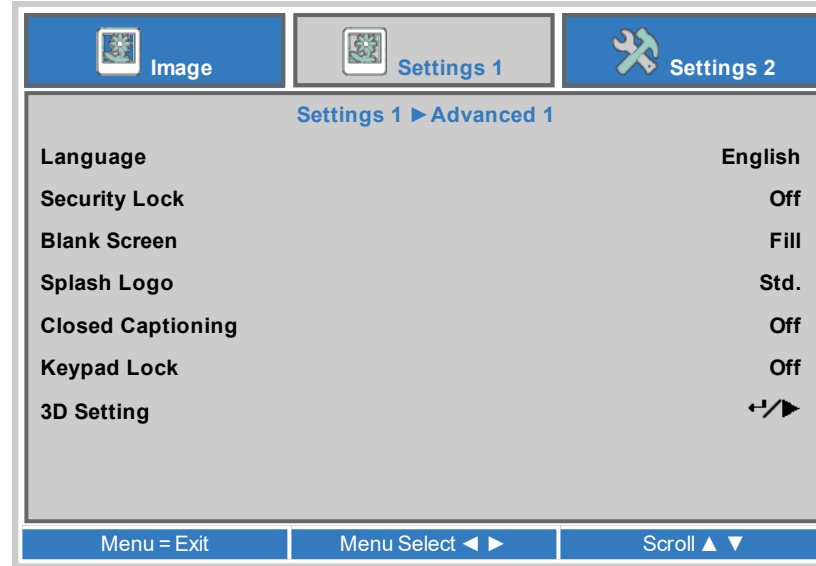

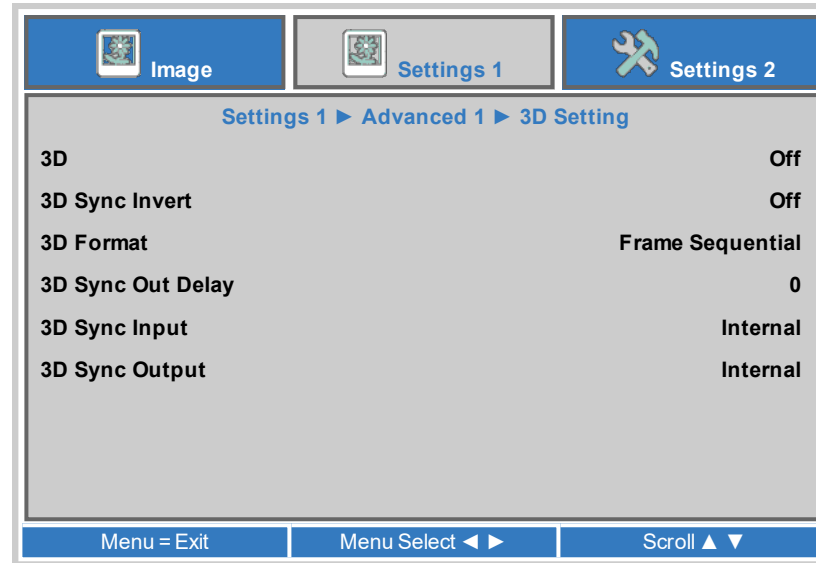

**Notes**

3D Setting

- 3D
Choose **DLP-Link** when using 3D shutter glasses. Choose **IR** when using infrared 3D glasses.
- 3D Sync Invert
Choose **On** to swap the left- and right-eye images, if they are displayed in the wrong order.
- 3D Format
Choose the appropriate 3D format. Choose from **Frame Packing, Top and Bottom, Side-by-Side, Frame Sequential** and **Auto**.
- 3D Sync Out Delay
Increase or decrease the 3D Sync Out Delay as required.
- 3D Sync Input
Choose from **Internal** or **External**.
- 3D Sync Output
Choose from **Internal** or **Bypass**



Notes

-  You must connect an Infrared emitter when using 3D IR (utilising Active 3D Glasses), alternatively a ZScreen system (utilising Passive Polarised 3D glasses) can be used.
-  If 3D is set to **Off**, all other 3D settings will be unavailable.
-  See 3D connections on page 37 for more information about supported 3D formats.
-  Also: See 3D types on the next page
-  See 3D formats on page 89 for 3D resolutions and frame rates.

3D types

To display a 3D image it is first necessary to select the 3D format of the source. These formats are described below:

- **Frame Sequential** For sequential 3D, an external sync is required to identify left and right frames. If no sync is available from the sequential source, the projector will generate an output sync, but it may then be necessary to manually set the Eye Swap each time the player is started.
- **Frame Packing**
- **Side-By-Side**
- **Top/Bottom**

3D Sync Out Delay needs to be set only once, to optimize the image for the glasses in use.

3D Sync Invert

The outgoing 3D frames are in pairs - the dominant frame being presented first. You can determine which frame should be the dominant one.

By convention the default setting is **Left**.

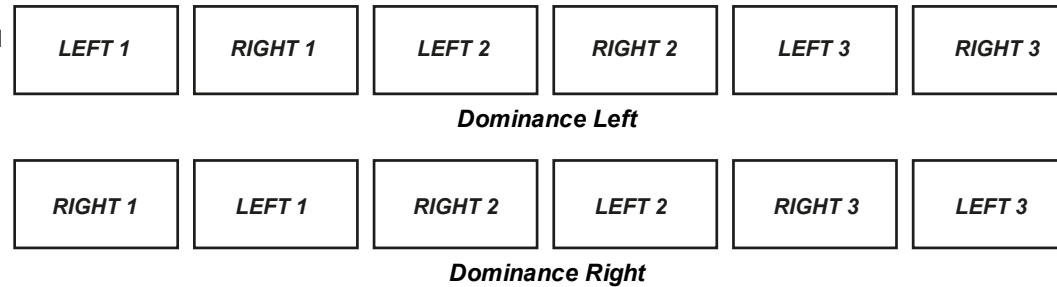

3D Sync Out Delay

The sync signal from the 3D server will be in phase with the frames generated by its graphics card. However, to compensate for switching delays in the glasses or ZScreen, **3D Sync Out Delay** is used to adjust the sync output signal sent to the ZScreen or 3D glasses to minimise overlapping (ghosting in the image when viewed through the 3D glasses).

Notes

Advanced 2

- **Test Pattern**
Select a test pattern to display. Choose from: None, RGB Ramps, Color Bars, Step Ramps, Check Board, Grid, Horizontal Lines, Vertical Lines, Diagonal Lines, Horizontal Ramp, Vertical Ramp, White, Red, Green, Blue, Black.
- **H Image Shift**
Use the slider to set the level as required.
- **V Image Shift**
Use the slider to set the level as required.

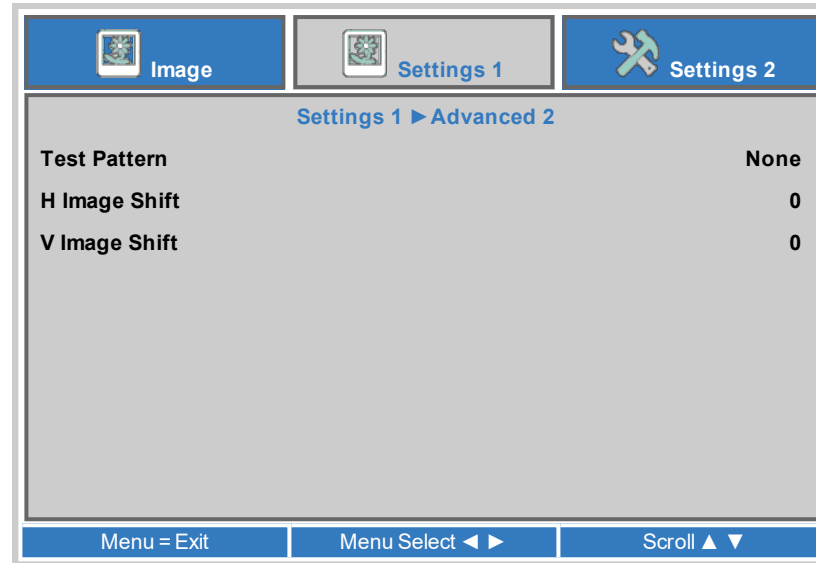

4 Corner

For each corner, apply horizontal and / or vertical correction as necessary to restore the rectangular shape of the image.

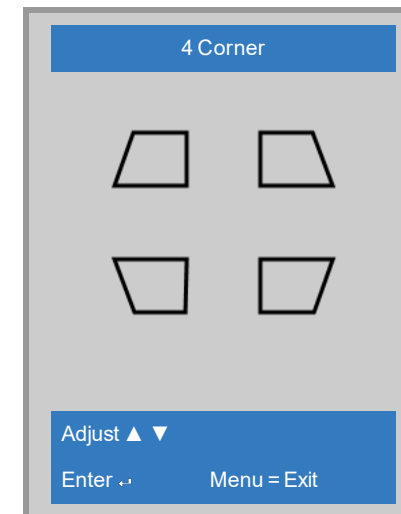

Notes

*Corner corrections provide a simple setup for awkward installations and irregular shaped screens that may distort the image. To apply a similar (but less flexible) correction, while preserving the original aspect ratio of the image, use the **Keystone** menu.*

Settings 2 Menu

- Auto Source
If this setting is **On**, the projector will automatically search for an active input source.
- No Signal Power Off (min)
Set a duration to wait (0 to 180 mins) before switching the light source off when there is no input signal.
- Auto Power On
Set to **On** to automatically power the projector on when the power cable is inserted. When set to **Off**, use the power button on the control panel or the on and off buttons on the remote to switch the projector on or off.
- Light Setting
Access the submenu to edit the settings.
- Reset All
Press **↔/▶** to reset all settings to the factory defaults.
- Status. Advanced 1, Advanced 2
Access the submenu to edit the settings.

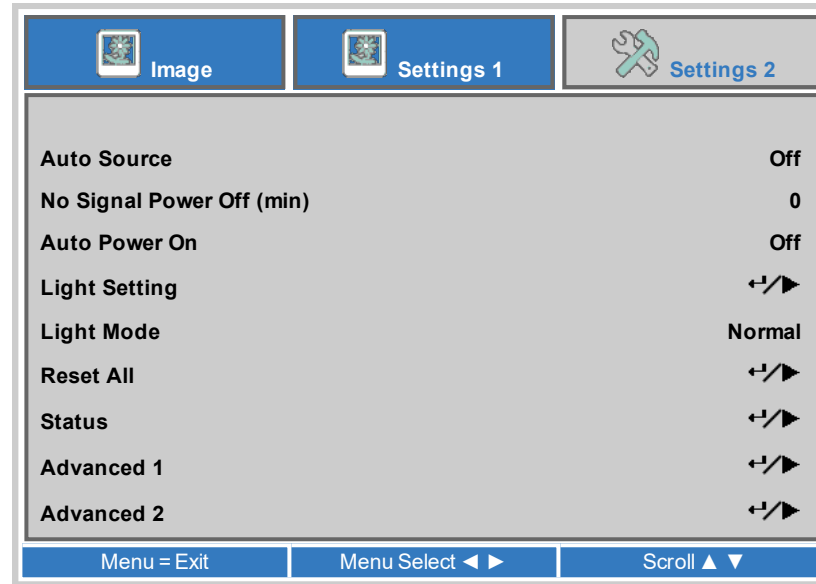

Notes

Light Setting

- Light Mode
 - **Normal** will set the power to 100%.
 - **Eco** will automatically set the laser power to 80%.
 - **ECO Plus**
 - **Dimming**
 - **Extreme Dimming** will reduce the laser power to 50% when blank screen is active.
 - **Custom Light** will activate the custom light and constant brightness settings.
- Custom Light
This setting is only available if **Light Mode** is set to **Custom Light**.
Choose a value between 50 and 200, ranging from 25% to 100% laser power.
- Constant Brightness
Once the **Light Mode** has been set to **Custom Light**, then Constant Brightness can be turned **ON**.
The Constant Brightness setting will maintain the projectors set brightness until the maximum laser power has been reached (this maximum laser power will decrease overtime). Hence, the lower the set Constant Brightness power level the longer the set brightness output will be maintained.

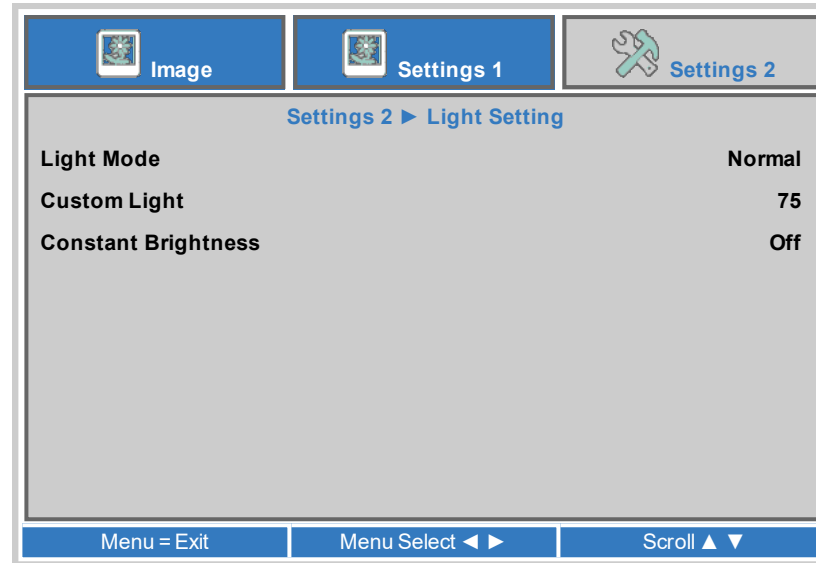

Notes

Status

This menu gives information about software and hardware configuration, input source and laser operating times.

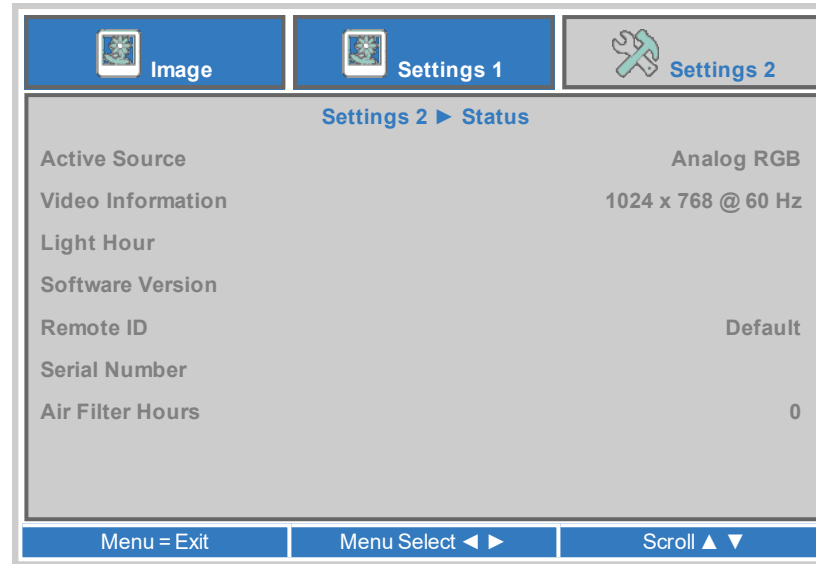



Notes

Advanced 1

- **Menu Position**
Choose a position for the menu on the display.
- **Translucent Menu**
Choose the level of translucency for the menu. Choose from **0%**, **25%**, **50%**, **75%**, **100%**.
- **Low Power Mode**
 - Choose **On** to disable power on by LAN when the projector is in low power mode.
 - Choose **On By LAN** to allow power on by LAN when the projector is in low power mode.
- **Fan Speed**
Choose from **Normal** or **High**.
- **Light Info**
Access the submenu to view the number of light hours used by each light mode.
- **Projector ID**
Edit to set a projector ID number.
- **Remote ID**
Choose from **Default** or a value from **1** to **7**.
- **Network, HDBaseT-IR/RS232**
Access the submenu to edit the settings.

**Notes**

-  *High fan speed is recommended when the projector is located in high temperature, high humidity, or high altitude areas*
-  *Low Power Mode is set to on by HDBase-T when HDBase-T Setting is set to on.*
-  *RS232 and LAN control is disabled when HDBase-T Setting is set to on.*

HDBaseT

- HDBaseT-IR/RS232
Set to **On** to enable HDBaseT controls
- Front IR, Rear IR
Set to **On** to enable, or to Off to disable the infrared remote control sensors, located at the front or the rear of the projector.

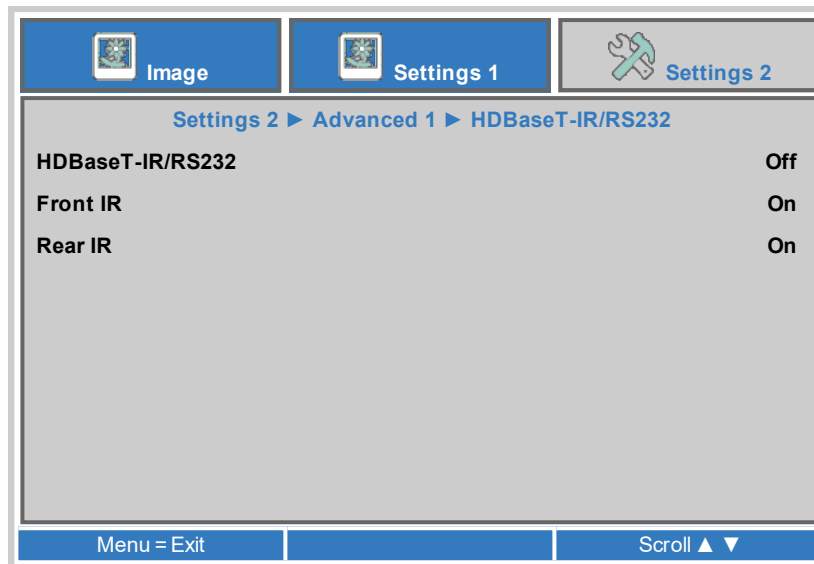

Notes

 See Control connections on page 39 for more information about HDBaseT controls.

Network

- Network State
Displays the current network status.
- DHCP, IP Address, Subnet Mask, Gateway, DNS
Set **DHCP** to **On** if the IP address is to be assigned by a DHCP server, or Off if it is to be set here.
If **DHCP** is On, it will not be possible to edit **IP Address, Subnet Mask, Gateway** or **DNS**.
If **DHCP** is set to **Off**, edit **IP Address, Subnet Mask, Gateway** and **DNS** as required.
- Apply
Select to apply any changes to the network setup.

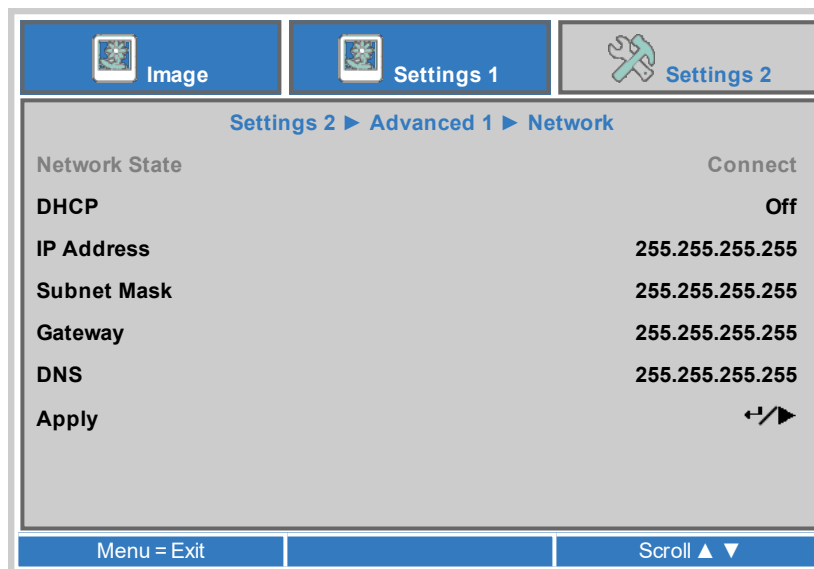

Advanced 2

- **Sleep Timer (min)**
Turns the projector off after a period of time. Set the number of minutes for the timer.
- **Source Filter**
Allows you to enable or disable individual input source connections. Access the submenu to edit the settings.
- **Air Filter Timer Reset**
Select enter to reset the air filter timer.
- **Color Space**
Choose from: **Auto, YUV, RGB.**
- **Quantization Range**
Choose from: **Auto, Full, Limited**
- **HDMI EDID**
Choose from **Enhanced** or **Standard.**

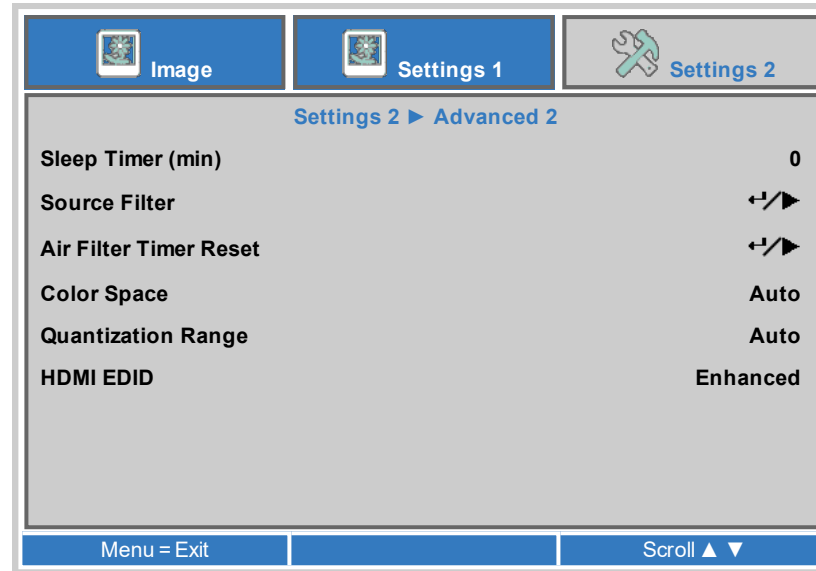
**Notes**

Served web pages

The served web pages allow you to control the projector remotely via LAN.

The default IP address is **192.168.0.100**.

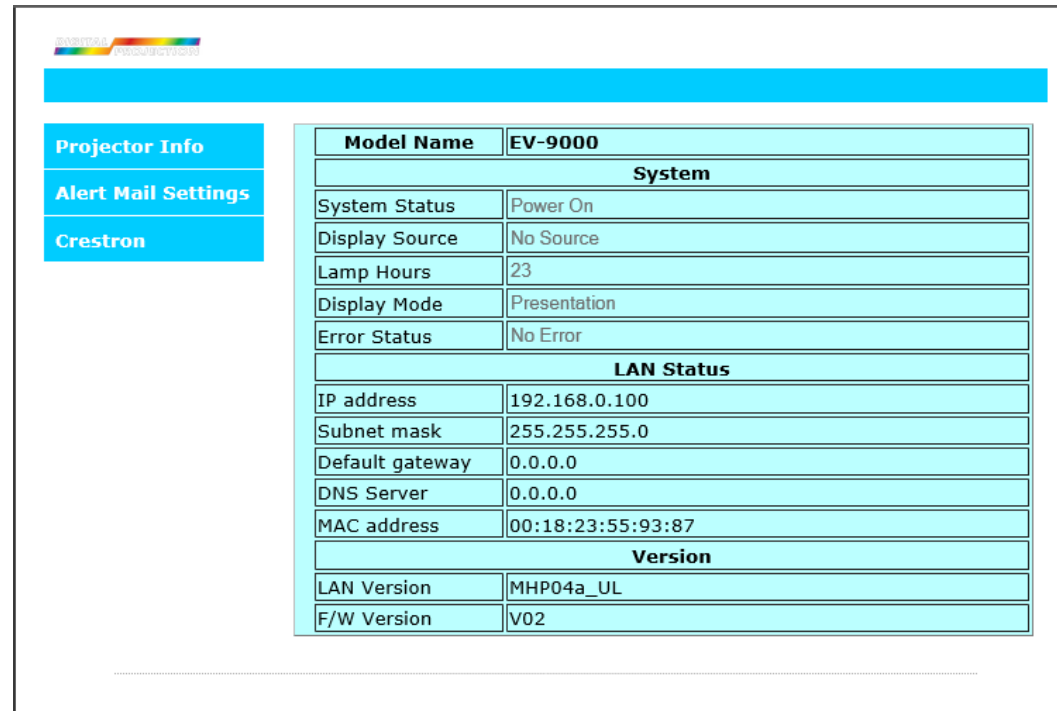

The screenshot shows the projector's web interface. On the left, there is a navigation menu with three items: "Projector Info", "Alert Mail Settings", and "Crestron". The "Projector Info" section is active, displaying a table of system and LAN status information.

Model Name	EV-9000
System	
System Status	Power On
Display Source	No Source
Lamp Hours	23
Display Mode	Presentation
Error Status	No Error
LAN Status	
IP address	192.168.0.100
Subnet mask	255.255.255.0
Default gateway	0.0.0.0
DNS Server	0.0.0.0
MAC address	00:18:23:55:93:87
Version	
LAN Version	MHP04a_UL
F/W Version	V02

Notes

The screenshot displays the Crestron web interface for the E-Vision Laser 9000 Series. At the top, there is a navigation bar with 'Tools', 'Info', and 'Contact IT Help' links. Below this is a 'DIGITAL PROJECTION' logo. The main control area features a 'Power' button (highlighted in green), 'Vol -', 'Mute', and 'Vol +' buttons. A 'Source List' menu is open, showing options: HDMI1, HDMI2, DVI, VGA, and BNC. To the right of the list are navigation buttons: 'Menu', 'Up', 'Auto', 'Left', 'Enter', 'Right', 'AV Mute', 'Down', and 'Source'. Below the source list is a 'Freeze', 'Contrast', 'Brightness', and 'Sharpness' control bar. The bottom of the interface shows the 'CRESTRON' logo and 'Expansion Options' text. The version 'Interface 2.7.2.6' is visible in the top right of the main content area.

Notes

Notes

Projector Info

Alert Mail Settings

Crestron

Send E-Mail

Enter the appropriate settings in the fields below:
(Your SMTP server may not require a user name or password.)

SMTP Server: **Port:**

User Name:

Password:

From:

To:

CC:

E-mail Alert Options:

Fan lock : **Over_Heat:**

Case Open: **Lamp Fail:**

Lamp Hours Over: **Filter Hours Over:**

Weekly Report:

DIGITAL 
PROJECTION

A Delta Associate Company

E-Vision Laser 9000 Series

High Brightness Digital Video Projector

REFERENCE GUIDE



Choosing a lens

A number of lenses are available. Which lens you choose depends on the screen size, image aspect ratio, throw distance and light output.

The following table shows all available lenses in order of their throw ratios:

Throw Ratio (.67" WUXGA)	Focus Range	Image size (Diagonal, AR 16:10)	Lens Shift (Full Height)	Part Number
0.77:1	0.4 m - 3.1 m	7.8" - 298.3"	V: -15% - 55% H: -5% - 5%	114-785
0.77 - 1.1:1	0.67 m - 12.1 m	60" - 300"	V: -15% - 55% H: -5% - 5%	119-001
1.10 - 1.30:1	1 m - 9 m	35.8" - 379.8"	V: -15% - 55% H: -5% - 5%	116-207
1.25 - 1.6:1	1.356 m - 8.078 m	50" - 300"	V: -15% - 55% H: -5% - 5%	119-430
1.54 - 1.93:1	0.95 m - 11.9 m	36.1" - 211"	V: -15% - 55% H: -5% - 5%	114-783
1.93 - 2.91:1	1.2 m - 29.8 m	32.1" - 481"	V: -15% - 55% H: -5% - 5%	114-784
3.00 - 5.00:1	3 m - 20 m	27.9" - 309.5"	V: -15% - 55% H: -5% - 5%	116-208

To choose a lens, calculate the **throw ratio** required. Allow a tolerance of +/- 3% in the throw ratio calculation.

Notes



Throw distance calculations are based on the distance from the outer end of the lens, which varies from lens to lens.

The lens extension is the distance between the front of the projector chassis and the outer end of the lens when it is fully extended.



Refer to the projector CAD drawings for individual lens extension figures.

Basic calculation

Identify the required lens by calculating the **throw ratio**.

A **throw ratio** is the ratio of the throw distance **2** to the screen width **1**:

$$\text{ThrowRatio} = \text{ThrowDistance} / \text{ScreenWidth}$$

1. Use the formula above to obtain the required throw ratio.
2. Allow a tolerance of +/- 3% in the throw ratio calculation and match the throw ratio with a lens from the table below:

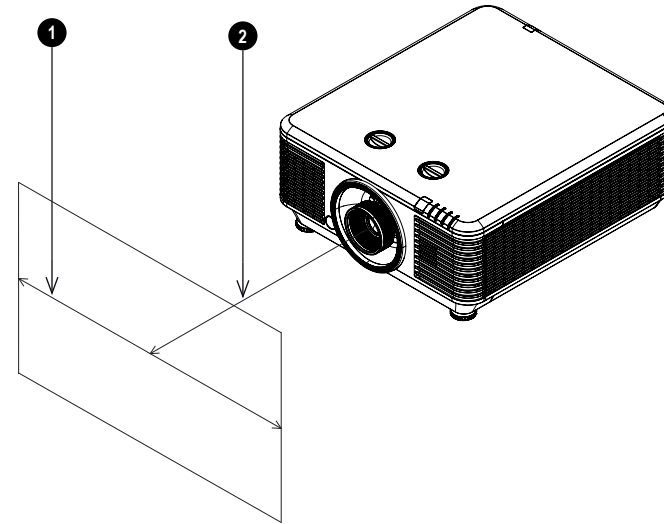

Throw Ratio Focus Range

0.77:1	0.4 m - 3.1 m
0.77 - 1.1:1	0.67 m - 12.1 m
1.10 - 1.30:1	1 m - 9 m
1.25 - 1.6:1	1.356 m - 8.078 m
1.54 - 1.93:1	0.95 m - 11.9 m
1.93 - 2.91:1	1.2 m - 2.98 m
3.00 - 5.00:1	3 m - 20 m

3. Ensure the required throw distance is within the range covered by the lens.

Notes

The basic calculation on this page does not take into consideration DMD™ and image size, which could affect the throw ratio. See Full lens calculation on page 75 for a more complex and realistic calculation.

When calculating the throw ratio, be sure to use identical measurement units for both the throw distance and the screen width.

See Choosing a lens on the previous page for information about individual lens part numbers

Basic calculation example

1. Calculate the throw ratio using the formula.
Your screen is **4.5m** wide and you wish to place the projector approximately **11m** from the screen. The throw ratio will then be
 $11 \div 4.5 = \mathbf{2.44}$
2. Match the result with the lens table.
The lens matching a throw ratio of 2.44 is the **1.93 - 2.91:1 lens**.
3. **Check whether the lens covers the required throw distance.**
The focus range quoted for the 1.93 - 2.91:1 lens is **1.2 - 2.98m**. The required distance of 11m is within the range.

INFORMATION YOU NEED FOR THIS CALCULATION

The throw ratio formula:

$$\mathbf{ThrowRatio = ThrowDistance / ScreenWidth}$$

Allow a tolerance of +/- 3% in the throw ratio calculation.

The lens table:

Throw Ratio Focus Range

0.77:1	0.4 m - 3.1 m
0.77 - 1.1:1	0.67 m - 12.1 m
1.10 - 1.30:1	1 m - 9 m
1.25 - 1.6:1	1.356 m - 8.078 m
1.54 - 1.93:1	0.95 m - 11.9 m
1.93 - 2.91:1	1.2 m - 29.8 m
3.00 - 5.00:1	3 m - 20 m

Notes

 The basic calculation on this page does not take into consideration DMD™ and image size, which could affect the throw ratio. See Full lens calculation on the facing page for a more complex and realistic calculation.

 See Choosing a lens on page 72 for information about individual lens part numbers.

Full lens calculation

Introducing TRC

The choice of lens will affect the image size and will address discrepancies between the DMD™ resolution and the source.

When an image fills the height of the DMD™ but not the width, it uses less than 100% of the DMD™ surface. A lens chosen using the basic formula may produce an image that is considerably smaller than the actual screen.

To compensate for loss of screen space in such situations, you need to increase the throw ratio using a **Throw Ratio Correction (TRC)**.

Example

Fig. 1 illustrates a 4:3 image within a 16:9 display

When a 16:9 projector is used for a 4:3 image, the image does not fill the width of the DMD™, creating a **pillarboxing** effect - blank spaces to the left and right.

Fig. 2 shows the same image projected on a 4:3 screen using a standard lens (chosen with the basic calculation).

The DMD™ accurately fills the width of the screen; however, the pillarboxing is now part of the projected image and is transferred to the screen.

The DMD™ does not fill the height of the screen, which has caused **letterboxing** - further blank spaces at the top and bottom of the screen.

The image is now surrounded by blank space, which can be removed if the throw ratio is increased.

Fig. 3 shows the image projected on the same screen with a lens chosen using TRC. The increased throw ratio has allowed the 4:3 image to fill the 4:3 screen seamlessly



Fig 1

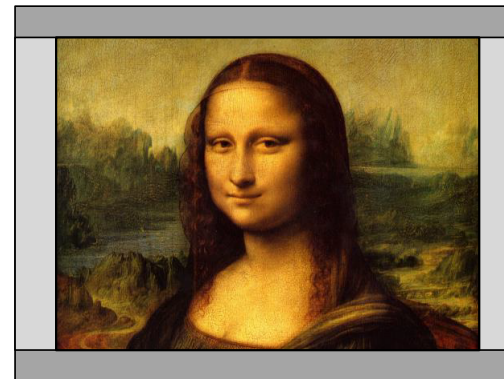



Fig 2



Fig 3

Notes

 TRC can only be applied if greater than 1. If TRC is 1 or less, disregard it and calculate the throw ratio using the basic formula.

Calculating TRC

To calculate TRC, use the following formula:

$$TRC = 1.6(DMD^{\text{TM}} \textit{ AspectRatio}) / \textit{ SourceAspectRatio}.$$

TRC table

Alternatively, you can save time by referencing the following table, which shows the TRC value for some popular image formats:

2.35:1 (Scope)	1920 x 817 pixels	TRC < 1, not used
1.85:1 (Flat)	1920 x 1037 pixels	TRC < 1, not used
1.78:1 (16:9)	1920 x 1080 pixels	TRC < 1, not used
1.6:1 (16:10)	1920 x 1200 pixels	TRC < 1, not used (native aspect ratio)
1.33:1 (4:3)	1596 x 1200 pixels	TRC = 1.2
1.25:1 (5:4)	1500 x 1200 pixels	TRC = 1.28

Calculating the throw ratio with TRC

- For TRC > 1, amend the basic throw ratio formula as follows:

$$\textit{ ThrowRatio} = \textit{ ThrowDistance} / \textit{ ScreenWidth} * TRC$$

Allow a tolerance of +/- 3% in the throw ratio calculation.

- Once a throw ratio is established, identify the matching lens from the table:

Throw Ratio Focus Range

0.77:1	0.4 m - 3.1 m
0.77 - 1.1:1	0.67 m - 12.1 m
1.10 - 1.30:1	1 m - 9 m
1.25 - 1.6:1	1.356 m - 8.078 m
1.54 - 1.93:1	0.95 m - 11.9 m
1.93 - 2.91:1	1.2 m - 29.8 m
3.00 - 5.00:1	3 m - 20 m

- Ensure the required throw distance is within the range of the matching lens.

Notes



TRC can only be applied if greater than 1. If TRC is 1 or less, disregard it and calculate the throw ratio using the basic formula.



TRC can only be applied if greater than 1. If TRC is 1 or less, disregard it and calculate the throw ratio using the basic formula.

Full lens calculation example

Your screen is **4.5m** wide; you wish to place the projector approximately **11m** from the screen. The source is **4:3**.

1. Calculate TRC as follows:
TRC = 1.6 / 1.33 = 1.2.
2. Calculate the throw ratio:
Throw ratio = 11 / 4.5 x 1.2 = **2.04**
3. Allow a tolerance of +/- 3% in the throw ratio calculation and find a match in the lens table.
The table shows that the matching lens is **the 1.93 - 2.91:1 lens**.
4. Check whether the lens covers the required throw distance.
The focus range quoted for the 1.93 - 2.91:1 lens is **1.2m - 29.8m**. The required distance of 11 m is within the range.

INFORMATION YOU NEED FOR THESE CALCULATIONS

The TRC formula

TRC = DMD™ AspectRatio/SourceAspectRatio

The TRC table (to use instead of the formula)

2.35:1 (Scope) TRC < 1, not used
1.85:1 (Flat) TRC < 1, not used
1.78:1 (16:9) TRC < 1, not used
1.6:1 (16:10) TRC < 1, not used (native aspect ratio)
1.33:1 (4:3) TRC = 1.2
1.25:1 (5:4) TRC = 1.28

The throw ratio formula

ThrowRatio = ThrowDistance/ScreenWidth * TRC

Allow a tolerance of +/- 3% in the throw ratio calculation.

The lens table:

Throw Ratio Focus Range

0.77:1	0.4 m - 3.1 m
0.77 - 1.1:1	0.67 m - 12.1 m
1.10 - 1.30:1	1 m - 9 m
1.25 - 1.6:1	1.356 m - 8.078 m
1.54 - 1.93:1	0.95 m - 11.9 m
1.93 - 2.91:1	1.2 m - 29.8 m
3.00 - 5.00:1	3 m - 20 m

Notes

Screen requirements

Notes

Fitting the image to the display

If the source image supplied to the projector is smaller than the WUXGA resolution, the image will not fill the display. The following examples show how a number of common formats may be displayed, depending on your DMD™ resolution.

WUXGA images displayed full width

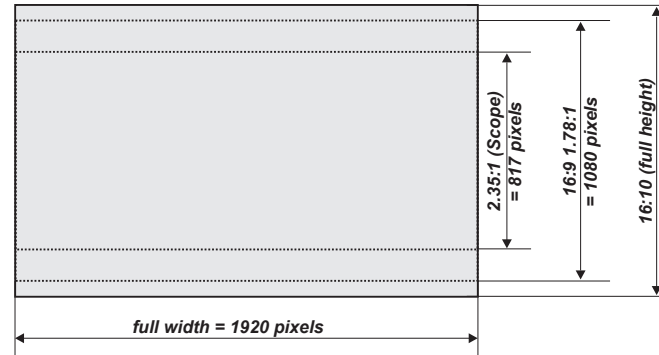

WUXGA images displayed with a height of 1200 pixels

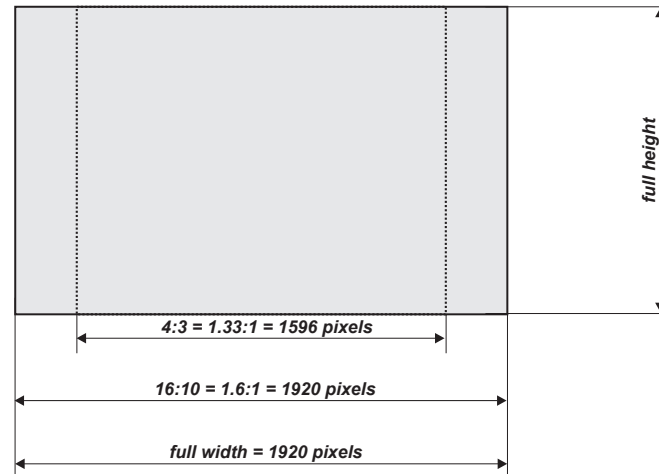

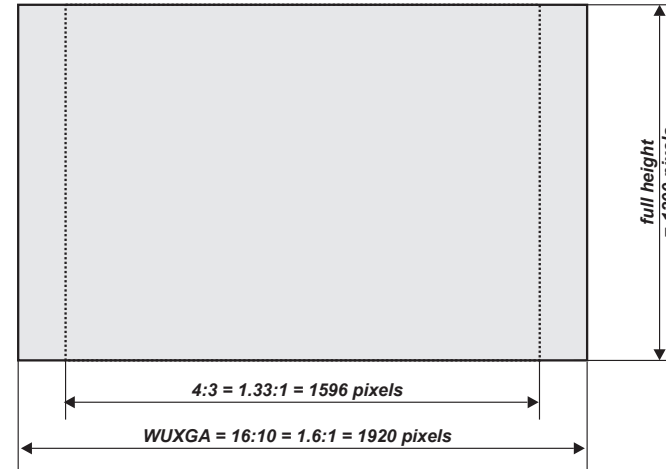
WUXGA images displayed full height**Notes****Diagonal screen sizes**

Screen sizes are sometimes specified by their diagonal size (D). When dealing with large screens and projection distances at different aspect ratios, it is more convenient to measure screen width (W) and height (H).

The example calculations below show how to convert diagonal sizes into width and height, at various aspect ratios.

2.35:1 (Scope)

$$W = D \times 0.92 \quad H = D \times 0.39$$

1.85:1

$$W = D \times 0.88 \quad H = D \times 0.47$$

16:9 = 1.78:1

$$W = D \times 0.87 \quad H = D \times 0.49$$

16:10 = 1.6:1 (native aspect ratio for WUXGA projectors)

$$W = D \times 0.85 \quad H = D \times 0.53$$

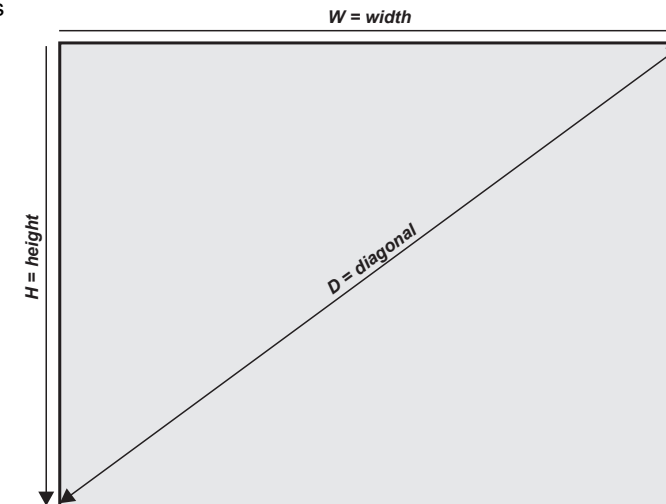

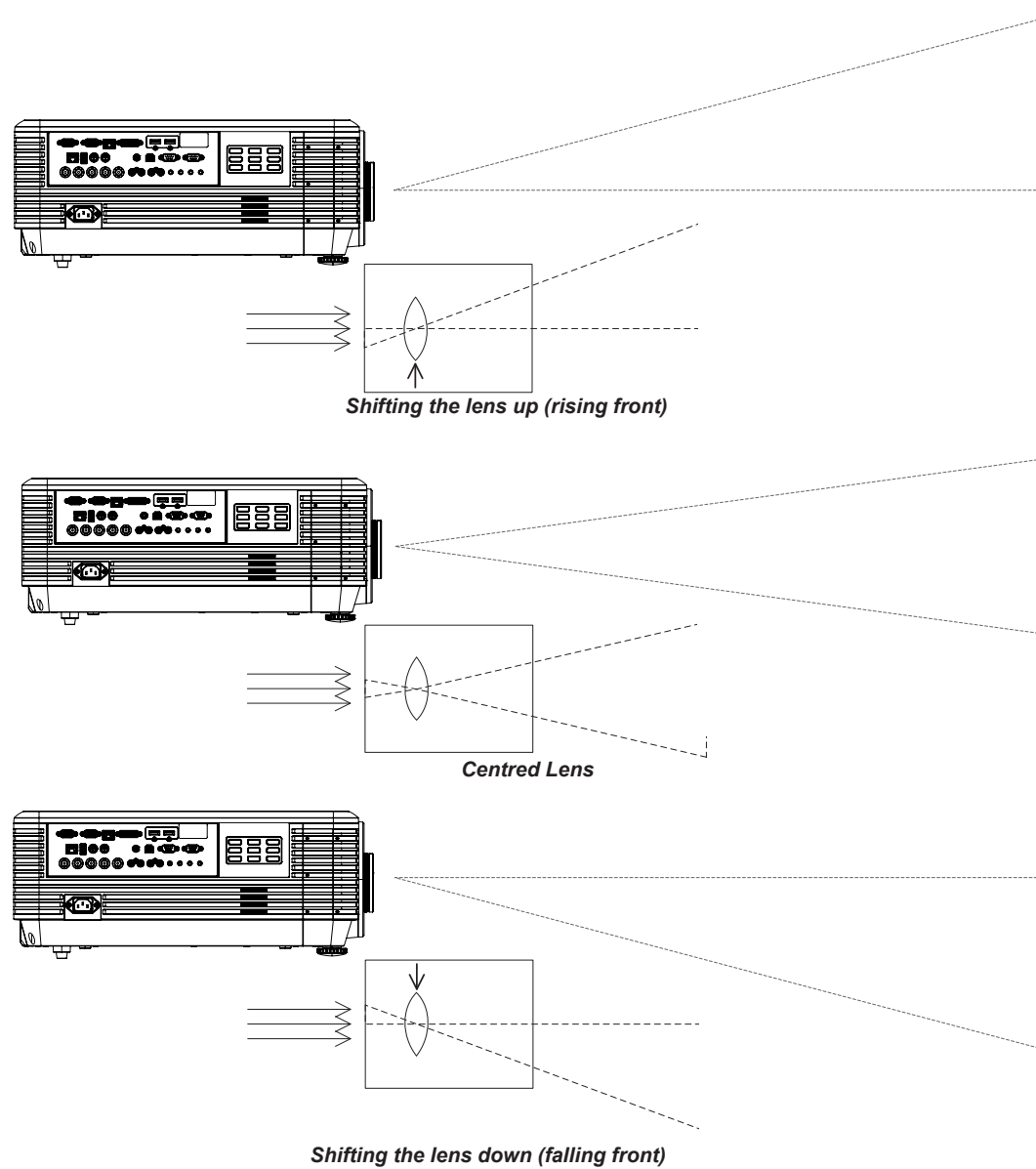

Positioning the image

The normal position for the projector is at the centre of the screen. However, you can set the projector above or below the centre, or to one side, and adjust the image using the **Lens shift** feature (known as **rising and falling front**) to maintain a geometrically correct image.



Notes

-  See *Lens control* on page 1 for more information on shifting the lens.
-  Whenever possible, position the projector so that the lens is centered for the highest quality image

Any single adjustment outside the ranges specified on the following page may result in an unacceptable level of distortion, particularly at the corners of the image, due to the image passing through the periphery of the lens optics.

If the lens is to be shifted in two directions combined, the maximum range without distortion will be somewhat less, as can be seen in the illustrations.

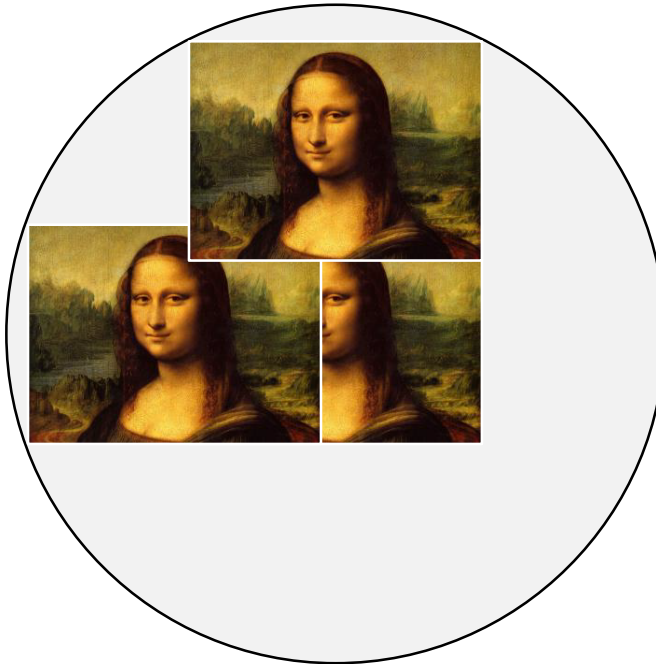

Full horizontal or vertical shift

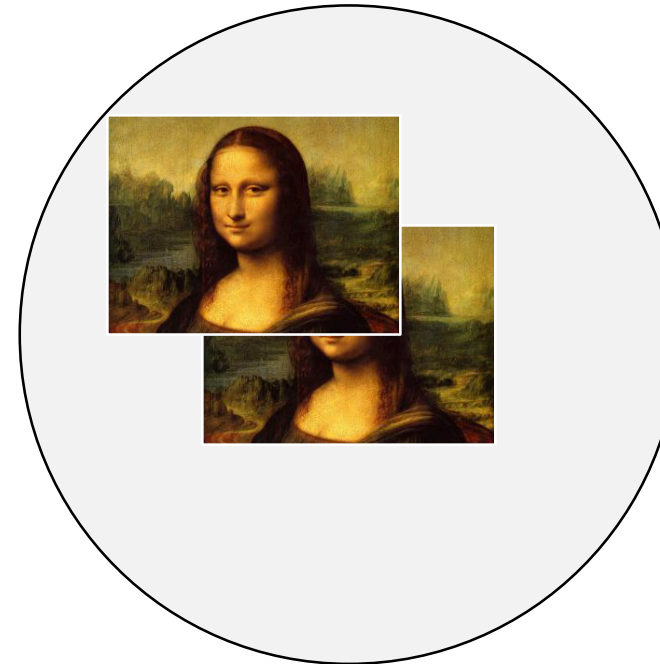

Combined shift is reduced

Notes



See *Lens control* on page 1 for more information on shifting the lens.

Aspect ratios explained

The appearance of a projected image on the screen depends on a combination of the following:

- The display resolution is **WUXGA** with a 1920 x 1200 resolution, corresponding to an aspect ratio of 16:10
- The aspect ratio of the input signal: usually **4:3**, **16:9** or **16:10**
- The value of the **Aspect Ratio** setting of the projector:
 - **16:9**, **4:3**, **16:10** and **5:4** stretch the image to the selected aspect ratio. **16:9** leaves black bars at the top and bottom of the screen (letterboxing effect); **4:3** and **5:4** leave black bars at the sides of the screen (pillarboxing).
 - **TheaterScope** is a special setting used in combination with an anamorphic lens, an optional accessory. It removes letterboxing from a 2.35:1 source packed into a 16:9 frame.
 - **Source** shows the image with its original aspect ratio, if this does not match the native aspect ratio of the DMD™, then the image will be scaled to either fit the full width or height of the display.

Aspect ratios examples

1. Unused screen areas

Source: 4:3

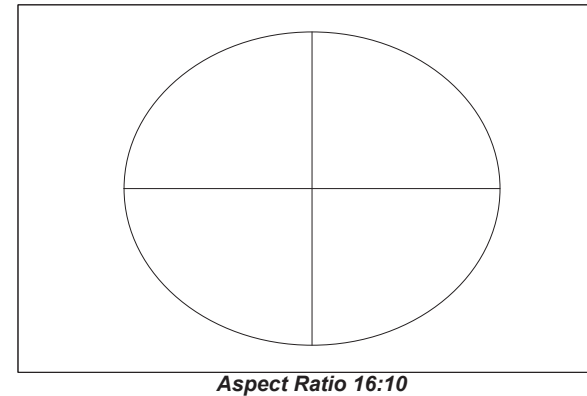
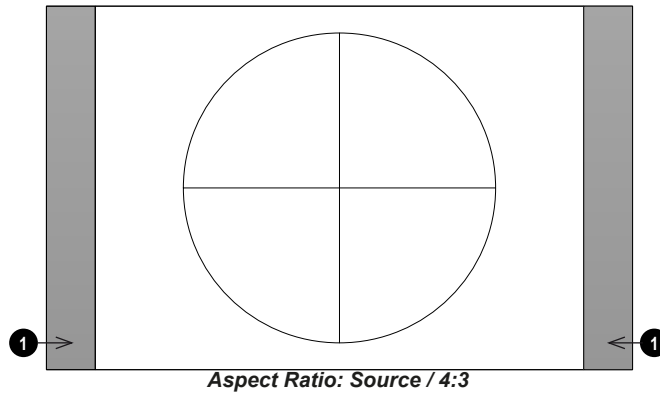

Notes

Source: 16:9

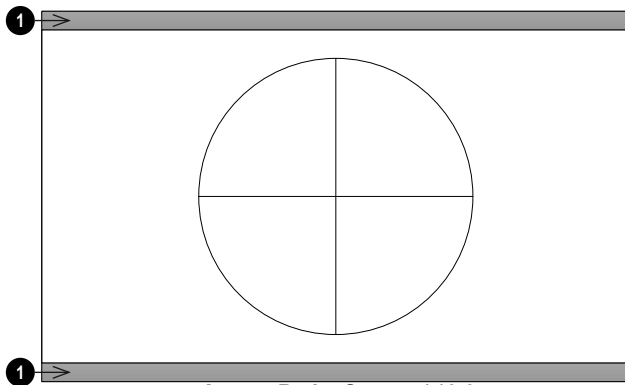

Aspect Ratio: Source / 16:9

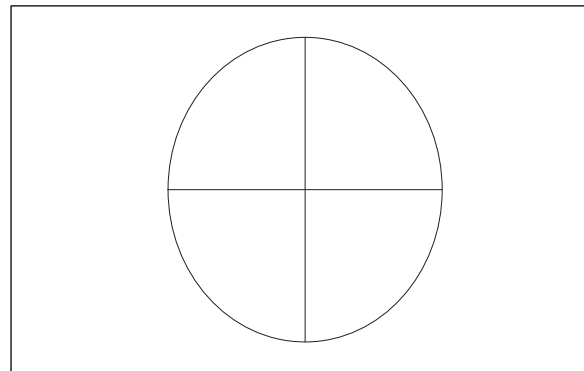

Aspect Ratio 16:10

Source: 16:10 (native)

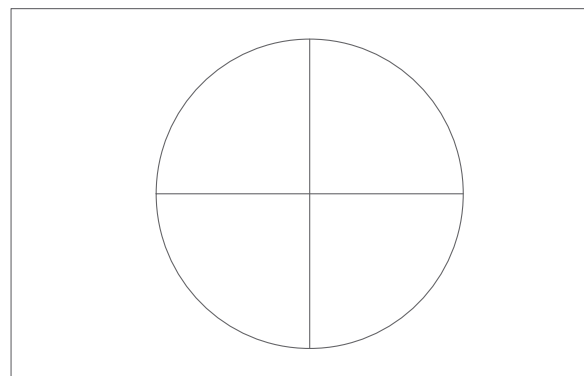

Aspect Ratio: Source / 16:10

Notes

Aspect ratio example: TheatreScope

The TheaterScope setting is used in combination with an anamorphic lens to restore 2.35:1 images packed into a 16:9 frame. Such images are projected with black lines at the top and bottom of the 16:9 screen to make up for the difference in aspect ratios.

Without an anamorphic lens and without the TheaterScope setting applied, a 16:9 source containing a 2.35:1 image looks like this:

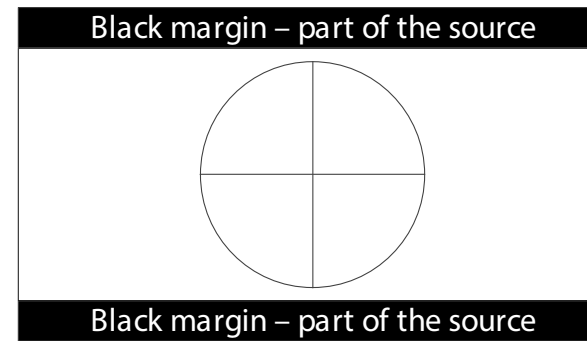

If we change the setting to TheaterScope, the black lines will disappear but the image will stretch vertically to reach the top and bottom of the DMD™:

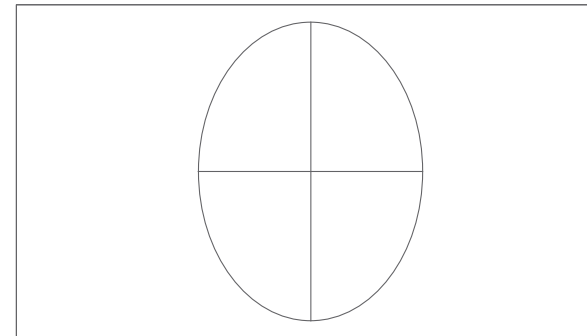

An anamorphic lens will stretch the image horizontally, restoring the original 2.35 ratio:

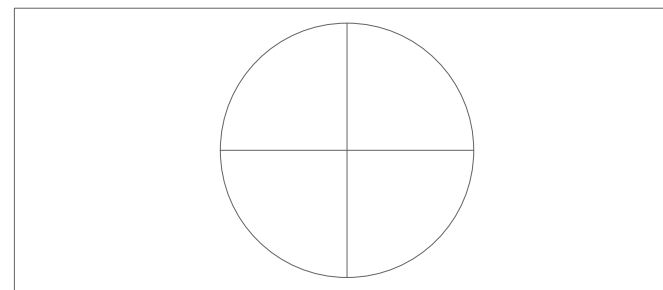

Notes

Appendix A: projector indicator messages

Power LED	Light LED	Temperature LED	Filter LED	Message
On Continuously	Off	Off	Off	Light source ready
On Continuously	Off	Off	On Continuously	Air filter replace warning
Flashing Continuously	Off	Off	Off	Starting up or cooling down
2 Flashes	Off	Off	Off	1W MCU detects scaler stops working
4 Flashes	1 Flash	Off	Off	G794 error
4 Flashes	2 Flashes	Off	Off	Laser driver board color wheel speed too low
4 Flashes	3 Flashes	Off	Off	Laser Driver board Phosphor wheel speed too low
4 Flashes	4 Flashes	Off	Off	Laser driver board 54V error
4 Flashes	5 Flashes	Off	Off	Laser driver board over temp
4 Flashes	6 Flashes	Off	Off	Laser driver board SCI error
4 Flashes	Off	On Continuously	Off	Thermal Break Sensor error
6 Flashes	1 Flash	Off	Off	FAN1 error
6 Flashes	2 Flashes	Off	Off	FAN2 error
6 Flashes	3 Flashes	Off	Off	FAN3 error
6 Flashes	4 Flashes	Off	Off	FAN4 error
6 Flashes	5 Flashes	Off	Off	FAN5 error
6 Flashes	6 Flashes	Off	Off	FAN6 error
6 Flashes	7 Flashes	Off	Off	FAN7 error
6 Flashes	8 Flashes	Off	Off	FAN8 error
6 Flashes	9 Flashes	Off	Off	FAN9 error
6 Flashes	10 Flashes	Off	Off	FAN10 error
7 Flashes	Off	Off	Off	Case open
7 Flashes	1 Flash	Off	Off	Lens open
8 Flashes	Off	Off	Off	DMD error
9 Flashes	Off	Off	Off	Color wheel error
9 Flashes	1 Flash	Off	Off	Phosphor wheel error
Off	1 Flash	On Continuously	Off	Over temperature T1
Off	2 Flashes	On Continuously	Off	Over temperature T2
Off	3 Flashes	On Continuously	Off	Over temperature T3
Off	4 Flashes	On Continuously	Off	Over temperature T4
Off	5 Flashes	On Continuously	Off	Over temperature T5

Notes

In the event of an error, please disconnect the AC power cord and wait for one (1) minute before restarting the projector.

 *If the Power or Light source LEDs are still flashing or the Over Temp LED is lit, Please contact your regional Digital Projection Ltd service center.*

Appendix B: supported signal input modes

Notes

2D formats

Signal Format	Resolution	H-Sync	V-Sync	Composite	Component	VGA/BNC	DVI-D	HDMI	HDBase-T	Remarks
		(KHz)	(Hz)	S Video		(Analog)	(Digital)	(Digital)	(Digital)	
NTSC		15.734	60	✓						
		15.625	50	✓						
	720 x 400	31.5	70.1			✓	✓	✓	✓	
	640 x 480	31.5	60			✓	✓	✓	✓	
	640 x 480	35	66.667			MAC13	MAC13	MAC13	MAC13	
	640 x 480	37.86	72.8				✓	✓	✓	
	640 x 480	37.5	75			✓	✓	✓	✓	
	640 x 480	43.3	85			✓	✓	✓	✓	
	640 x 480	61.9	119.5			✓	✓	✓	✓	
	800 x 600	37.9	60.3			✓	✓	✓	✓	
	800 x 600	46.9	75			✓	✓	✓	✓	
	800 x 600	48.1	72.2			✓	✓	✓	✓	
	800 x 600	53.7	85.1			✓	✓	✓	✓	
PAL/SECAM	800 x 600	76.3	120			✓	✓	✓	✓	
	832 x 624	49.722	74.546			✓	MAC16	MAC16	MAC16	
	1024 x 768	48.4	60			✓	✓	✓	✓	
	1024 x 768	56.5	70.1			✓	✓	✓	✓	
	1024 x 768	60.241	75.02			MAC19	MAC19	MAC19	MAC19	
	1024 x 768	60	75			✓	✓	✓	✓	
	1024 x 768	68.7	85			✓	✓	✓	✓	
	1024 x 768	97.6	120			✓	✓	✓	✓	
	1152 x 870	68.68	75.06			MAC21	MAC21	MAC21	MAC21	
	1280 x 720	45	60			✓	✓	✓	✓	
	1280 x 720	90	120			✓	✓	✓	✓	
	1280 x 768 (Reduce Blanking)	47.4	60			✓	✓	✓	✓	
	1280 x 768	47.8	59.9			✓	✓	✓	✓	

Signal Format	Resolution	H-Sync	V-Sync	Composite	Component	VGA/BNC	DVI-D	HDMI	HDBase-T	Remarks
		(KHz)	(Hz)	S Video		(Analog)	(Digital)	(Digital)	(Digital)	
PAL/SECAM	1280 x 800	49.7	59.8			✓	✓	✓	✓	
	1280 x 800	62.8	74.9			✓	✓	✓	✓	
	1280 x 800	71.6	84.9			✓	✓	✓	✓	
	1280 x 800	101.6	119.9			✓	✓	✓	✓	
	1280 x 1024	64	60			✓	✓	✓	✓	
	1280 x 1024	80	75			✓	✓	✓	✓	
	1280 x 1024	91.1	85			✓	✓	✓	✓	
	1280 x 960	60	60			✓	✓	✓	✓	
	1280 x 960	85.9	85			✓	✓	✓	✓	
	1400 x 1050	65.3	60			✓	✓	✓	✓	
	1440 x 900	55.9	59.9			✓	✓	✓	✓	
	1600 x 1200	75	60			✓	✓	✓	✓	
	1680 x 1050(Reduce Blanking)	64.67	59.88			✓	✓	✓	✓	
	1680 x 1050	65.29	59.95			✓	✓	✓	✓	
	1920 x 1080	67.5	60			✓	✓	✓	✓	
	1920 x 1200(Reduce Blanking)	74.038	59.95			✓	✓	✓	✓	
	1280 x 1024	130	120*					✓		*Reduce Blanking
	1400 x 1050	93.9	85					✓		
	1400 x 1050	133.3	120*					✓		*Reduce Blanking
	1440 x 900	114.2	120*					✓		*Reduce Blanking
	1600 x 1200	87.5	70					✓		
	1600 x 1200	93.8	75					✓		
	1600 x 1200	106.3	85					✓		
	1600 x 1200	152.4	120*					✓		*Reduce Blanking
1680 x 1050	82.3	75					✓			
1680 x 1050	93.9	85					✓			
1680 x 1050	133.4	120*					✓		*Reduce Blanking	

Notes

Signal Format	Resolution	H-Sync	V-Sync	Composite	Component	VGA/BNC	DVI-D	HDMI	HDBase-T	Remarks
		(KHz)	(Hz)	S Video		(Analog)	(Digital)	(Digital)	(Digital)	
PAL/SECAM	1920 x 1200	74.6	60					✓		
	1920 x 1200	94	75					✓		
	1920 x 1200	107.2	85					✓		
	3840 x 2160	53.946	23.976					✓	✓	
	3840 x 2160	54	24					✓	✓	
	3840 x 2160	56.25	25					✓	✓	
	3840 x 2160	67.5	30					✓	✓	
	3840 x 2160	112.5	50					✓	✓	
	3840 x 2160	135	60					✓	✓	
	4096 x 2160	54	24					✓		
	4096 x 2160	56.25	25					✓		
	4096 x 2160	67.5	30					✓		
	4096 x 2160	112.5	50					✓		
	4096 x 2160	135	60					✓		
	1080p	112.5	100					✓		
	1080p	135	120					✓		
SDTV	480i	15.734	60		✓		✓	✓	✓	
	576i	15.625	50		✓					
EDTV	576p	31.3	50		✓					
	480p	31.5	60		✓					
HDTV	720p	37.5	50		✓		✓	✓	✓	
	720p	45	60		✓		✓	✓	✓	
	1080i	33.8	60		✓		✓	✓	✓	
	1080i	28.1	50		✓		✓	✓	✓	
	1080p	27	24		✓		✓	✓	✓	
	1080p	28	25		✓					
	1080p	33.7	30		✓					
	1080p	56.3	50		✓					
1080p	67.5	60		✓						

Notes

3D formats

Signal Format	Resolution	H-Sync (KHz)	V-Sync (Hz)	Composite S Video	DVI-D (Digital)	HDMI 1/2	HDBase-T (Digital)	Remarks
NTSC	—	15.734	60	✓				
PAL/SECAM	640 x 480	31.5	60		✓	✓	✓	
	800 x 600	37.9	60.3		✓	✓	✓	Frame Sequential
	800 x 600	76.3	120		✓	✓	✓	Frame Sequential
	1024 x 768	48.4	60		✓	✓	✓	Frame Sequential
	1024 x 768	97.6	120		✓	✓	✓	Frame Sequential
	1280 x 720	45	60		✓	✓	✓	Frame Sequential
	1280 x 720	90	120		✓	✓	✓	Frame Sequential
	1280 x 768*	47.4	60		✓	✓	✓	*Reduce Blanking
	1280 x 768	47.8	59.9		✓	✓	✓	
	1280 x 800	49.7	59.8		✓	✓	✓	Frame Sequential
	1280 x 800	101.6	119.9		✓	✓	✓	Frame Sequential
	1280 x 1024	64	60		✓	✓	✓	
	1280 x 960	60	60		✓	✓	✓	
	1400 x 1050	65.3	60		✓	✓	✓	
	1440 x 900	55.9	59.9		✓	✓	✓	
	1600 x 1200	75	60		✓	✓	✓	
	1680 x 1050*	64.67	59.88		✓	✓	✓	*Reduce Blanking
	1680 x 1050	65.29	59.95		✓	✓	✓	
1920 x 1200*	74.038	59.95		✓	✓	✓	*Reduce Blanking	
1080p	112.5	100			✓			
1080p	135	120			✓			
SDTV	480i	15.734	60		✓	✓	✓	HQFS, Frame Sequential
HDTV	720p	37.5	50		✓	✓	✓	Frame Packing, Top / Bottom
	720p	45	60		✓	✓	✓	Frame Packing, Top / Bottom
	1080i	33.8	60		✓	✓	✓	Top / Bottom, Side-by-side
	1080i	28.1	50		✓	✓	✓	Top / Bottom, Side-by-side
	1080p	27	24		✓	✓	✓	Frame Packing, Top / Bottom

Notes

Appendix C: wiring details

Signal inputs and outputs

HDMI

19 way type A connector

1. TMDS Data 2+
2. TMDS Data 2 Shield (Ground)
3. TMDS Data 2-
4. TMDS Data 1+
5. TMDS Data 1 Shield (Ground)
6. TMDS Data 1-
7. TMDS Data 0+
8. TMDS Data 0 Shield (Ground)
9. TMDS Data 0-
10. TMDS Clock+
11. TMDS Clock Shield (Ground)
12. TMDS Clock-
13. CEC
14. not connected
15. SCL (DDC Clock)
16. SCA (DDC Data)
17. DDC/CEC Shield (Ground)
18. +5 V Power
19. Hot Plug Detect

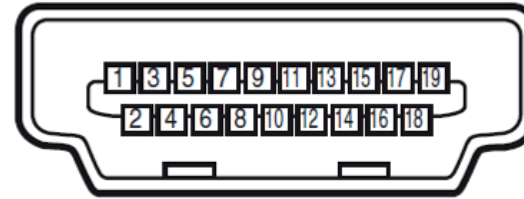

HDMI: pin view of panel connector

Notes

DisplayPort

DisplayPort 1.2

Pin 1	ML_Lane 0 (p)	Lane 0 (positive)
Pin 2	GND	Ground
Pin 3	ML_Lane 0 (n)	Lane 0 (negative)
Pin 4	ML_Lane 1 (p)	Lane 1 (positive)
Pin 5	GND	Ground
Pin 6	ML_Lane 1 (n)	Lane 1 (negative)
Pin 7	ML_Lane 2 (p)	Lane 2 (positive)
Pin 8	GND	Ground
Pin 9	ML_Lane 2 (n)	Lane 2 (negative)
Pin 10	ML_Lane 3 (p)	Lane 3 (positive)
Pin 11	GND	Ground
Pin 12	ML_Lane 3 (n)	Lane 3 (negative)
Pin 13	CONFIG1	Connected to Ground1
Pin 14	CONFIG2	Connected to Ground1
Pin 15	AUX CH (p)	Auxiliary Channel (positive)
Pin 16	GND	Ground
Pin 17	AUX CH (n)	Auxiliary Channel (negative)
Pin 18	Hot Plug	Hot Plug Detect
Pin 19	Return	Return for Power
Pin 20	DP_PWR	Power for connector (3.3 V 500 mA)

HDBaseT input

RJ45 socket.

1. DATA 0+
2. DATA 0-
3. DATA 1+
4. DATA 2+
5. DATA 2-
6. DATA 1-
7. DATA 3+
8. DATA 3-

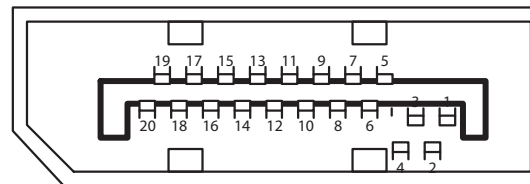

DisplayPort: pin view of panel connector

Notes

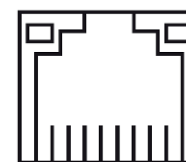

87654321

HDBase-T

DVI-D input

1. TMDS Data 2+
2. TMDS Data 2-
3. Ground
4. not connected
5. not connected
6. SCL
7. SDA
8. not connected
9. TMDS Data 1-
10. TMDS Data 1+
11. Ground
12. not connected
13. not connected
14. +5 V Power
15. Ground
16. HPD
17. TMDS Data 0-
18. TMDS Data 0+
19. Ground
20. not connected
21. not connected
22. Ground
23. TMDS Clock+
24. TMDS Clock-

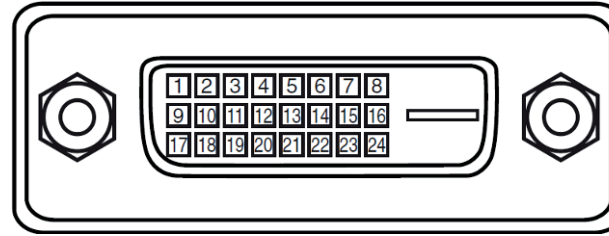

DVI-D: pin view of panel connector

Notes

VGA input

1. Red input
2. Green input
3. Blue input
4. not connected
5. not connected
6. Ground
7. Ground
8. Ground
9. +5 V Power
10. Ground
11. Ground
12. VGA_SDA
13. H-Sync
14. V-Sync
15. VGA_SCL
16. Ground

Control connections**LAN**

RJ45 socket

1. TX+
2. TX-
3. TXC
4. Ground
5. Ground
6. RXC
7. RX+
8. RX-

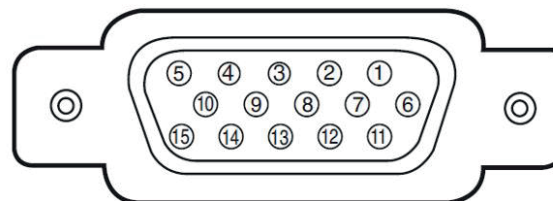
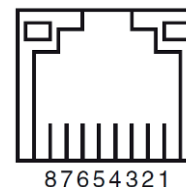
**VGA: pin view of panel connector****LAN: pin view of panel connector****Notes**

 Only one remote connection (RS232 or LAN) should be used at any one time.

RS232

9 way D-type connector

1. not connected
2. Received Data (RX)
3. Transmitted Data (TX)
4. not connected
5. Ground
6. not connected
7. Short with pin8
8. Short with pin7
9. not connected

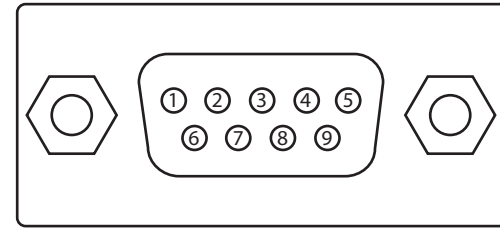

RS232: pin view of panel male connector

Trigger

3.5 mm mini jack, Output: 12V, 200 mA max

- **Tip** Signal
- **Sleeve** Ground

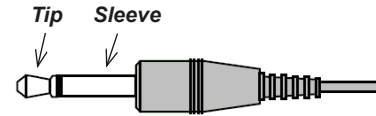

Notes

Appendix D: communication parameter setup and Control Protocol

You can use the serial control command to input commands for projector control or retrieve its operational data through Windows client terminal software.

Item	Parameter
Bit per Second	9600 bps
Data Bit	8-bit
Parity	None
Stop Bit	1
Flow Control	None

Operation commands

Operation command syntax:

An operation command is prefixed by character "op", followed by control commands and settings separated by space blank [SP], and ended by carriage return pair "CR" and "ASCII hex 0D". Syntax of serial control commands:

op[SP]<operation command>[SP]<Setting Value>[CR]

- **op.** A constant indicating this is an operation command.
- **[SP].** Indicate one blank space.
- **[CR].** Indicate the command ending carriage return pair "CR" and "ASCII hex 0D".
- **Setting value.** Settings of operation command

Types of setup strings	Characters of settings	Description
Query current setup	?	Question mark "?" indicates querying current setup
Setup	= <settings>	Syntax: Symbol "=" suffixed with setup values
Increase setup order of adjustment items	+	Some settings are changed in steps. Symbol "+" indicates changing one step up
Decrease setup order of adjustment items	-	Some settings are changed in steps. Symbol "-" indicates changing one step down
Execute operation command	None	Certain operation commands execute after input without further setting or regulators.

Examples:

Control items	Input command row	Projector return message
Execute command	reset.all[CR]	RESET.ALL
Query current brightness	op bright ?[CR]	OP BRIGHT = 50
Set up brightness	op bright = 100[CR]	OP BRIGHT = 100
Brightness value + 1	op bright +[CR]	OP BRIGHT = "new value"
Brightness value - 1	op bright -[CR]	OP BRIGHT = "new value"
Out of range or not support	op bright = 200[CR]	OP BRIGHT = NA
Illegal command	op abright = 100[CR]	*Illegal format#

Notes



When sending the multiple commands, make sure the return message of the last command is received before sending out the next one.

Function	Operation	Set	Get	Inc	Dec	EXE	Values	Notes
Auto Source	auto.src	V	V				0 : Off 1 : On	
HDMI Color Space	color.space	V	V				0 : Auto 1 : RGB 2 : YUV	
HDMI Range	hdmi.range	V	V				0 : Auto 1 : Full 2 : Limited	
Video AGC	video.agc	V	V				0 : Off 1 : On	
Video Saturation	video.saturation	V	V	V	V		0 ~ 100	
Video Tint	video.tint	V	V	V	V		0 ~ 100	
Closed Caption	cc	V	V				0 : Off 1 : On	
H Position	h.pos	V	V	V	V		-5 ~ +5 -100 ~ +100(Auto Sync Off)	
V Position	v.pos	V	V	V	V		-5 ~ +5 -100 ~ +100(Auto Sync Off)	
Phase	phase	V	V	V	V		0 ~ 31	
clock	clock	V	V	V	V		-5 ~ +5	
Auto Sync	auto.sync	V	V				0 : Off 1 : On	
HDBaseT Control	hdbaset	V	V				0 : Off 1 : On	
3D	threed	V	V				0 : Off 1 : DLP-Link 2 : IR	
3D Sync Invert	threed.syncinvert	V	V				0 : Off 1 : On	

Function	Operation	Set	Get	Inc	Dec	EXE	Values
3D Format	threed.format	V	V				0 : Frame Sequential 1 : Top / Bottom 2 : Side by side 3 : Frame Packing 4 : Auto
3D Sync Out Delay	threed.syncdelay	V	V				0 ~ 359
3D Sync Input	threed.syncinput		V				0 : Internal 1 : External
3D Sync Output	threed.syncoutput	V	V				0 : Internal 1 : Bypass
Picture Mode	pic.mode	V	V				0 : Presentation 1 : Bright 2 : Game 3 : Movie 4 : Vivid 5 : TV 6 : sRGB 8 : DICOM 9 : User 1 10 : User 2 11 : HDR
Brightness	bright	V	V	V	V		0 ~ 100
Contrast	contrast	V	V	V	V		0 ~ 100
HDR Control	hdr.control	V	V				0 : Off 1 : Auto 2 : On
HDR Mode	hdr.mode	V	V				0 : PQ-L300 1 : PQ-L400 2 : PQ-L500 3 : PQ-L600

Notes

Function	Operation	Set	Get	Inc	Dec	EXE	Values	Notes
Dynamic Black	dblack	V	V				0 : Off 1 : On	
Projector Light	projector.light	V	V				0 : Disable 1 : 0.5 sec 2 : 1 Sec 3 : 2 Sec 4 : 3 Sec 5 : 4 Sec	
HSG/Red Gain	hsg.r.gain	V	V	V	V		0 ~ 100	
HSG/Green Gain	hsg.g.gain	V	V	V	V		0 ~ 100	
HSG/Blue Gain	Hsg.b.gain	V	V	V	V		0 ~ 100	
HSG/Cyan Gain	hsg.c.gain	V	V	V	V		0 ~ 100	
HSG/Magenta Gain	hsg.m.gain	V	V	V	V		0 ~ 100	
HSG/Yellow Gain	hsg.y.gain	V	V	V	V		0 ~ 100	
HSG/Red/Saturation	hsg.r.sat	V	V	V	V		0 ~ 100	
HSG/Green/Saturation	hsg.g.sat	V	V	V	V		0 ~ 100	
HSG/Blue/Saturation	Hsg.b.sat	V	V	V	V		0 ~ 100	
HSG/Cyan/Saturation	hsg.c.sat	V	V	V	V		0 ~ 100	
HSG/Magenta/Saturation	hsg.m.sat	V	V	V	V		0 ~ 100	
HSG/Yellow/Saturation	Hsg.y.sat	V	V	V	V		0 ~ 100	
HSG/Red/Hue	hsg.r.hue	V	V	V	V		0 ~ 100	
HSG/Green/Hue	hsg.g.hue	V	V	V	V		0 ~ 100	
HSG/Blue/Hue	Hsg.b. hue	V	V	V	V		0 ~ 100	
HSG/Cyan/Hue	hsg.c. hue	V	V	V	V		0 ~ 100	
HSG/Magenta/Hue	hsg.m. hue	V	V	V	V		0 ~ 100	
HSG/Yellow/Hue	Hsg.y. hue	V	V	V	V		0 ~ 100	
HSG/White/Red Gain	hsg.wr.gain	V	V	V	V		0 ~ 100	
HSG/White/Green Gain	hsg.wg.gain	V	V	V	V		0 ~ 100	
HSG/White/Blue Gain	Hsg.wb.gain	V	V	V	V		0 ~ 100	
Brilliant Color	bri.color	V	V	V	V		0 ~ 10	
Sharpness	sharp	V	V	V	V		0 ~ 31	

Function	Operation	Set	Get	Inc	Dec	EXE	Values
Gamma	gamma	V	V				0 : 1.8 1 : 2.0 2 : 2.2 3 : 2.4 4 : B&W 5 : Linear
Color Temperature	color.temp	V	V				0 : Warm 1 : Normal 2 : Cold
White Balance /Red Offset	red.offset	V	V	V	V		-100 ~ +100
White Balance /Green Offset	green.offset	V	V	V	V		-100 ~ +100
White Balance /Blue Offset	blue.offset	V	V	V	V		-100 ~ +100
White Balance /Red Gain	red.gain	V	V	V	V		0 ~ 200
White Balance /Green Gain	green.gain	V	V	V	V		0 ~ 200
White Balance /Blue Gain	blue.gain	V	V	V	V		0 ~ 200
Aspect Ratio	aspect	V	V				0 : Fill 1 : 4:3 2 : 16:9 3 : LetterBox 4 : Native 5 : 2.35:1
Digital Zoom	zoom	V	V				-10 ~ +10
V Keystone	v.keystone	V	V	V	V		-30 ~ +30
H Keystone	h.keystone	V	V	V	V		-25 ~ +25
H Image Shift	img.hshift	V	V	V	V		-50 ~ +50
V Image Shift	img.vshift	V	V	V	V		-50 ~ +50
Projection	projection	V	V				0 : Front 1 : Rear 2 : Ceiling 3 : Rear + Ceiling

Notes

Function	Operation	Set	Get	Inc	Dec	EXE	Values	Notes
Direct Power On	direct.poweron	V	V				0 : Off 1 : On	
Light Mode	light.mode	V	V				0 : Normal (100%) 1 : Eco (80%) 2 : Eco Plus 3 : Dimming 4 : Extre Diming 5 : Custom Light	
Custom Light	custom.light	V	V				50 ~ 200	
Fan Speed	fanspeed	V	V				0 : Normal 1 : High	
IR Control	ir.control	V					0 : Both IR On 1 : Front IR On 2 : Rear IR On	
Remote ID	remote.id	V	V				0 : Default(ID0) 1 : ID1 2 : ID2 3 : ID3 4 : ID4 5 : ID5 6 : ID6 7 : ID7	
NetWork Status	net.status		V				0 : Disconnect 1 : Connected	
NetWork / DHCP	net.dhcp	V	V				0 : Off 1 : On	
NetWork / IP Address	net.ipaddr	V	V				<string>	
NetWork / Subnet	net.subnet	V	V				<string>	
NetWork / Gateway	net.gateway	V	V				<string>	
NetWork / DNS	net.dns	V	V				<string>	
NetWork Apply	net.apply	V					0 : Cancel 1 : OK	

Function	Operation	Set	Get	Inc	Dec	EXE	Values
Standby Power	standby.power	V	V				1 : On (0.5W) 2 : On By Lan 3 : On By HDBaseT
No Signal Power Off	nosignal.poweroff	V	V				0 ~ 36
Sleep Timer	sleep.timer	V	V				0 ~ 120
Volume	volume	V	V				0 ~ 10
Air Filter Hours	airfilter.hours		V				<string>
Air Filter Hour Reset	airfilter.reset					V	
Blank Screen Color	blankscreen.color	V	V				0 : Black 1 : Red 2 : Green 3 : Blue 4 : White
Logo	logo	V	V				0 : Std. 1 : Black 2 : Blue
MENU Position	menu.position	V	V				0 : Left 1 : Right 2 : Center 3 : Down 4 : Up
MENU Translucent	menu.trans	V	V				0 : Off 1 : 25% 2 : 50% 3 : 75% 4 : 100%
Keypad Lock	keypad.lock	V	V				0 : Off 1 : On

Notes

Function	Operation	Set	Get	Inc	Dec	EXE	Values	Notes
Language	lang	V	V				0 : English 1 : French 2 : German 3 : Spanish 4 : Portuguese 5 : Simplified Chinese 6 : Traditional Chinese 7 : Italian 8 : Norwegian 9 : Swedish 10 : Dutch 11 : Russian 12 : Polish 13 : Finnish 14 : Greek 15 : Korean 16 : Hungarian 17 : Czech 18 : Arabic 19 : Turkish 20 : Vietnamese 21 : Japanese 22 : Thai 23 : Farsi 24 : Hebrew 25 : Danish 26 : French Canadian	

Function	Operation	Set	Get	Inc	Dec	EXE	Values
Reset All	reset.all					V	
Source Info	source.info		V				<string>
Light Hours 1	light1.hours		V				<string>
Software Version	sw.ver		V				<string>
Serial Number	ser.no		V				<string>
Auto Image	auto.img					V	
Light 1 Status	light1.stat		V				0 : Off 1 : On
Model	model		V				<string>
Pixel Clock	pixel.clock		V				<string>
H Refresh Rate	h.refresh		V				<string>
V Refresh Rate	v.refresh		V				<string>
Blank	blank	V	V				0 : Off 1 : On
Power On	power.on					V	
Power Off	power.off					V	
Projector Status	status		V				0 : Reset 1 : Standby 2 : Active 3 : cooling 4 : Warming 5 : Power Up
Mute	mute	V	V				0 : Off 1 : On
Freeze	freeze	V	V				0 : Off 1 : On
Input Select	input.sel	V	V				1 : RGB 3 : DVI 4 : Video 6 : HDMI 1 7 : BNC 9 : HDMI 2 15 : HDBaseT

Notes

Appendix E: glossary of terms*Notes***1****1080p**

An HDTV resolution which corresponds to 1920 x 1080 pixels (a widescreen aspect ratio of 16:9).

3**3D active glasses**

Wireless battery-powered glasses with LCD shutters. Synchronization information is communicated to the glasses by means of an infrared (IR) or radio frequency (RF) emitter which is connected to the Sync Out terminal on the projector. IR or RF pulses are transmitted by the emitter to signal when the left eye and right eye images are being displayed. The glasses incorporate a sensor which detects the emitter's signal and synchronises the left and right eye shutters with the projected image.

3D passive glasses

Passive glasses do not require a power source to work. Light with left-hand polarisation can pass through the left lens and light with right hand polarisation can pass through the right-hand lens. These glasses are used in conjunction with another device which polarizes the image, such as a ZScreen.

4**4K-UHD**

The 4K-UHD resolution of 3840 × 2160 is the dominant 4K resolution used in the consumer media and display industries. This resolution has an aspect ratio of 16 :9, with 8,294,400 total pixels.

A**Adjust lines**

A pattern applied to the image where its edge is to be blended with another image. Adjust lines are used to position the projectors in the array during the edge blend process.

Anamorphic lens

A special lens which, when used with the TheaterScope aspect ratio, allows watching 2.35:1 content packed in a 16:9 source.

Aperture

The opening of the lens that determines the angle through which light travels to come into focus.

Aspect ratio

The proportional relationship between the width and the height of the projected image. It is represented by two numbers separated by a colon, indicating the ratio of image width and height respectively: for example, 16:9 or 2.35:1. Not to be confused with resolution.

B**Blanking (projection)**

The ability to intentionally turn off, that is, set to black, areas around the edges of the projected image. It is sometimes referred to as “curtains” since it can be used to blank an area of image that literally falls on the curtains at the side of the screen in a movie theater. Usually no image resizing or geometric correction takes place and the “blanked” part of the image is lost. Not to be confused with horizontal and vertical blanking (video signal).

Blanking (video signal)

The section of the video signal where there is no active video data. Not to be confused with blanking (projection).

Blend region

The area of the image that is to overlap with another image in an edge blend setup. Sometimes called overlapping region.

Brightness (electronic control)

A control which adds a fixed intensity value to every pixel in the display, moving the entire range of displayed intensities up or down, and is used to set the black point in the image (see Contrast). In Component Video signals, brightness is the same as luminance.

Brightness (optical)

Describes how ‘bright’ an image that is projected onto a screen appears to an observer.

C**C**

Also known as ‘C’, this is the component, or pair of components, of a Component Video signal which describes color difference information.

Chrominance

Also known as ‘C’, this is the component, or pair of components, of a Component Video signal which describes color difference information.

Color difference

In Component Video signals, the difference between specified colors and the luminance component. Color difference is zero for monochrome images.

Color gamut

The spectrum of color available to be displayed.

Color temperature

The position along the black body curve on the chromaticity diagram, normally quoted in Kelvin. It takes into account the preset values for color balance in the service set-up to take up the variations in the prism. The projector allows you to adjust this temperature (i.e. adjust the picture color temperature).

Notes

Component video

A three-wire or four-wire video interface that carries the signal split into its basic RGB components or luminance (brightness) and two-color difference signals (YUV) and synchronization signals.

Contrast (electronic control)

The adjustment of the white point of the image without affecting the black point. This increases the intensity range of the displayed image.

Contrast (optical)

The intensity difference between the darkest and lightest areas of the screen.

Cr, Cb

Color difference signals used with 'Y' for digital Component Video inputs. They provide information about the signal color. Not to be confused with Pr, Pb.

Crop

Remove part of the projected image. Alternatively, fit an image into a frame with a different aspect ratio by removing part of the image. The image is resized so that either its length or its width equals the length or width of the frame, while the other dimension has moved outside the frame; the excess area is then cut out.

D**Dark time**

The time inserted between frames when using 3D active glasses, to avoid ghosting caused by switching time between left and right eye.

DDC (Display Data Channel)

A communications link between the source and projector. DDC is used on the HDMI, DVI and VGA inputs. The link is used by the source to read the EDID stored in the projector.

Deinterlacing

The process of converting interlaced video signals into progressive ones.

DHCP (Dynamic Host Configuration Protocol)

A network protocol that is used to configure network devices so that they can communicate on an IP network, for example by allocating an IP address.

DMD™ (Digital Micromirror Device™)

The optical tool that transforms the electronic signal from the input source into an optical image projected on the screen. The DMD™ of a projector has a fixed resolution, which affects the aspect ratio of the projected image. A Digital Micromirror Device™ (DMD™) consists of moving microscopic mirrors. Each mirror, which acts as a pixel, is suspended between two posts by a thin torsion hinge. It can be tilted to produce either a bright or dark pixel.

E

Edge blend

A method of creating a combined image by blending the adjoining edges of two or more individual images.

Edge tear

An artifact observed in interlaced video where the screen appears to be split horizontally. Edge tears appear when the video feed is out of sync with the refresh rate of the display device.

EDID (Extended Display Identification Data)

Information stored in the projector that can be read by the source. EDID is used on the HDMI, DVI and VGA inputs, allowing the source to automatically configure to the optimum display settings.

EDTV (Enhanced Definition Television)

A progressive digital television system with a lower resolution than HDTV.

F

Field

In interlaced video, a part of the image frame that is scanned separately. A field is a collection of either all the odd lines or all the even lines within the frame.

Frame

One of the many still images displayed in a sequence to create a moving picture. A frame is made of horizontal lines of pixels. For example, a 1920x1080 frame consists of 1080 lines, each containing 1920 pixels. In analog video frames are scanned one at a time (progressive scanning) or split into fields for each field to be scanned separately (interlaced video).

Frame rate

The number of frames shown per second (fps). In TV and video, a frame rate is the rate at which the display device scans the screen to “draw” the frame.

Frame rate multiplication

To stop low frame rate 3D images from flickering, frame rate multiplication can be used, which increases the displayed frame rate by two or three times

G

Gamma

A nonlinear operation used to code and decode luminance. It originates from the Cathode Ray Tube technology used in legacy television sets.

Ghosting

An artifact in 3D image viewing. Ghosting occurs when an image intended for one eye is partially seen by the other eye. Ghosting can be removed by optimizing the dark time and sync delay.

Notes

H

HDCP (High-bandwidth Digital Content Protection)

An encryption scheme used to protect video content.

HDTV (High Definition Television)

A television system with a higher resolution than SDTV and EDTV. It can be transmitted in various formats, notably 1080p and 720p.

Hertz (Hz)

Cycles per second.

Horizontal Scan Rate

The rate at which the lines of the incoming signal are refreshed. The rate is set by the horizontal synchronization from the source and measured in Hertz.

Hs + Vs

Horizontal and vertical synchronization.

Hue

The graduation (red/green balance) of color (applicable to NTSC).

I

Interlacing

A method of updating the image. The screen is divided in two fields, one containing every odd horizontal line, the other one containing the even lines. The fields are then alternately updated. In analog TV interlacing was commonly used as a way of doubling the refresh rate without consuming extra bandwidth.

Interleaving

The alternation between left and right eye images when displaying 3D.

L

LED (Light Emitting Diode)

An electronic component that emits light.

Letterboxing

Black margins at the top and bottom of the image. Letterboxing appears when a wider image is packed into a narrower frame without changing the original aspect ratio.

Notes

Lumen

A photometric unit of radiant power. For projectors, it is normally used to specify the total amount of emitted visible light.

Luminance

Also known as 'Y', this is the part of a Component Video signal which affects the brightness, i.e. the black and white part.

N

Noise

Electrical interference displayed on the screen.

NTSC (National Television Standards Committee)

The United States standard for television - 525 lines transmitted at 60 interlaced fields per second

O

OSD (on-screen display)

The projector menus allowing you to adjust various settings.

Overlapping region

The area of the image that is to overlap with another image in an edge blend setup. Sometimes called overlapping region.

P

PAL (Phase Alternate Line)

The television system used in the UK, Australia and other countries - 625 lines transmitted at 50 interlaced fields per second.

Pillarboxing

Black margins at the left and right of the image. Pillarboxing appears when a narrower image is packed into a wider frame without changing the aspect ratio.

Pixel

Short for Picture Element. The most basic unit of an image. Pixels are arranged in lines and columns. Each pixel corresponds to a micromirror within the DMD™; resolutions reflect the number of pixels per line by the number of lines. For example, a 1080p projector contains 1080 lines, each consisting of 1920 pixels.

Pond of mirrors

Area around the periphery of the DMD™ containing inactive mirrors. The pond of mirrors may cause artifacts, for example during the edge blending process.

Notes

Pr, Pb

Color difference signals used with 'Y' for analog Component Video inputs. They provide information about the signal color. Not to be confused with Cr, Cb.

Primary colors

Three colors any two of which cannot be mixed to produce the third. In additive color television systems the primary colors are red, green and blue.

Progressive scanning

A method of updating the image in which the lines of each frame are drawn in a sequence, without interlacing.

Pulldown

The process of converting a 24 fps film footage to a video frame rate (25 fps for PAL/SECAM, 30 fps for NTSC) by adding extra frames. DP projectors automatically carry out reverse pulldown whenever possible.

R**Resolution**

The number of pixels in an image, usually represented by the number of pixels per line and the number of lines (for example, 1920 x 1200).

RGB (Red, Green and Blue)

An uncompressed Component Video standard.

S**Saturation**

The amount of color in an image.

Scope

An aspect ratio of 2.35:1.

SDTV (Standard Definition Television)

An interlaced television system with a lower resolution than HDTV. For PAL and SECAM signals, the resolution is 576i; for NTSC it is 480i.

SECAM (Sequential Color with Memory)

The television system used in France, Russia and some other countries - 625 lines transmitted at 50 interlaced fields per second.

Smooth picture

A feature that can display a higher resolution source than the native resolution of the projector without losing any pixel data.

SX+

A display resolution of 1400 x 1050 pixels with a 4:3 screen aspect ratio. (Shortened from SXGA+, stands for Super Extended Graphics Array Plus.)

Synchronization

A timing signal used to coordinate an action.

T

Test pattern

A still image specially prepared for testing a projection system. It may contain various combinations of colors, lines and geometric shapes.

TheaterScope

An aspect ratio used in conjunction with a special anamorphic lens to display 2.35:1 images packed into a 16:9 frame.

Throw distance

The distance between the screen and the projector.

Throw ratio

The ratio of the throw distance to the screen width.

TRC (Throw ratio correction)

A special number used in calculating throw distances and throw ratios when the image does not fill the width of the DMD™. TRC is the ratio of the DMD™ aspect ratio to the image source aspect ratio: $TRC = \text{DMD}^{\text{TM}} \text{ aspect ratio} / \text{Source aspect ratio}$ TRC is only used in calculations if it is greater than 1.

U

UXGA

A display resolution of 1600 x 1200 pixels with a 4:3 screen aspect ratio. (Stands for Ultra Extended Graphics Array.)

V

Vertical Scan Rate

The rate at which the frames of the incoming signal are refreshed. The rate is set by the vertical synchronization from the source and measured in Hertz.

Vignetting

Optical cropping of the image caused by the components in the projection lens. This can happen if too much offset is applied when positioning the image using the lens mount.

Vista

An aspect ratio of 1.66:1.

Notes

W

WUXGA

A display resolution of 1920 x 1200 pixels with a 16:10 screen aspect ratio. (Stands for Widescreen Ultra Extended Graphics Array.)

Y

Y

This is the luminance input (brightness) from a Component Video signal.

YUV

Color difference signals used with 'Y' for analog Component Video inputs. They provide information about the signal color. Not to be confused with Cr, Cb.

Z

ZScreen

A special kind of light modulator which polarizes the projected image for 3D viewing. It normally requires that images are projected onto a silver screen. The ZScreen is placed between the projector lens and screen. It changes the polarization of the projected light and switches between left- and right-handed circularly polarized light at the field rate.

Notes

DIGITAL PROJECTION

A Delta Associate Company

Contact Information:

Europe

Digital Projection Limited
Greenside Way, Middleton,
Manchester, M24 1XX, UK
Registered in England No.
2207264
Registered Office: As Above
Tel: (+44) 161 947 3300
Fax: (+44) 161 684 7674
enquiries@digitalprojection.co.uk
service@digitalprojection.co.uk
www.digitalprojection.co.uk

North America

Digital Projection Inc.
55 Chastain Road, Suite 115,
Kennesaw, GA 30144, USA
Tel: (+1) 770 420 1350
Fax: (+1) 770 420 1360
powerinfo@digitalprojection.com
www.digitalprojection.com

China

Digital Projection China
中国北京市朝阳区芍药居北
里101号世奥国际中心A座2301
室(100029)
Rm A2301, ShaoYaoJu 101 North
Lane, Shi Ao International Center,
Chaoyang District, Beijing 100029,
PR CHINA
Tel: (+86) 10 84888566
Fax: (+86) 10 84888566-805
techsupport@dp-china.com.cn
www.dp-china.com.cn

Dubai

Digital Projection FZE
Unit B4, Light Industrial Units 4,
Silicon Oasis, Dubai, UAE
Tel: +971 43300800
enquiries@digitalprojection.co.uk
www.digitalprojection.com

Japan

Digital Projection Japan
〒105-0012 東京都港区芝大門
2-1-14
2-1-14 Shibadaimon, Minato-ku,
Tokyo, Japan 105-0012
japan@digitalprojection.co.uk
www.digitalprojection.com/jp

Taiwan

Digital Projection Taiwan
186 Ruey Kuang Rd, Neihu
District, Taipei, 114 Taiwan
Tel: +886-8797-2088 x8854
Taiwan@digitalprojection.co.uk

Korea

Digital Projection Korea
1511, Byucksan Digital Valley 6-
cha, Gasan-dong, Geumcheon-
gu, Seoul, Korea
Tel: (+82) 2 515 5303 #1417
Korea@digitalprojection.co.uk

India

Digital Projection India
Plot-43, Sector-35, HSIIDC,
Gurgaon Haryana -122001
Tel: +91-124-4874900#4275
india@digitalprojection.co.uk