

MIMO88SG / 1212SG

DIGITAL MATRIXES

Installation Digital Matrix



USER MANUAL

INDEX

| | |
|---|--------------|
| HARDWARE | 3-20 |
| 1. IMPORTANT REMARK..... | 3 |
| 2. IMPORTANT SAFETY INSTRUCTIONS | 3 |
| 3. IMPORTANT NOTE..... | 5 |
| 4. INTRODUCTION..... | 5 |
| 5. INSTALLATION..... | 6 |
| 5.1. Location, assembly, ventilation | 6 |
| 5.2. Connection to an AC outlet and switching on | 6 |
| 5.3. Signal input connections..... | 7 |
| 5.4. Audio Output Connections..... | 7 |
| 5.5. ETHERNET port for programming and control..... | 8 |
| 5.5.1 Factory Preset Network settings..... | 8 |
| 5.6. REMOTE port for digital remote controls..... | 8 |
| 5.7. GPI Remote Control Ports..... | 9 |
| 5.8. Remote control RS-232 Port..... | 10 |
| 5.9. Front panel controls and LED indicators | 10 |
| 6. CLEANING..... | 10 |
| 7. FUNCTION LIST..... | 11 |
| 8. FUNCTION DIAGRAMS | 12 |
| 8.1 MIMO88SG..... | 12 |
| 8.2 MIMO1212SG | 13 |
| 9. TECHNICAL CHARACTERISTICS | 14 |
| 9.1. MIMO88SG..... | 14 |
| 9.2. MIMO1212SG | 16 |
| 10. BLOCK DIAGRAMS | 19 |
| 10.1. MIMO88SG..... | 19 |
| 10.2. MIMO1212SG..... | 20 |
| SOFTWARE | 22-31 |
| 11. TP-NET PROTOCOL INTRODUCTION..... | 22 |
| 12. MIMO88SG / MIMO1212SG (SINGLE) DIGITAL MATRIX..... | 25 |
| 13. MIMO88SG CONFERENCE DIGITAL MATRIX..... | 30 |
| 14. ERROR CODES FOR ECLERNET DEVICES..... | 31 |
| 14.1. COMMON ERROR CODES (to all EclerNet - TP-NET compatible devices) | 31 |
| 14.2 MIMO88SG, MIMO1212SG, MIMO88SG CONFERENCE & MIMO1212SG CONFERENCE SERIES SPECIFIC ERROR CODES | 31 |

1. IMPORTANT REMARK



WARNING: SHOCK HAZARD - DO NOT OPEN
AVIS: RISQUE DE CHOC ÉLECTRIQUE - NE PAS OUVRIR



The lightning flash with arrowhead symbol, within an equilateral triangle, is intended to alert the user to the presence of uninsulated “dangerous voltage” within the product’s enclosure that may be of sufficient magnitude to constitute a risk of electric shock to persons.



The exclamation point within an equilateral triangle is intended to alert the user to the presence of important operating and maintenance (servicing) instructions in the literature accompanying the appliance.

WARNING (If applicable): The terminals marked with symbol of “” may be of sufficient magnitude to constitute a risk of electric shock. The external wiring connected to the terminals requires installation by an instructed person or the use of ready-made leads or cords.

WARNING: To prevent fire or shock hazard, do not expose this equipment to rain or moisture.

WARNING: An apparatus with Class I construction shall be connected to a mains socket-outlet with a protective earthing connection.

2. IMPORTANT SAFETY INSTRUCTIONS

1. Read these instructions.
2. Keep these instructions.
3. Heed all warnings.
4. Follow all instructions.
5. Do not use this apparatus near water.
6. Clean only with dry cloth.
7. Do not block any ventilation openings. Install in accordance with the manufacturer’s instructions.
8. Do not install near any heat sources such as radiators, heat registers, stoves, or other apparatus (including amplifiers) that produce heat.

9. Do not defeat the safety purpose of the polarized or grounding type plug. A polarized plug has two blades with one wider than the other. A grounding type plug has two blades and a third grounding prong. The wide blade or the third prong are provided for your safety. If the provided plug does not fit into your outlet, consult an electrician for replacement of the obsolete outlet.
10. Protect the power cord from being walked on or pinched particularly at the plugs, convenience receptacles, and at the point where they exit from the apparatus.
11. Only use attachments/accessories specified by the manufacturer.
12. Unplug the apparatus during lightning sorts or when unused for long periods of time.
13. Refer all servicing to qualified personnel. Servicing is required when the apparatus has been damaged in any way, such as power supply cord or plug is damaged, liquid has been spilled or objects have fallen into the apparatus, the apparatus has been exposed to rain or moisture, does not operate normally, or has been dropped.
14. Disconnecting from mains: When switching off the POWER switch, all the functions and light indicators of the unit will be stopped, but fully disconnecting the device from mains is done by unplugging the power cable from the mains input socket. For this reason, it always shall remain easily accessible.
15. Equipment is connected to a socket-outlet with earthing connection by means of a power cord.
16. The marking information is located at the bottom of the unit.
17. The apparatus shall not be exposed to dripping or splashing and that no objects filled with liquids, such as vases, shall be placed on apparatus.

NOTE: This equipment has been tested and found to comply with the limits for a Class A digital device, pursuant to part 15 of the FCC Rules. These limits are designed to provide reasonable protection against harmful interference when the equipment is operated in a commercial environment. This equipment generates, uses, and can radiate radio frequency energy and, if not installed and used in accordance with the instruction manual, may cause harmful interference to radio communications. Operation of this equipment in a residential area is likely to cause harmful interference in which case the user will be required to correct the interference at his own expense.



WARNING: This product must not be discarded, under any circumstance, as unsorted urban waste. Take to the nearest electrical and electronic waste treatment centre.

NEEC AUDIO BARCELONA, S.L. accepts no liability for any damage that may be caused to people, animal or objects due to failure to comply with the warnings above.

3. IMPORTANT NOTE

Thank you for choosing our Ecler **MIMO88SG / 1212SG Installation Digital Matrix!**

It is **VERY IMPORTANT** to carefully read this manual and to fully understand its contents before any connection in order to maximize your use and get the best performance from this equipment.

To ensure optimal operation of this device, we strongly recommend that its maintenance be carried out by our authorised Technical Services.

Ecler **MIMO88SG / 1212SG** comes with a **3-year warranty**.

4. INTRODUCTION

The MIMO SG is a series of fully programmable digital audio matrixes, with the following features:

- 8 (MIMO88SG) or 12 (MIMO1212SG) balanced MIC/LINE inputs (independent phantom power per input channel).
- 8 (MIMO88SG) or 12 (MIMO1212SG) balanced LINE outputs.
- 8 (MIMO88SG) or 12 (MIMO1212SG) GPI control ports (*General Purpose Input*).
- Programming and remote management via Ethernet using EclerNet Manager (or point to point, with a direct CAT5 cable, or from an Ethernet network).
- Remote control via UCP (User Control Panel) clients on Ethernet: simultaneous clients with customized control panel, such as WPNETTOUCH Ecler, Android®, iOS®, Windows®, etc.
- Remote control from third party external devices. (Crestron, AMX, Vity, Medialon, etc. Registered trademarks of their manufacturers). TP-NET protocol, via Ethernet or RS-232 ports.
- Remote control bus for WPNETTOUCH digital panels and MPAGE16 messaging consoles (*paging*).
- Configuration memory (*presets*) management.
- Scheduled events based on calendar.
- WPNET4KV and WPNET8K compatible control panels (using specific retro-compatible Firmware*).
- * For more information see [WPNET4KV](#) and [WPNET8K](#) user's manual.
- Extensive DSP available:
 - Routing matrix/mixer, from any input to any output with adjustable level for crossover points (independent mixes of different inputs for each output).
 - Mono or stereo channel processing.

- Level control, mute, vu-meters and phase adjustment for inputs and outputs.
- Internal signal generator (sine wave, pink noise, white noise, polarity test).
- Parametric EQ on inputs and outputs.
- Delay on inputs and outputs.
- Gate/compressor on input channels.
- Compressor/limiter on outputs.
- Input channel priority assignment (*ducking*).
- Virtual and physical messaging consoles (*paging*).
- Standard MIMO88SG / MIMO1212SG firmware version (for generic use) and alternative version, for conferencing applications (MIMO88SG / MIMO1212SG CONFERENCE version). Both firmware versions are compatible with the MIMO88SG / MIMO1212SG hardware which can be freely updated with anyone of them.

The MIMO SG programming is done with [EclerNet Manager](#). Please refer to EclerNet Manager Software manual at www.ecler.com for more information.

5. INSTALLATION

5.1. Location, assembly, ventilation

MIMO SG series has been especially designed to be installed in a standard 19" rack, taking up 1U.

It is very important not to enclose the MIMO SG or expose it to extreme temperatures as it generates heat. It's also necessary to promote the passage of fresh air through the ventilation holes of the chassis, leaving at least one rack unit off between each device and installed above and below it in the rack frame.

If the setup has several amplifiers in the same rack or in a closed cabinet with doors, it is highly recommended to supply them forced ventilation, installing fans at the upper and lower ends. This upward air flow will help to dissipate the heat generated inside.

5.2. Connection to an AC outlet and switching on

All models in the MIMO SG series operate under voltages between 90 and 264 V at 47 to 63 Hz. This device features an over dimensioned power supply that adapts to the mains voltage in any country of the world with no need to make any adjustments.

On the rear panel, there is a power switch for the unit next to the IEC power connector. On the front panel, a LED lights up when the unit is switched on.

The mains cables must not be near the shielded cables carrying the audio signal, as this could cause humming.

5.3. Signal input connections

The rear panel of a MIMO SG unit offers 8 (MIMO88SG) or 12 (MIMO1212SG) balanced analogue signal inputs, "IN", accepting both line and microphone level signals. Input signal type selection and management are carried out from EclerNet Manager application. Please refer to EclerNet Manager Software manual at www.ecler.com for more information.

Signal input connectors are 3 position screw terminal block. The wiring is:

- Hot or direct signal > Terminal +
- Cold or inverted signal > Terminal -
- Ground > Terminal ⊥

For unbalanced connection short-circuit pin ⊥ to pin -.

5.4. Audio Output Connections

The rear panel of a MIMO SG offers 8 (MIMO88SG) or 12 (MIMO1212SG) analogue signal outputs "OUT", all balanced and accepting line level signals.

Signal output connectors are 3 position screw terminal block. The wiring is:

- Hot or direct signal > Terminal +
- Cold or inverted signal > Terminal -
- Ground > Terminal ⊥

For UNBALANCED connections, leave the – terminal unconnected.

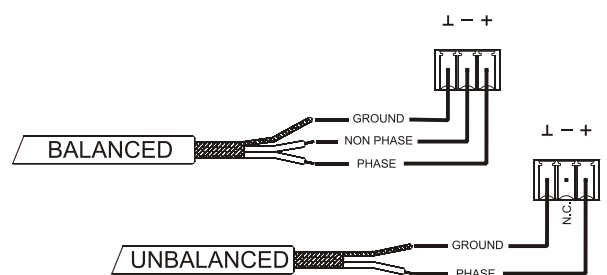

5.5. ETHERNET port for programming and control

An RJ45 type connector allows connecting the equipment to an Ethernet network:

- Management from EclerNet Manager application. Please refer to EclerNet Manager Software manual at www.ecler.com for more information.
- Possibility of direct connection (point to point) between a computer and a MIMO SG unit.
- Connection to third party other devices. (Crestron, AMX, Vity, Medialon, etc. Registered trademarks of their manufacturers). Protocol used: Ecler TP-NET. [See the TP-NET protocol manual](#) for more information.
- Connection to WPNETTOUCH units (remote control of an entire network of EclerNet devices through custom graphic panels).

5.5.1 Factory Preset Network settings

The factory default network settings for EclerNet Manager compatible devices are as follows:

- IP: 192.168.0.100
- Mask: 255.255.255.0
- Gate: 192.168.0.1
- UDP Port: 2210

5.6. REMOTE port for digital remote controls

The REMOTE port allows the connection of digital remote-control devices, such as the WPNETTOUCH wall panel or the MPAGE16 paging console. The REMOTE port is connected to the digital control bus the remote devices are daisy-chained to, the last one being loaded with a 120 Ω termination resistor between CAN HIGH and CAN LOW.

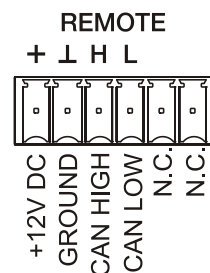

Refer to the remote device documentation (WPNETTOUCH, MPAGE16, etc) for more information about your connection and controls.

Please refer to EclerNet Manager Software manual at www.ecler.com for more information about programming a MIMO SG to manage the remote devices that are connected to the REMOTE port.

5.7. GPI Remote Control Ports

The rear panel of the MIMO SG offers 8 (MIMO88SG) or 12 (MIMO1212SG) GPI inputs for 0-10 VDC continuous control voltage. Each of these inputs can be connected to an external physical device (potentiometer, contact closure, continuously variable voltage 0-10V DC, etc.) and assigned to a MIMO SG function, as for example:

- Input, output channel or matrix crosspoint volume remote control by means of a WPaVOL physical knob or an Ecler WP Series' WPVOL-IR remote control
- MUTE or SOLO activation/deactivation by means of a switch or contact closure
- Recalling a *preset* with a push button or contact closure

GPI connectors are screw terminal blocks with three-contacts. The wiring is as follows:

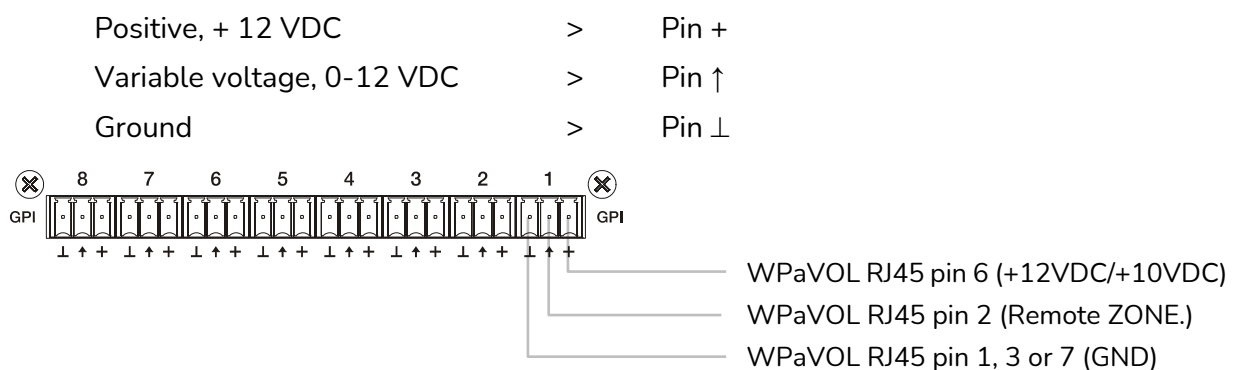

Jumpers position: ALOG / LIN → **LIN position**
 +12 / +10 → **+12 position**

WPaVOL connection to MIMO serial GPI ports

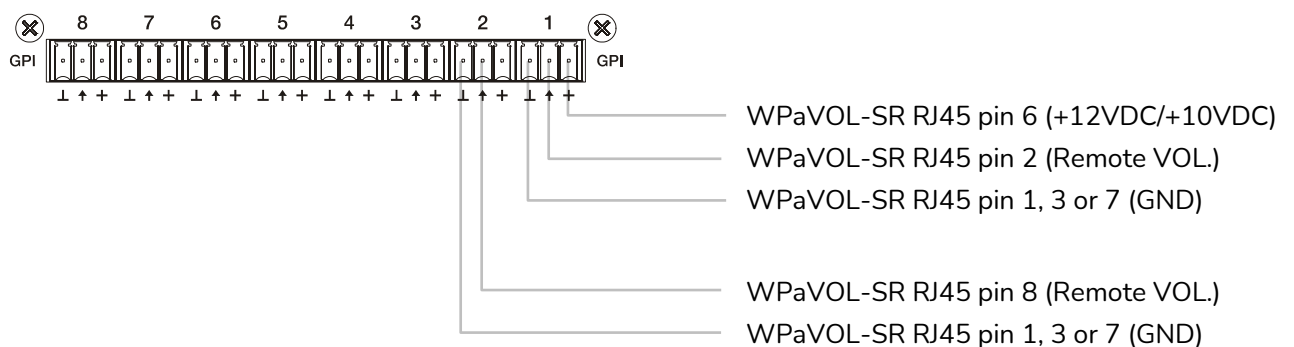

Jumpers position: ALOG / LIN → **LIN position**
 +12 / +10 → **+12 position**

WPaVOL-SR connection to MIMO serial GPI ports

Connecting cables can be up to 500 meters with a minimum section of 0.5 mm².

Consult your ECLER dealer or www.ecler.com about the WP series remote control wall panels and other accessories available for connection to the GPI port.

5.8. Remote control RS-232 Port

The built-in RS-232 port in the rear panel allows an external device to communicate with a MIMO SG unit via serial connection. Said connection uses the TP-NET protocol syntax so to enable the external device to obtain the value of any of the parameters of the MIMO SG unit (by "GET" commands) and/or modify said values ("SET" commands). [See the TP-NET protocol manual](#) for more information.

The serial connection should comply with the following specifications:

- Baud rate: 57600 (fixed, no auto negotiation)
- Data bits: 8
- Parity: None
- Stop bits: 1
- Flow control: None

| WIRING RS232 – DB9 | |
|--------------------|--------------------|
| RS232 | DB9 |
| Tx | Pin 2 (RxD) |
| Rx | Pin 3 (TxD) |
| Gnd | Pin 5 (Signal Gnd) |

5.9. Front panel controls and LED indicators

The following elements are available on the MIMO SG series front panel:

- **Input LED indicators:** indicate the presence of audio signal at the unit's input, and its intensity level (green, amber and red indicate in this order the increased intensity level)
- **Output LED indicators:** indicate the presence of audio signal at the unit's output, and its intensity level (green, amber and red indicate in this order the increased intensity level)
- **Status LED indicators (STATUS):**
 - **DATA:** Off: there is no connection to EclerNet Manager even if connected to Ethernet. On: connected to EclerNet Manager or to other third party application via TP-NET protocol. Flashing: data traffic with EclerNet Manager or another application.
 - **POWER:** Illuminates when the unit is in operation. It flashes if there is an error in the unit or if firmware is not correct. It also flashes when you update firmware

6. CLEANING

The front panel should not be cleaned with dissolvent or abrasive substances because silk-printing could be damaged. To clean it, use a soft cloth slightly wet with water and neutral liquid soap; dry it with a clean cloth. Be careful that water never gets into the unit through the holes of the front panel.

7. FUNCTION LIST

1. Input signal indicators, INPUTS
2. Output signal indicators, OUTPUTS
3. Data traffic indicator, DATA
4. Power on indicator, POWER
5. Signal output screw terminal, OUT
6. Signal input screw terminal, IN
7. RJ-45 connector, ETHERNET
8. Screw terminals for digital remote control, REMOTE
9. Screw-assembled remote-control terminals via the TP-NET, RS-232 protocol
10. Screw terminals for continuous voltage control, GPI
11. Mains socket
12. Fuse holder
13. Power switch

8. FUNCTION DIAGRAMS

8.1 MIMO88SG

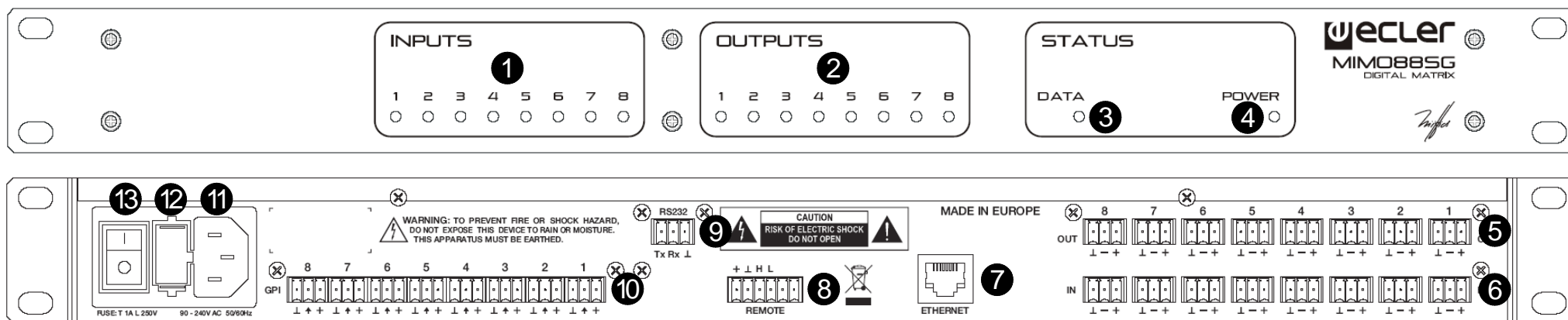

8.2. MIMO1212SG

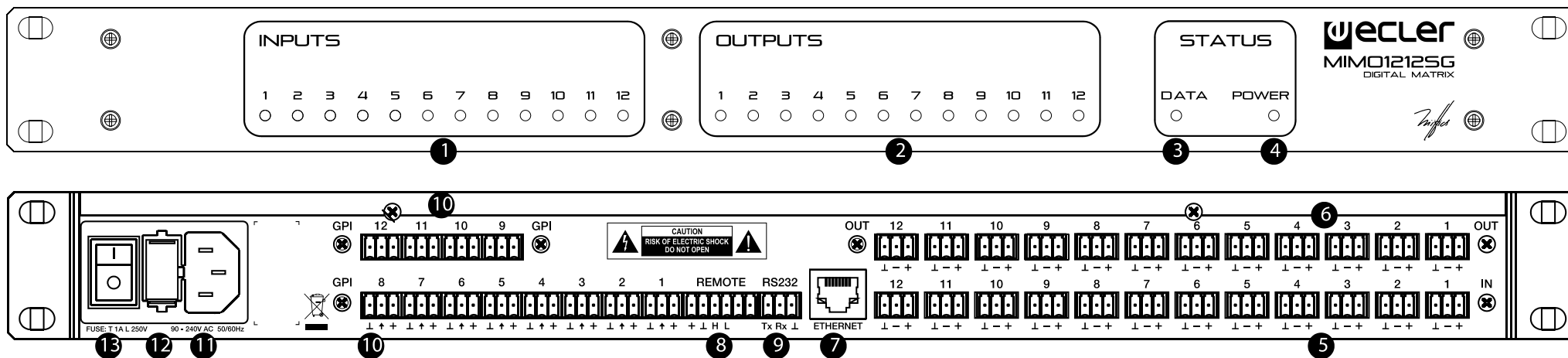

9. TECHNICAL CHARACTERISTICS

9.1. MIMO88SG

| DSP | |
|---------------------------------------|---|
| DSP | 2x 32/64bit |
| Sampling Rate | 48kHz |
| Latency IN to OUT | <2.9ms |
| Converters | |
| Resolution | 24bit AKM |
| Dynamic Range | AD:110dB, DA: 115dB |
| Analogue | |
| x8 Input/Output | Terminal block (Symmetrical) |
| Analogue Input headroom | +27dBV = +30dBu |
| Max. output level | +18dBV = +21dBu |
| Input sensitivity @ 0dBV out | From -50dBV to +10dBV in 0.5dB step |
| Input Impedance | Balanced, >4kΩ |
| Phantom power | +42VDC, 5mA max software switched |
| Frequency response (-3dB) | 5Hz to 24kHz |
| Flatness | better than ±0.1dB |
| THD+Noise @ 1kHz, 0dBV input (line) | <0.004% |
| THD+Noise @ 1kHz, -40dBV input (mic.) | <0.008% |
| Output Noise floor FFT (20Hz - 20kHz) | better than 115dB |
| Interchannel crosstalk (20Hz - 20kHz) | better than 90dB (100dB typ.) |
| Channel Leakage (20Hz - 20kHz) | better than 100dB (115dB typ.) |
| CMRR 20Hz- 20kHz | 65dB typ. |
| Processing | |
| Input Level (x8) | Range: from Off to 0 dB Mute: Yes Signal Polarity reverse: Yes Metering: VU+clip pre & post fader |
| Output Level (x8) | Range: from Off to 0 dB Mute: Yes Solo: Yes Signal Polarity reverse: Yes Metering: VU+clip pre & post fader |
| Output Gain | Range: from 0 to +6 dB |
| Input Delay (x8) | from 0 to 1000 ms Units: sec/ms/m/cm |
| Output Delay (x8) | from 0 to 1000 ms Units: sec/ms/m/cm. |

| | |
|--|--|
| Parametric Eq. Types (4 max per input) (6 max per input) | Bypass / On-Off all channels Param Eq. Freq: 20Hz-20kHz; Gain: -60/+12 dB; Q: 0.3 to 200 Low & High Shelf 6/12 dB/oct Low & High Pass 6/12 dB/oct All Pass 1/2 order |
| High & Low pass output Crossover filters (x8) | Bypass On-Off Butterworth in 6/12/18/24 dB/oct Bessel in 12/18/24 dB/oct Linkwitz-Riley in 12/24 dB/oct |
| Input Noise Gate (x8) | Bypass On-Off Threshold: from -80 dBV to +18 dBV Depth: 0 dB to 80 dB Attack time: from 0,1 ms. to 500 ms. Hold time: from 10 ms. to 3000 ms. Release time: from 10 ms. to 1000 ms. |
| Input Compressor / Limiter (x8) | Bypass On-Off Threshold: from -36 dBV to +18 dBV Ratio: 1:1 to inf:1 (limiter) Knee: hard / soft Attack time: from 0,1 ms. to 500 ms. Release time: from 10 ms. to 1000 ms. Make up gain: from 0 to +10 dB |
| Input Frequency Shifter (x4) (Feedback Loop Reducer) Output Limiter (x8) | Available on IN1 to IN4. ON / OFF function Bypass On-Off Threshold: from -36 dBV to +18 dBV Attack time: from 0,1 ms. to 500 ms. Release time: from 10 ms. to 1000 ms. |
| Built in Signal Generator | Sine: from 20 Hz to 20 kHz Polarity: from 20 Hz to 20 kHz White noise Pink noise |
| Stereo Linking | Adjacent input / output channels Linked processing Matrix routing linked |
| Mix Matrix | Size: 8x8 Vol: Input, Output, Crosspoint Mute: Set/Clear individual, row, column, all Input /output Mono/stereo selector Meter: Input /output VU and clip |
| Pager (x3) | Input: IN1 to IN8 Priorities: 3 (1 max, 3 min) Depth: 0 dB to 80 dB Attack time: from 5 ms. to 2000 ms. Release time: from 50 ms. to 3000 ms. Chime Source: None, Melody 1, Melody 2 Chime Volume: from -12 dB to 0 dB |
| Mechanical | |
| Dimensions (WxHxD) | 482.6x44x266.5mm |
| Weight | 3.5kg |

| Supply | |
|-------------------------------------|---|
| Mains | 90-264VCA 47-63Hz |
| Power consumption | 45VA |
| Miscellaneous | |
| Management Connectivity | Ethernet Base-Tx 10/100Mb Auto X-Over CAT5 up to 100m |
| Remote Bus | Over twisted pairs; up to 1km (see specific specs.) |
| GPI | 8, from 0 to 10VDC or TTL level |
| Aux. Power Supply for Remotes & GPI | +12VDC, 1.2A. max. (short circuit protected) |
| Time and date retention (battery) | 100 hours approx. (ambient temperature dependant) |
| RTC accuracy | ±1 minute / month |
| Software | |
| EclerNet Manager | From v3.03r4 version |

9.2. MIMO1212SG

| DSP | |
|---------------------------------------|--|
| DSP | 2x 32/64bit |
| Sampling Rate | 48kHz |
| Latency IN to OUT | <3.2ms |
| Converters | |
| Resolution | 24bit AKM |
| Dynamic Range | AD:110dB, DA: 115dB |
| Analogue | |
| 12 Input/Output | Terminal block (Symmetrical) |
| Analogue Input headroom | +27dBV = +30dBu |
| Max. output level | +18dBV = +21dBu |
| Input sensitivity @ 0dBV out | From -50dBV to +10dBV in 0.5dB step |
| Input Impedance | Balanced, >4kΩ |
| Phantom power | +42VDC, 5mA max. software switched |
| Frequency response (-3dB) | 5Hz to 24kHz |
| Flatness | better than ±0.1dB |
| THD+Noise @ 1kHz, 0dBV input (line) | <0.004% |
| THD+Noise @ 1kHz, -40dBV input (mic.) | <0.008% |
| Output Noise floor FFT (20Hz - 20kHz) | better than 115dB |
| Interchannel crosstalk (20Hz - 20kHz) | better than 90dB (100dB typ.) |
| Channel Leakage (20Hz - 20kHz) | better than 100dB (115dB typ.) |
| CMRR 20Hz- 20kHz | 65dB typ. |
| Processing | |
| Input Level (x12) | Range: from Off to 0 dB Mute: Yes Signal Polarity reverse: Yes Metering: VU + clip pre & post fader |

| | |
|--|---|
| Output Level (x12) | <p>Range: from Off to 0 dB</p> <p>Mute: Yes</p> <p>Solo: Yes</p> <p>Signal Polarity reverse: Yes</p> <p>Metering: VU + clip pre & post fader</p> |
| Output Gain (x12) | Range: from 0 to +6 dB |
| Input Delay (x12) | <p>from 0 to 1000 ms.</p> <p>Units: sec/ms/m/cm.</p> |
| Output Delay (x12) | <p>from 0 to 1000 ms.</p> <p>Units: sec/ms/m/cm.</p> |
| Parametric Eq. Types (4 max per input) (6 max per input) | <p>Bypass / On-Off all channels</p> <p>Param Eq. Freq: 20Hz-20kHz; Gain: -60/+12 dB; Q: 0.3 to 200</p> <p>Low & High Shelf 6/12 dB/oct</p> <p>Low & High Pass 6/12 dB/oct</p> <p>All Pass 1/2 order</p> |
| High & Low pass output Crossover filters (x12) | <p>Bypass On-Off</p> <p>Butterworth in 6/12/18/24 dB/oct</p> <p>Bessel in 12/18/24 dB/oct</p> <p>Linkwitz-Riley in 12/24 dB/oct</p> |
| Input Noise Gate (x12) | <p>Bypass On-Off</p> <p>Threshold: from -80 dBV to +18 dBV</p> <p>Depth: 0 dB to 80 dB</p> <p>Attack time: from 0,1 ms. to 500 ms.</p> <p>Hold time: from 10 ms. to 3000 ms.</p> <p>Release time: from 10 ms. to 1000 ms.</p> |
| Input Compressor / Limiter (x12) | <p>Bypass On-Off</p> <p>Threshold: from -36 dBV to +18 dBV</p> <p>Ratio: 1:1 to inf:1 (limiter)</p> <p>Knee: hard / soft</p> <p>Attack time: from 0,1 ms. to 500 ms.</p> <p>Release time: from 10 ms. to 1000 ms.</p> <p>Make up gain: from 0 to +10 dB</p> |
| Input Frequency Shifter (x4) (Feedback Loop Reducer) | Available on IN1 to IN4. ON / OFF function |
| Output Limiter (x12) | <p>Bypass On-Off</p> <p>Threshold: from -36 dBV to +18 dBV</p> <p>Attack time: from 0,1 ms. to 500 ms.</p> <p>Release time: from 10 ms. to 1000 ms.</p> |
| Built in Signal Generator | <p>Sine: from 20 Hz to 20 kHz</p> <p>Polarity: from 20 Hz to 20 kHz</p> <p>White noise</p> <p>Pink noise</p> |
| Stereo Linking | <p>Adjacent input / output channels</p> <p>Linked processing</p> <p>Matrix routing linked</p> |
| Mix Matrix | <p>Size: 12x12</p> <p>Vol: Input, Output, Crosspoint</p> <p>Mute: Set/Clear individual, row, column, all</p> <p>Input/output Mono/stereo selector</p> <p>Meter: Input/output VU and clip</p> |

| | |
|-------------------------------------|---|
| Pager (x3) | Input: IN1 to IN12 Priorities: 3 (1 max, 3 min) Depth: 0 dB to 80 dB Attack time: from 5 ms. to 2000 ms. Release time: from 50 ms. to 3000 ms. Chime Source: None, Melody 1, Melody 2 Chime Volume: from -12 dB to 0 dB |
| Mechanical | |
| Dimensions (WxHxD) | 482.6x44x266.5mm |
| Weight | 3.2kg |
| Supply | |
| Mains | 90-264VCA 47-63Hz |
| Power consumption | 75VA |
| Miscellaneous | |
| Management Connectivity | Ethernet Base-Tx 10/100Mb Auto X-Over CAT5 up to 100m. |
| Remote Bus | Over twisted pairs; up to 1km (see specific specs.) |
| GPI | 12, from 0 to 10VDC or TTL level |
| Aux. Power Supply for Remotes & GPI | +12VDC, 0,6A. max. (short circuit protected) |
| Time and date retention (battery) | 100 hours aprox. (ambient temperature dependant) |
| RTC accuracy | ±1 minute / month |
| Software | |
| EclerNet Manager | From v3.03r4 version |

10. BLOCK DIAGRAMS

10.1. MIMO885G

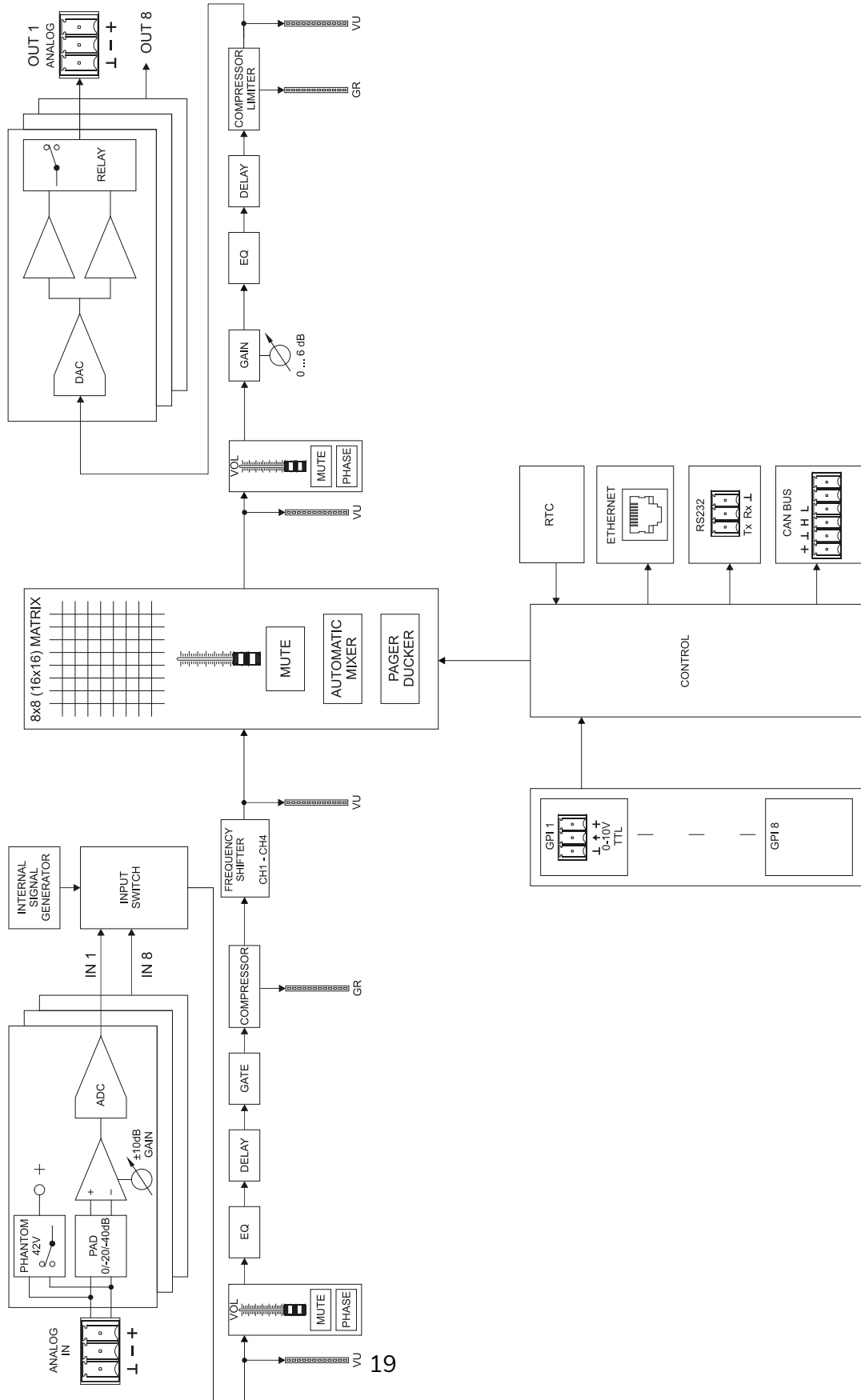

10.2. MIMO1212SG

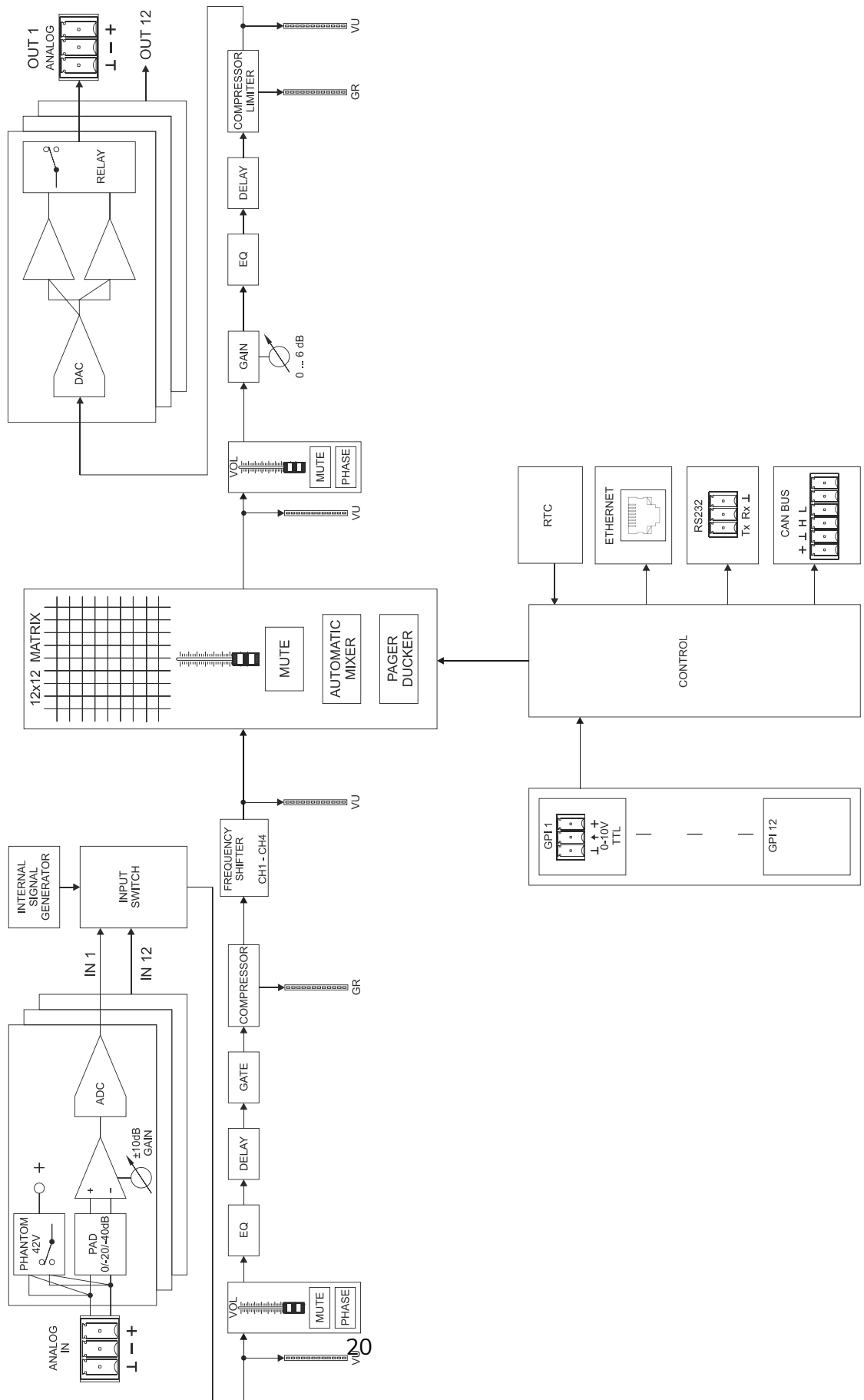

TP-NET PROTOCOL

SOFTWARE

Third-Party NET

USER MANUAL

11. TP-NET PROTOCOL INTRODUCTION

The TP-NET protocol lets a client device (control device) get and/or set the values of several parameters of the **EclerNet compatible devices** (MIMO and **MIMO SG series digital matrices**, DUO-NET PLAYER, NXA digital audio manager series, NZA amplifier series, NPA amplifier series, etc.), like volumes, mutes, alarms, etc. It's as well available for eMIMO1616 digital matrix, HUB series digital zoner, MIMO7272DN and MIMO4040CDN digital matrix.

The communication with these digital audio devices can be established using Ethernet and the UDP/IP transport protocol, always by means of the **5800** UDP port.

A second option for this communication is using the RS-232 interface that some of these compatible devices do also have (MIMO series, DUO-NET PLAYER, NXA series, etc.). In this case, the serial connection must fulfil the following specifications:

- Baud rate: **57600** (fixed, no autonegotiation) for all the devices, except for DUO-NET PLAYER, eMIMO1616, HUB series and MIMO4040CDN, which use **115200** baud rate)
- Data bits: 8
- Parity: None
- Stop bits: 1
- Flow control: None

In case the Ecler device has an Euroblock connector for the RS-232 interface, the serial cable wiring, from the device's connector to a standard DB9 serial interface connector, must be the following:

| WIRING RS232 – DB9 | |
|--------------------|--------------------|
| RS232 | DB9 |
| Tx | Pin 2 (RxD) |
| Rx | Pin 3 (TxD) |
| Gnd | Pin 5 (Signal Gnd) |

The protocol is simple and direct, making it easy to read, write and modify the generated code. It is based on messages with no begin and end delimiter: each message is self-delimited by the UDP packet size, which is defined with a maximum of **80 characters**. All the messages must be written in capital letters.

To let some control systems (like CRESTRON®, EXTRON®, AMX®, RTI®, VITY®, MEDIALON®, etc.) process the messages more easily, the EclerNet device adds the character **LF (0x0A)** to the end of each message. This way the client can buffer the messages to process them, if it's required. The EclerNet device can also handle several messages received in a single message packet by using the **LF** delimiter.

The available messages are built with one or more fields separated with blank spaces (= blank space):

<TYPE> [PARAM1] [PARAM2] [PARAM3] [PARAM4][LF]

The first field (**TYPE**) defines the **message type** and then, the required parameters for it (each kind of message requires a given number of parameters). The field **TYPE** can have these values:

- **SYSTEM**
- **GET**
- **SET**
- **INC**
- **DEC**
- **SUBSCRIBE**
- **UNSUBSCRIBE**
- **DATA**
- **ERROR**

At the end of this document you'll find all the available messages and their parameters for each model of the EclerNet compatible devices.

The **SYSTEM**, **GET**, **SET**, **INC**, **DEC**, **SUBSCRIBE** & **UNSUBSCRIBE** messages can be sent from the client to the EclerNet device. The **DATA** & **ERROR** messages can be sent from the device to the client. The only exception is the **SYSTEM PING** message, that is a **SYSTEM** type message that is sent from the EclerNet device when the initial message from the client to the device was **SYSTEM CONNECT PINGPONG**.

The communication (using UDP or RS-232) starts when a client sends the message **SYSTEM CONNECT** to the EclerNet device. As far as the UDP communication requires no connection (unlike the TCP), the EclerNet device stores this client's IP address, and then uses it as the destination IP address for the messages that it generates (**DATA** & **ERROR**). After receiving the **SYSTEM CONNECT** message, the device dumps its entire configuration using several consecutive **DATA** messages.

The communication can be terminated by two methods:

- **Manually:** when the client sends the **SYSTEM DISCONNECT** message, cancelling all the subscriptions and stopping the **DATA** & **ERROR** messages
- **Automatically:** in case the initial message was **SYSTEM CONNECT PINGPONG** and the client didn't get any **SYSTEM PONG** message in a period longer than 10 seconds (presuming a communication breakdown).

The **SET** messages don't have an automatic acknowledgement with a **DATA** message sent from the EclerNet device after it has processed the **SET** command. The client must update the values itself and must send the needed **GET** message if it requires confirmation from the device.

NOTES:

- The numerical values are always integer numbers without +, -, comma or dot symbols.
- **[PINGPONG]** is an optional parameter used to configure the device-client communication with a periodical check, to see whether the client or the device have terminated it. When configured this way, the device sends a **SYSTEM PING** once per second, and the client must answer with a **SYSTEM PONG** message. If anyone doesn't get these messages along a 10 seconds period, the communication will be considered terminated
- **<Input Channel>** & **<Output Channel>** are numerical values that identify an input or output channel of the EclerNet device:
 - It can be within a [1..8] range for MIMO88SG units.
 - It can be within a [1..12] range for MIMO1212SG units.
- **<Preset Number>** is a numerical value that identifies one available Preset stored in the EclerNet device's memory.
- **<Level>**, **<Pre Vumeter Level>** y **<Post Vumeter Level>** are numerical values in the [0..100] range that define values in a scale equivalent to [-inf..0] dB.
- **<GPI>** & **<GPO>** are numerical values within the [1..8] range for the MIMO88 configured as 8x8 matrix masters (single units), and [1..16] for MIMO88 couples configured as 16x16 matrix masters. For the NXA series GPI values can be within the [1..4] or [1..6] range, depending on model. For the MIMO7272DN and MIMO4040CDN GPI and GPO values can be within [1..8].
- **<GPI Value>** is a numerical value within the [0..100] range that indicates the value of an analogue GPI input. For a digital input only 0 or 100 are the possible values.
- **<GPO Value>** is a numerical value within the [0..1] range: it can only be 0 or 1 (opened or closed GPO).
- **<Rate>** is a numerical value within the [1..10] range that sets the VU-meter refresh rate, or the number of times the vumeters' values are sent per second (by default = 3).
- **"<Device Name>"** is the device name inside double quotation marks, to allow for names with blank spaces.
- **<Error ID>** is a numerical value for an error code.
- **"<Error Description>"** is a text chain inside double quotation marks, containing an error description.
- **<Virtual Control>** is a numerical value that identifies a Virtual Control. It can be within a [1..64] range for MIMO88SG, MIMO88SGCONF, , MIMO1212SG and MIMO1212SGCONF models.

12. MIMO88SG / MIMO1212SG (SINGLE) DIGITAL MATRIX

IMPORTANT NOTE: The communication must be started with the client sending **the first message SYSTEM CONNECT** to the EclerNet device. Otherwise, the commands from the client to the EclerNet device will be ignored. See [TP-NET PROTOCOL INTRODUCTION chapter](#) for additional information.

| TYPE | PARAM1 | PARAM2 | PARAM3 | PARAM4 | DESCRIPTION |
|---------------|-------------------|------------------|------------------|--------|---|
| SYSTEM | CONNECT | [PINGPONG] | | | Saves the client IP address for responses and then dumps current device status (with DATA messages) |
| | DISCONNECT | | | | Cancel subscriptions and terminates communication |
| | SUBSCRIPTION_RATE | <Rate> | | | Alive message from device |
| | PING | | | | Alive message from device |
| | PONG | | | | Alive ACK message from client |
| GET | ALL | | | | Dumps current device status (with DATA messages) |
| | PRESET | | | | Gets the current PRESET |
| | ILEVEL | <Input Channel> | | | Gets the current LEVEL of an Input Channel |
| | OLEVEL | <Output Channel> | | | Gets the current LEVEL of an Output Channel |
| | XLEVEL | <Input Channel> | <Output Channel> | | Gets the current LEVEL of a Matrix point |
| | IMUTE | <Input Channel> | | | Gets the current MUTE status of an Input Channel |
| | OMUTE | <Output Channel> | | | Gets the current MUTE status of an Output Channel |

| | | | | |
|-----------------|-------------------|------------------|--|---|
| XMUTE | <Input Channel> | <Output Channel> | | Gets the current MUTE status of a Matrix Point |
| IVU | <Input Channel> | | | Gets the VU-meter value of an Input Channel |
| OVU | <Output Channel> | | | Gets the VU-meter value of an Output Channel |
| GPI | <Input> | | | Gets the current value of a General Purpose Input |
| GPO | <Output> | | | Gets the current value of a General Purpose Output (not valid for MIMO88SG / MIMO1212SG) |
| INFO_NAME | | | | Gets the Device Name |
| INFO_MODEL | | | | Gets the Device Model |
| INFO_VERSION | | | | Gets the Firmware Version |
| INFO_MAC | | | | Gets the Device MAC address |
| VIRTUAL_CONTROL | <Virtual Control> | | | Gets the Virtual Control value |

| TYPE | PARAM1 | PARAM2 | PARAM3 | PARAM4 | DESCRIPTION |
|------|-----------------|-------------------|------------------|---------|--|
| SET | PRESET | <Preset Number> | | | Sets the current PRESET |
| | ILEVEL | <Input Channel> | <Level> | | Sets the current LEVEL of an Input Channel |
| | OLEVEL | <Output Channel> | <Level> | | Sets the current LEVEL of an Output Channel |
| | XLEVEL | <Input Channel> | <Output Channel> | <Level> | Sets the current LEVEL for a Matrix point |
| | IMUTE | <Input Channel> | YES/NO | | Sets the current MUTE status of an Input Channel |
| | OMUTE | <Output Channel> | YES/NO | | Sets the current MUTE status of an Output Channel |
| | XMUTE | <Input Channel> | <Output Channel> | YES/NO | Sets the current MUTE status for a Matrix Point |
| | GPO | <Output> | <GPO Value> | | Sets the current value for a General Purpose Output (not valid for MIMO88SG) |
| | VIRTUAL_CONTROL | <Virtual Control> | <Value> | | Sets the Virtual Control value (Value can range from 1 to 100) |
| INC | ILEVEL | <Input Channel > | <Value> | | Increases the current LEVEL of an Input Channel by Value (Value can range from ± 1 to ± 100) |
| | OLEVEL | <Output Channel> | <Value> | | Increases the current LEVEL of an Output Channel by Value (Value can range from ± 1 to ± 100) |
| | XLEVEL | <Input Channel> | <Output Channel> | <Value> | Increases the current LEVEL of a Matrix point by Value (Value can range from ± 1 to ± 100) |
| DEC | ILEVEL | <Input Channel > | <Value> | | Decreases the current LEVEL of an Input Channel by Value (Value can range from ± 1 to ± 100) |
| | OLEVEL | <Output Channel> | <Value> | | Decreases the current LEVEL of an Output Channel by Value (Value can range from ± 1 to ± 100) |

| | XLEVEL | <Input Channel> | <Output Channel> | <Value> | Decreases the current LEVEL of a Matrix point by Value (Value can range from ± 1 to ± 100) |
|--------------------|--------|------------------|------------------|---------|---|
| SUBSCRIBE | ALL | | | | Subscribes to all VU-meters |
| | IVU | <Input Channel> | | | Subscribes to an Input Channel VU-meter |
| | OVU | <Output Channel> | | | Subscribes to an Output Channel VU-meter |
| UNSUBSCRIBE | ALL | | | | Unsubscribe to all VU-meters |
| | IVU | <Input Channel> | | | Unsubscribe to an Input Channel VU-meter |
| | OVU | <Output Channel> | | | Unsubscribe to an Output Channel VU-meter |

Note: **INC** and **DEC** commands are replied with a **DATA** command from the device with the resulting LEVEL value, after it has been increased or decreased. When the **INC** or **DEC** command tries to adjust a LEVEL value beyond its minimum or maximum limits, no reply (**DATA** command) will be produced.

| TYPE | PARAM1 | PARAM2 | PARAM3 | PARAM4 | DESCRIPTION |
|--------------|----------------------|-----------------------|---------------------|------------------------------|--|
| DATA | PRESET | <Preset Number> | | | Shows the current PRESET |
| | ILEVEL | <Input Channel> | <Level> | | Shows the current LEVEL of an Input Channel |
| | OLEVEL | <Output Channel> | <Level> | | Shows the current LEVEL of an Output Channel |
| | XLEVEL | <Input Channel> | <Output Channel> | <Level> | Shows the current LEVEL for a Matrix point |
| | IMUTE | <Input Channel> | YES/NO | | Shows the current MUTE status of an Input Channel |
| | OMUTE | <Output Channel> | YES/NO | | Shows the current MUTE status of an Output Channel |
| | XMUTE | <Input Channel> | <Output Channel> | YES/NO | Shows the current MUTE status for a Matrix Point |
| | VIRTUAL_CONTROL | <Virtual Control> | <Value> | | Shows the Virtual Control value (Value can range from 1 to 100) |
| | IVU | <Input Channel> | <Pre Vumeter Level> | <Post Vumeter Level> | Shows the VU-meter value of an Input Channel |
| | OVU | <Output Channel> | <Pre Vumeter Level> | <Post Vumeter Level> | Shows the VU-meter value of an Output Channel |
| | GPI | <Input> | <GPI Value> | | Shows the current value of a General Purpose Input |
| | GPO | <Output> | <GPO Value> | | Shows the current value of a General Purpose Output. (not valid for MIMO88SG) |
| | INFO_NAME | "<Device Name>" | | | Shows the Device Name |
| | INFO_MODEL | <Device Model> | | | Shows the Device Model |
| INFO_VERSION | <Firmware Version> | | | Shows the Firmware Version | |
| INFO_MAC | <Device MAC address> | | | Shows the Device MAC address | |
| ERROR | <Error ID> | "<Error Description>" | | | Informs about an error |

13. MIMO88SG CONFERENCE DIGITAL MATRIX

IMPORTANT NOTE: The communication must be started with the client sending **the first message SYSTEM CONNECT** to the EclerNet device. Otherwise, the commands from the client to the EclerNet device will be ignored. See [TP-NET PROTOCOL INTRODUCTION](#) chapter for additional information.

This MIMO88SG CONFERENCE firmware version shares the same hardware with the standard MIMO88SG unit, just uploading the CONFERENCE firmware version to it, and shares as well the same TP-NET commands in the above table, adding to them these new ones:

| TYPE | PARAM1 | PARAM2 | PARAM3 | PARAM4 | DESCRIPTION |
|-------------|-----------|----------------------------|--------|--------|---|
| GET | GATE | | | | Gets the current status of the NOISE GATE for inputs 1 to 8 |
| | AUTOMIXER | | | | Gets the current status of the AUTOMIXER function for inputs 1 to 8 |
| SUBSCRIBE | GATE | | | | Subscribes to the status of the NOISE GATE for inputs 1 to 8 |
| | AUTOMIXER | | | | Subscribes to the status of the AUTOMIXER function for inputs 1 to 8 |
| UNSUBSCRIBE | GATE | | | | Unsubscribes to the status of the NOISE GATE for inputs 1 to 8 |
| | AUTOMIXER | | | | Unsubscribes to the status of the AUTOMIXER function for inputs 1 to 8 |
| DATA | GATE | s1 s2 s3 s4 s5 s6 s7 s8 | | | Shows the current NOISE GATE status (0 = open / 1 = closed) for the 8 inputs channels (s1 to s8, status of the gate for inputs 1 to 8) |
| | AUTOMIXER | s1 s2 s3 s4 s5 s6 s7 s8 | | | Shows the current status for input channels in the Automixer section (0 = disabled or bellow threshold in the automixer / 1 = enabled and beyond threshold, but queued, not in the automatic mix / 2 = enabled, beyond threshold and into the automatic mix) for the 8 inputs channels (s1 to s8, status of the automixer function for inputs 1 to 8) |

14. ERROR CODES FOR ECLERNET DEVICES

14.1. COMMON ERROR CODES (to all EclerNet - TP-NET compatible devices)

| ERROR ID | DESCRIPTION |
|----------|-----------------------------------|
| 0 | TPNET_ERROR_NONE = 0, |
| 1 | TPNET_ERROR_INVALID_FIELD_TYPE, |
| 2 | TPNET_ERROR_INVALID_FIELD_PARAM1, |
| 3 | TPNET_ERROR_INVALID_FIELD_PARAM2, |
| 4 | TPNET_ERROR_INVALID_FIELD_PARAM3, |
| 5 | TPNET_ERROR_INVALID_FIELD_PARAM4, |

14.2 MIMO88SG, MIMO1212SG, MIMO88SG CONFERENCE & MIMO1212SG CONFERENCE SERIES SPECIFIC ERROR CODES

| ERROR ID | DESCRIPTION |
|----------|--|
| 6 | UDP_ERROR_TIMEOUT_PONG, |
| 7 | UDP_ERROR_CONNECT_WHILE_CONNECTED, |
| 8 | UDP_ERROR_DISCONNECT_WHILE_UNCONNECTED, |
| 9 | UDP_ERROR_INVALID_CLIENT_IP, |
| 10 | UDP_ERROR_MESSAGE_TOO_LONG, |
| 11 | UDP_ERROR_UNSUPPORTED_MESSAGE, |
| 12 | UDP_ERROR_UNSUPPORTED_PRESET_NUMBER, |
| 13 | UDP_ERROR_UNSUPPORTED_INPUT_CHANNEL_NUMBER, |
| 14 | UDP_ERROR_UNSUPPORTED_OUTPUT_CHANNEL_NUMBER, |
| 15 | UDP_ERROR_UNSUPPORTED_GPI_NUMBER, |
| 16 | UDP_ERROR_INVALID_LEVEL_VALUE, |
| 17 | UDP_ERROR_INVALID_RATE_VALUE, |

All product characteristics are subject to variation due to production tolerances. **NEEC AUDIO BARCELONA S.L.** reserves the right to make changes or improvements in the design or manufacturing that may affect these product specifications.

For technical queries contact your supplier, distributor or complete the contact form on our website, in [Support / Technical requests](#).

Motors, 166-168 08038 Barcelona - Spain - (+34) 932238403 | information@ecler.com | www.ecler.com